

Transceiver Design for Wireless Energy Harvesting

Cooperative Networks



Shiyang Hu

Lancaster University

School of Computing and Communications,

Lancaster, UK.

A thesis submitted for the degree of

Doctor of Philosophy

2016

To my beloved ones, for their support and encouragement.

Acknowledgements

In my Ph.D. study at the Lancaster University, I was lucky to have the great opportunity to work with my supervisor Prof. Zhiguo Ding who introduced me to research the wireless energy harvesting. Without any doubt, I could not achieve my research project without his help. I want to express my sincere gratitude for his valuable guidance and continuous support.

I want to direct my special gratitude to my second supervisor Prof. Qiang Ni for his suggestions in my Ph.D. study. His broad knowledge helped me to overcome many difficulties.

My gratitude is also extended to the School of Computing and Communications for giving me the opportunity to have this memorable learning experience.

Finally, I would like to express my sincere gratitude to my parents who have always supported me. They were always there when I needed them. My parents deserve far more credit than I can give.

Declaration

I declare that this thesis is my work, and it has not been previously submitted, either by me or by anyone else, for a degree or diploma at any educational institute, school or university. To the best of my knowledge, this thesis does not contain any previously published work, except where another person's work used has been cited and included in the list of reference.

Abstract

In this thesis, the RF energy harvesting technique is studied in the cooperative wireless network, and different optimization studies are investigated. First, an energy-efficient optimization is considered in the cooperative system with the time switching relaying and power splitting relaying protocols. Then, a security issue in the cooperative network with energy harvesting is proposed, in which the optimization problem is designed to maximize the secrecy rate. We also consider the application of energy harvesting in the full-duplex relaying network with a self-energy recycling protocol. Finally, the energy harvesting is studied in the full-duplex cooperative cognitive radio network. The system performance of all studies is verified in the thesis with MATLAB simulation results.

Contents

List of Figures	x
List of Tables	xiii
List of Acronyms	xiv
List of Symbols	xvi

Contents

1. Introduction.....	1
1.1 An Overview of Wireless Energy Harvesting	1
1.2 Contributions.....	5
1.3 Publications Arising From This Research.....	6
1.4 Outline of the Thesis	8
2. Background.....	9
2.1 Architecture of Wireless Energy Harvesting Network.....	9
2.2 Wireless Energy Harvesting Technique	12
2.3 Applications of Wireless Energy Harvesting	15

2.4 Wireless Information and Power Transfer	16
2.4.1 Separated Structure	18
2.4.2 Time Switching and Power Splitting	20
2.4.3 Integrated Structure.....	23
2.5 Literature Review for SWIPT	25
2.5.1 Energy Harvesting Protocols	25
2.5.2 Energy Harvesting for Multi-Antenna Network	30
2.5.3 Cooperative Relaying Network.....	38
2.6 Chapter Summary	45
3. Energy-Efficient Optimization in Cooperative Networks with Wireless Information and Power Transfer	46
3.1 Introduction.....	46
3.2 System Model	47
3.3 Energy-Efficient Optimization based on Time Switching Relaying Protocol ...	49
3.3.1 Time Switching Relaying Protocol	49
3.3.2 System Transmission Model	50

3.3.3 Problem Formulation	53
3.4 Energy-Efficient Optimization based on Power Splitting Relaying Protocol....	55
3.4.1 Power Splitting Relaying Protocol.....	55
3.4.2 System Transmission Model	56
3.4.3 Problem Formulation	58
3.5 Solution of Formulated Optimization Problems	59
3.6 Numerical Results	66
3.7 Chapter Summary	73
4. Secure Communication in Cooperative Networks with Wireless Information and Power Transfer	74
4.1 Introduction.....	74
4.2 System Model	76
4.3 Secrecy Rate Maximization based on Power Splitting Relaying Protocol	78
4.3.1 System Transmission Model and Problem Statement.....	78
4.3.2 The Optimal Solution.....	83
4.4 Secrecy Rate Maximization based on Time Switching Relaying Protocol.....	89

4.4.1 System Transmission Model and Problem Statement.....	89
4.4.2. The Optimal Solution.....	92
4.5 Numerical Results	95
4.6 Chapter Summary	100
5. Beamforming Optimization in Energy Harvesting Cooperative Full-Duplex Networks with Self-Energy Recycling Protocol.....	101
5.1 Introduction.....	101
5.2 System Model	103
5.3 Beamforming with Self-Energy Recycling Relay	105
5.3.1 Relay Protocol and Transmission Model.....	105
5.3.2 Problem Formulation and Beamforming Design	109
5.4 Beamforming with Time Switching Relaying Protocol.....	112
5.4.1 Time Switching Relaying Protocol and Transmission Model.....	113
5.4.2 Problem Formulation and Beamforming Design	115
5.5 Numerical Results	119
5.6 Chapter Summary	125

6. Beamforming Optimization for Full-Duplex Cooperative Cognitive Radio Networks with Self-Energy Recycling Protocol	126
6.1 Introduction.....	126
6.2 System Model	128
6.3 Beamforming with Self-Energy Recycling Protocol	130
6.3.1 Self-Energy Recycling Protocol and Transmission Model	130
6.3.2 Problem Formulation and Beamforming Design	134
6.4 Numerical Results	138
6.5 Chapter Summary	144
7. Conclusion and Future Works.....	145
7.1 Conclusion	145
7.2 Future Works	148
Appendix.....	150
References.....	152

List of Figures

2.1 General architecture of the RF energy harvesting network.....	10
2.2 The architecture of the RF energy harvesting network node.....	11
2.3 The architecture of the RF energy receiver.....	12
2.4 Separated receiver structure.....	19
2.5 Time switching structure.....	20
2.6 Power splitting structure.....	23
2.7 Integrated receiver structure.....	24
2.8 System model for multi-antenna SWIPT network.....	32
2.9 The co-channel interference SWIPT network.....	34
3.1 System model for the relay node assisting communication between the source node and the destination node.....	49
3.2 The performance of proposed algorithm with the time switching relaying protocol and the power splitting relaying protocol.....	69
3.3 Energy efficiency optimization for the time switching relaying protocol with	

different parameters.....	70
3.4 Energy efficiency optimization for the power splitting relaying protocol with different parameters.....	71
3.5 Energy efficiency for energy harvesting protocols versus distances.....	72
4.1 System model for energy harvesting cooperative network with one source-destination pair and one eavesdropper.....	77
4.2 Secrecy rate versus transmitted power at the source node for the proposed schemes with energy harvesting protocols.....	96
4.3 Secrecy rate versus transmitted power at the source node for the power splitting relaying protocol with different choices of system parameters.....	98
4.4 Secrecy rate versus transmitted power at the source node for the time switching relaying protocol with different choices of system parameters.....	99
5.1 System model for energy harvesting cooperative network with self-energy recycling protocol.....	104
5.2 Achievable rate versus transmitted power at the source node for different energy harvesting protocols.....	120

5.3 Achievable rate versus transmitted power at the source node for the self-energy recycling relaying protocol with different loop channel path loss.....	122
5.4 Performance comparison of the self-energy recycling protocol with different numbers of antenna.....	123
5.5 Performance comparison of the self-energy recycling protocol with different numbers of distances.....	124
6.1 System model for full-duplex cooperative cognitive radio network with self-energy recycling protocol.....	130
6.2 Achievable SU's rate versus transmitted power at the PT for different energy harvesting protocols.....	140
6.3 Achievable SU's rate versus transmitted power at the PT for self-energy recycling relaying protocol with different numbers of antenna.....	142
6.4 Achievable SU's rate versus transmitted power at the PT for self-energy recycling relaying protocol with different distances.....	143

List of Tables

3.1 Energy-Efficient Optimization Iteration Algorithm.....	65
4.1 SBP rank reduction procedure.....	87

List of Acronyms

1-D	One-Dimensional
AC	Alternating Current
AF	Amplify-and-Forward
AWGN	Additive White Gaussian Noise
CSI	Channel State Information
DC	Direct Current
DF	Decode-and-Forward
FCC	Federal Communications Commission
ISM	Industrial Scientific Medical
KKT	Karush-Kuhn-Tucker
MIMO	Multiple-input Multiple-output
MISO	Multiple-input Single-output
MRC	Maximum Ratio Combining
OFDM	Orthogonal Frequency-Division Multiplexing

PT	Primary Transmitter
PU	Primary User
QoS	Quality-of-Service
RF	Radio Frequency
RFID	Radio Frequency Identification
SBP	Shapiro-Barvinok-Pataki
SDP	Semidefinite Programming
SIMO	Single-input Multiple-output
SINR	Signal-to-Interference-plus-Noise Ratio
SISO	Single-input Single-output
SNR	Signal-to-Noise Ratio
ST	Secondary Transmitter
SU	Secondary User
SWIPT	Simultaneous Wireless Information and Power Transfer
TDMA	Time Division Multiple Access
WSN	Wireless Sensor Network

List of Symbols

$(\cdot)^*$	Conjugate
$(\cdot)^H$	Conjugate and transpose
$(\cdot)^T$	Transpose
$ x ^+$	$\max\{0, x\}$
$\ \mathbf{x}\ ^2$	Frobenius norm
$\mathbb{C}^{M \times N}$	Space of $M \times N$ matrices with complex entries
A_e	Antenna effective area
G_R	Received antenna gain
G_T	Transmitted antenna gain
N_r	Number of receiving antenna
N_t	Number of transmission antenna
$ x $	Absolution value of a scalar
\mathbf{H}_r	Channel matrix of loop channel
\mathbf{I}_N	$N \times N$ identity matrix

w_r	Receiving beamforming vector
w_s	Cognitive beamforming vector
w_t	Transmission beamforming vector
\otimes	Kronecker operator
$\cos\phi$	Polarization loss factor
$\mathcal{E}(\cdot)$	Expectation over random variables
h	Channel gain
E	Harvested energy
T	Block time
$Tr(\cdot)$	Trace of a matrix
W	Bandwidth
s	Normalized transmitted signal
vec	Matrix vectorization
W	Precoding matrix
h	Channel vector
α	Time switching coefficient

η	Energy conversion efficiency coefficient
ρ	Power splitting coefficient
σ	Standard Deviation of Noise

Chapter 1

Introduction

1.1 An Overview of Wireless Energy Harvesting

Since the 1890s, Nikola Tesla proposed that the energy can be transmitted over the wireless channel. This idea was initially assumed to transfer wireless power in a long distance and to support high power electronic devices. However, there were some practical issues to achieve the wireless power transfer at that time. The major difficulty was the low energy efficiency, which means that the energy harvester could only collect small power despite the large power transmitted at the source of energy. Also, at that time, the circuit required more power to supply. The concern regarding health was also another reason. Therefore, the wireless power transfer did not draw much attention until recently.

There is an emerging technique to convert the RF signal into energy, which is the

RF energy harvesting technology [1]. This method can be used for wirelessly powering the communication network. In the present-day wireless communication network, due to the development of the silicon technology reducing the power requirement for electronic devices, there is a rising number of low-powered devices used, which can be wirelessly powered by the RF energy harvesting technique. In [2], a low-powered temperature meter was wirelessly charged by RF signals transmitted from the TV station. Cellular networks and WSNs have been widely applied, in which the battery conventionally powers the wireless node. In the energy-constrained network, the battery usage has a threshold, which leads to that the communication performance is confined. Under some circumstances, replacing batteries is costly and inconvenient, such as the power supply in a large-scale WSN, or even impossible in some environment, such as embedded medical devices and toxic surroundings. However, for the RF energy harvesting network, the communication node can be wirelessly powered by the radio environment. Therefore, many energy-constrained networks can benefit from the RF energy harvesting technique, such as the wireless sensor network and the embedded body system. In [3], the authors proposed a sensor

network wirelessly powered by the radio environment. In [4], the authors presented a wireless RF-powered body network for the medical purpose. With the increasing number of the RF energy harvesting application, the RF energy harvesting technique also attracts the interest from the industry. The international standard related to the RF energy harvesting was established by the Wireless Power Consortium. Some experiments for applying RF energy harvesting were held [5]. The RF energy harvesting can be used in wireless devices for harvesting energy from the radio environment and can also be used in power transfer from energy sources to wireless devices.

The radio signal with the frequency range from 3 KHz to 300 GHz is used in RF energy harvesting. The RF power transfer is implemented by modulating signals on the amplitude and phase of RF waves. Due to that the RF power transfer can be achieved in the long-distance case and the broadcasting property of microwave, the RF energy harvesting technique is suitable for wirelessly charging a group of communication nodes deployed in a wide area, such as RFID application and sensors. The strength of RF energy-carrying signal is attenuated by 20 dB per decade of the

distance. In [1], The authors experimented that the RF energy harvesting technique has a decent, efficient performance in its effective range. In [6], the authors proposed that the MIMO technique can improve the RF energy harvesting efficiency.

The RF energy harvesting can be used in wireless communication networks to improve the system performance. With this new technique, an enormous amount of studies regarding the energy harvesting used in the traditional communication system have arisen. In particular, the beamforming and antenna techniques are considered for the energy propagation loss issue. In [7], the author used an RF power source operating at 2.45 GHz and 270 W to wirelessly charge a small hovering aircraft at 50 feet altitude. In [8], the authors presented that with the 2.7 GW transmitted power at a satellite in space, the power efficiency can be achieved 45% at the received antenna array located on the earth. Recently, some RF energy harvesting studies are having begun to be considered in mobile networks [9], [10]. In [9], an RF energy harvesting wireless network was proposed to be deployed in an uplink cellular network. A harvest-then-transmit protocol was proposed in [10] for a wireless broadcasting network. An increasing number of beamforming techniques are studied for the RF

energy harvesting application [11].

The RF wireless energy harvesting technology has drawn the attraction from the both industry and academic field. In the industry field, the RF energy harvesting can be used in many areas, such as WSNs, medical field, RFID and a large range of electronic devices. The RF energy harvesting is promising to change the way how electronic devices use power and is going to change people's life. In the academic field, there are a large number of researches regarding the RF energy harvesting that have been emerged. If we want to deploy the new energy harvesting node in communication networks, the traditional networks will have some changes, which gives a new perspective for researches to rethink the design of communication networks. Motivated by this, we study the energy harvesting technique for the wireless cooperative network in the thesis.

1.2 Contributions

In this thesis, we use the wireless energy harvesting technique in the traditional AF or

DF cooperative network. Regarding the energy efficiency, the algorithm is presented to find closed form solutions in the cooperative system with energy harvesting. For security issue, the energy harvesting is considered in a secure communication network and proposed approach is used to solve the secure beamforming optimization problem. Furthermore, the energy harvesting is deployed in the full-duplex cooperative network, and we address the beamforming optimization problem to maximize the achievable rate. Finally, we design a beamforming optimization for the full-duplex cooperative cognitive radio network with energy harvesting.

1.3 Publications Arising From This Research

1. S. Hu, Z. Ding and X. Cao, "Energy-efficient optimization in cooperative networks with wireless information and power transfer," in *CHINACOM 2015*, Shanghai, People's Republic of China, Aug. 2015.
2. S. Hu, Z. Ding, Q. Ni, W. Yu and Z. Song, "Energy efficiency in energy harvesting

cooperative networks with self-energy recycling,” in *Computer Aided Modelling and Design of Communication Links and Networks (CAMAD), 2015 IEEE 20th International Workshop on*, Guildford, Sept. 2015, pp. 59-63.

3. S. Hu and Z. Ding, “Secure communication in cooperative network with wireless information and power transfer,” *IET Signal Processing*, vol. 9, no. 9, pp. 663-669, Oct. 2015.

4. S. Hu, Z. Ding and Q. Ni, “Beamforming optimization in energy harvesting cooperative full-duplex networks with self-energy recycling protocol,” *IET Communications*, vol. 10, no. 7, pp. 848-835, May 2016.

5. S. Hu, Z. Ding, Q. Ni and Y. Yuan, “Beamforming optimization for full-duplex cooperative cognitive radio networks,” in *2016 IEEE 17th International Workshop on Signal Processing Advances in Wireless Communications (SPAWC)*.

1.4 Outline of the Thesis

This thesis is organized as follows: Chapter 2 discusses the background of wireless energy harvesting. The architecture of energy harvesting network, the energy harvesting technique, and its applications will be introduced. Besides, SWIPT will also be introduced, and related literature review will be given in chapter 2. Chapter 3 presents an algorithm to solve the energy-efficient optimization problem with the time switching relaying and power splitting relaying protocols. Chapter 4 studies the security issue in the energy harvesting cooperative network. Chapter 5 investigates the beamforming optimization problem in the full-duplex energy harvesting cooperative network, and a self-energy recycling protocol is introduced. In chapter 6, we study the beamforming optimization for the full-duplex cooperative cognitive radio network.

Chapter 2

Background

2.1 Architecture of Wireless Energy Harvesting Network

The architecture of RF energy harvesting network typically consists of three components. As shown in Fig. (2.1), the components are the information gateway, the RF power source, and the network node. The information gateway can be considered as the base station, the router or the relay in the communication network. The RF power source is capable of transmitting the dedicated energy-bearing signal to power the network node. The network node is the receiver. In the practical operation, the receiver harvests the energy-bearing signal to support it receiving the information-bearing signal transmitted from the information gateway. In some RF energy harvesting network architectures, the information gateway and the RF power source can be the same one.

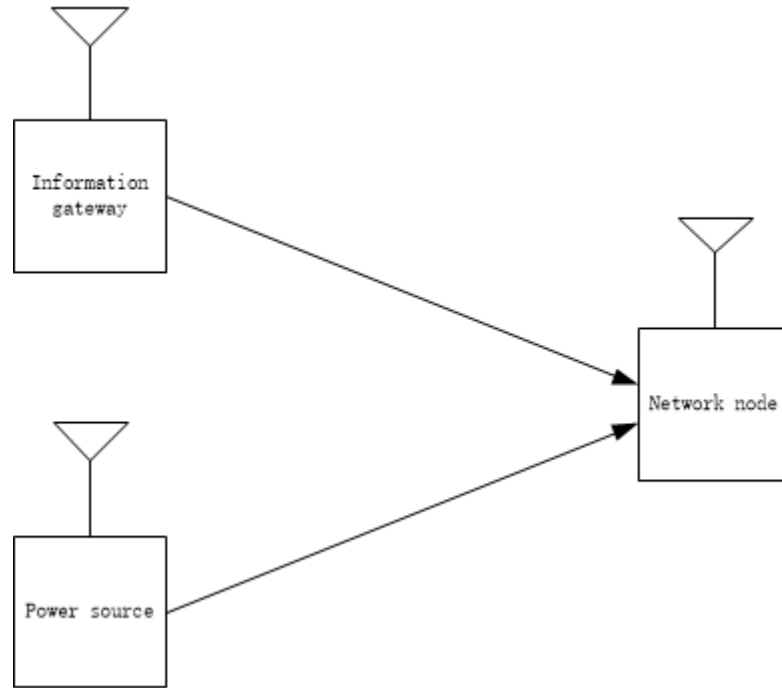

Figure 2.1: General architecture of the RF energy harvesting network.

In Fig. (2.2), the architecture of the network node is presented. In order to harvest the RF signal to convert it into the power, the network node should have an application operating network functions, a microcontroller processing the data from the application, an information transceiver for transmitting and receiving the information-bearing signal, a RF energy receiver harvesting the RF energy-bearing signal, a power management module deciding how to handle the collected energy and a battery for storing the redundant energy. For the power management module, it can use two protocols to manage the energy, i.e., harvest-use and harvest-store-use. The

harvest-use protocol is that the harvested power is immediately used to support the communication. In this protocol, the collected power should be always greater than the power requirement of the network node. Otherwise, the network node cannot operate. In the harvest-store-use protocol, the battery stores the harvested power. If the currently harvested power is smaller than the power requirement of the network node, the battery can provide the power that has been stored before to support the communication.

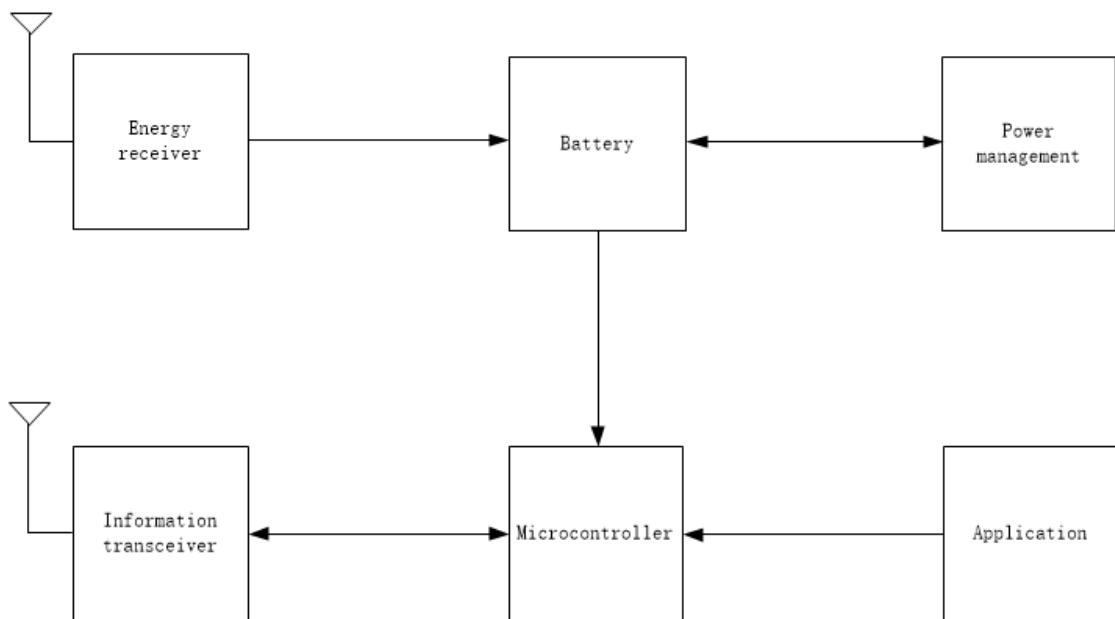

Figure 2.2: The architecture of the RF energy harvesting network node.

In the network node, the RF energy receiver is the part that collects the RF signal

and converts it into electricity. The RF energy receiver is composed of an antenna module, an impedance matching, a voltage multiplier and a capacitor [12]. The antenna module is capable of operating on various frequency bands to make the RF energy receiver harvest multiple power sources. The impedance matching is placed between the antenna module and the voltage multiplier to maximize the power transfer. The rectifier is the device for converting AC into DC. The capacitor delivers the converted power to the load. The architecture of the RF energy receiver is presented in Fig. (2.3).

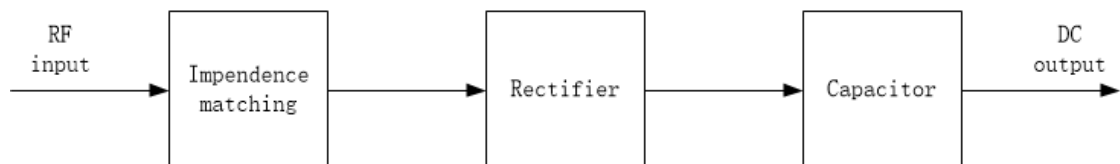

Figure 2.3: The architecture of the RF energy receiver.

2.2 Wireless Energy Harvesting Technique

For the RF energy harvesting, the harvested power can be calculated by Friis equation [1], which depends on the transmitted power, the wavelength, and the distance. The received power can be expressed by

$$P_R = \cos^2 \phi \frac{P_T G_T}{4\pi R^2} A_e, \quad (2.1)$$

where $\cos \phi$ is the polarization loss factor, P_T is the transmitted power, G_T is the transmitted antenna gain, R is the distance between antennas and A_e is the effective antenna area. $A_e = \frac{\lambda^2 G_R}{4\pi}$ where λ is the wavelength and G_R is the received antenna gain. The RF energy harvesting also has the distinctive properties compared the other energy harvesting methods, such as solar, wind, geothermal and vibrations. Renewable energy sources from nature are uncontrollable, hence the renewable energy harvesting does not ensure the QoS requirement. The RF energy harvesting technique overcomes the above limitation, and it uses a power source to broadcasting constant energy-bearing signal, and the transmitted power is controllable. The RF energy harvesting can be used in communication networks to charge remotely mobile devices. Due that the amount of harvested power depends on the distance, different energy harvesters placed in various locations have the obvious distinction of harvested

power. The most significant difference between the RF energy harvesting and other energy harvesting methods is that the RF energy harvesting can produce the stable power to the surrounding. Nevertheless, other energy harvesting methods are uncontrollable, passive to generate power. Hence, the RF energy harvesting is extremely suitable for the present-day communication network.

There are two kinds of power sources used in the RF energy harvesting, the dedicated source, and the ambient source. The dedicated power source uses directive antennas to meet the QoS requirement in the network with the constant transmitted power. The commercial application of the dedicated power source is the Powercaster [13] which operates at 915 MHz with 1 W or 3 W transmitted power. Due to the health and safety of human beings, there are some limitations regarding the output power of the dedicated RF power source, such as the FCC and the ISM regulation. For instance, the limitation of the output power is 4 W in the 900 MHz band. To meet mobile applications' QoS requirements, the dedicated power source is an appropriate method to satisfy that, because the dedicated power source can be fully configured. In [14], [15] and [16], the authors researched different power transfer schemes with the

mobile power source in WSNs. The ambient source is the RF signal that has been transmitted in the wireless channel. The RF energy harvester can opportunistically collect the ambient RF signal to charge itself. Some ambient RF signals could be harvested as power, such as the cell phone base station and the signal broadcasted from TV or radio towers. In [17], the authors analyzed the system performance of a sensor wirelessly powered by the ambient power source. In [18], the authors proposed a cognitive radio network model, in which the secondary user can collect RF signal transmitted from the primary user to power itself for the further use.

2.3 Applications of Wireless Energy Harvesting

A typical application of RF energy harvesting is WSNs. Deploying the RF energy harvesting in the WSN can be used as the power supply for the sensor node. In [3], a WSN is wirelessly charged by the ambient power source. The WSN powered by RF signals in the relaying network was presented in [19], [20], and [21].

Besides, the RF energy harvesting can also be used in the medical field. The node

with the medical purpose can be embedded in the human body, and the RF signal can be used for charging it. The RF energy harvesting technique results in the battery-free design for the circuit. In [4], an integrated circuit with the energy harvesting function was proposed, which can be applied in medical body sensors.

The RF energy harvesting technique is useful for RFID used in identification, tracking and inventory management [22]. Compared the traditional RFID tag, the tag with the energy harvester has the longer lifetime and the farther range. The RFID tag with the energy harvester can collect power and operate actively, which can process data and manage power [23].

The RF energy harvesting can also be used to power many wireless devices used in our daily life, such as wearable devices, electronic devices. In [24], a proposed circuit can be applied in mobile devices to harvest the ambient RF signal to supply devices operating.

2.4 Wireless Information and Power Transfer

The network node in the RF energy harvesting network has the information receiver and the energy receiver. Theoretically, it can collect energy and process information simultaneously. The RF signal can carry both information and energy, so the network node with the RF energy harvester can receive both information and power from the same RF waveform, which is referred as SWIPT and was firstly proposed in [25].

SWIPT is that the network node uses the same antenna module to perform the information reception and the energy harvesting. For instance, the wireless body sensor can be powered by the control signal. SWIPT achieves more efficient spectrum usage than that information and energy are transmitted in orthogonal time or frequency channels [6], [26]. SWIPT can be used in many scenarios with low-power electronic devices. The ideal receiver is capable of harvesting energy and receiving information from the same RF signal. Some works considered the ideal receiver to analyze the upper bound of the performance [25], [27], [28], [29].

However, the existing circuit cannot support simultaneously processing the information reception and the energy harvesting. The information reception and the energy harvesting cannot be operated on the same signal. Because the power

sensitivities of the information reception and the energy harvesting are different [6].

During the information receiving processing, the energy in the RF signal will be lost.

Hence, to design a practical implementation for SWIPT becomes a new research field.

2.4.1 Separated Structure

The separated structure is introduced in [6], in which the information reception and the energy harvester use different sets of the antenna. Their antennas receive the same RF signal. The structure is presented in Fig. (2.4). The separated structure can concurrently receive information and harvest energy. The separated structure is also referred as the antenna switching. MIMO technique could improve the performance for both the data reception and the energy harvesting with the antenna switching. For example, there are N antennas in total, in which L antennas serve the information reception, and $(N - L)$ antennas serve the energy harvester. In [6], multiple antennas were equipped with the either the information reception or the energy harvester, which significantly reduces the system complexity and is easy to implement. In [30], a low

complexity antenna switching was used at a relay node to achieve harvesting energy and decoding information. In the energy harvesting with the separated structure, the resource allocation can be performed at the power source when the CSI is available.

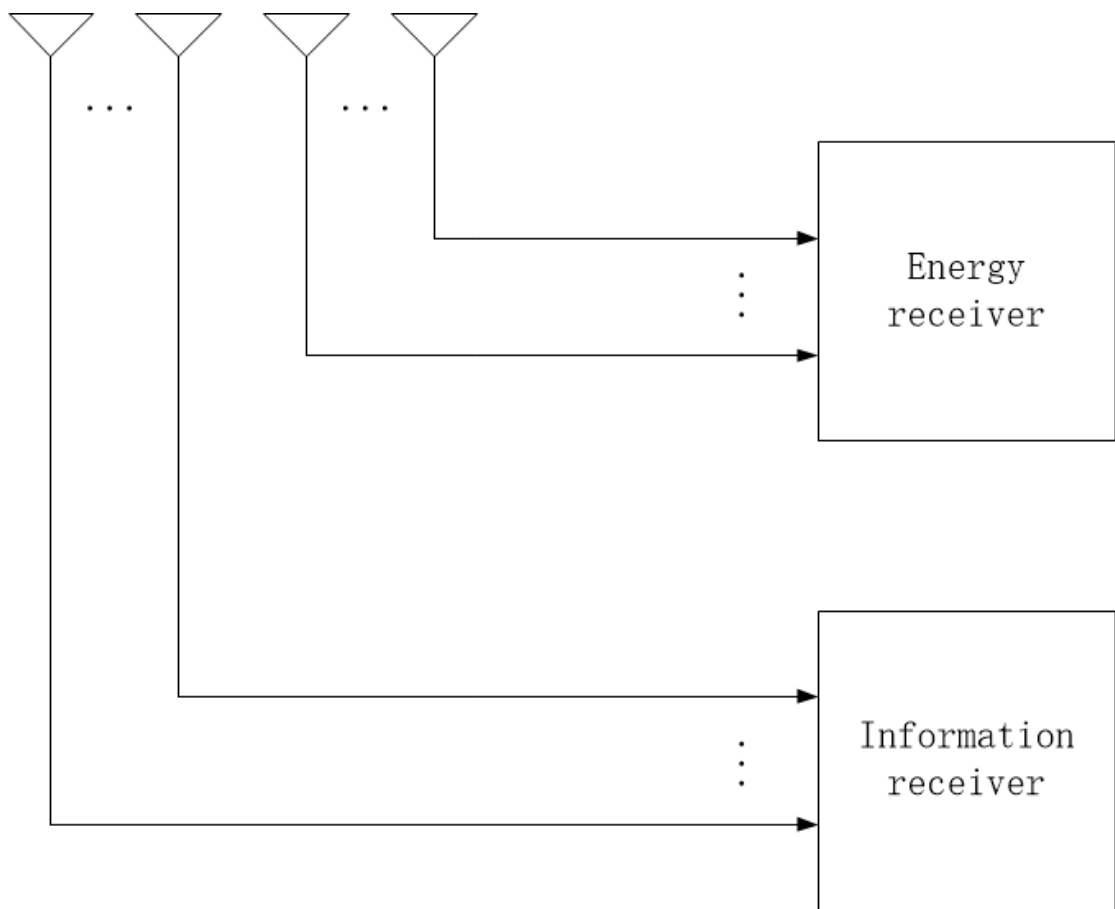

Figure 2.4: Separated receiver structure.

2.4.2 Time Switching and Power Splitting

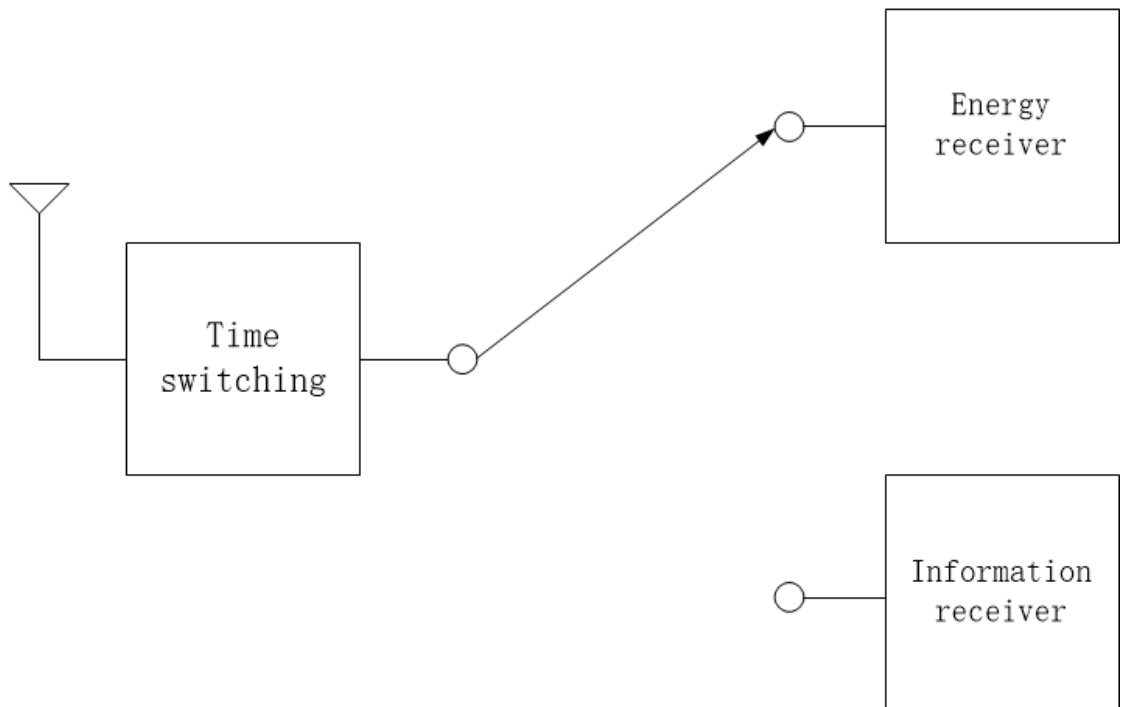

Figure 2.5: Time switching structure.

In [6], the authors proposed a co-located structure to achieve receiving information and harvesting energy for the network node in the RF energy harvesting network. The energy harvester and the information receiver can use the same antenna in the co-located structure. Compared to the separated structure, the co-located design simplifies the system complexity. There are two practical structures proposed, i.e.,

time switching and power splitting. According to the time switching, the energy harvesting node switches between collecting power and receiving information during different time allocations. The structure of the time switching is showed in Fig. (2.5).

When the energy harvester collects power, the harvested energy can be expressed as

$$P_{eh} = \eta P_t |h|^2, \quad (2.2)$$

where η is the energy conversion coefficient, P_t is the transmitted power at the power source, and h is the channel gain between the transmitter and the receiver.

When the information receiver operates, the information rate can be expressed as

$$R = (1 - \alpha)W \log \left(1 + \frac{P_t |h|^2}{\sigma^2} \right), \quad (2.3)$$

where α is the time switching coefficient that the duration of receiving energy at the receiver while $1 - \alpha$ represents the duration of receiving information at the receiver, W is the bandwidth and σ is the standard deviation of noise. The time switching allocation can be jointly optimized with the transmitted signal in different communication networks. The time switching requires accurate scheduling for the information and the energy. For the power splitting, the received RF signal is split into two streams, one is for the information reception, and the other one is for the energy

harvesting [31], [32]. The structure of the power splitting is illustrated in Fig. (2.6).

The harvested power in the power splitting is

$$P_{eh} = \eta\rho P_t |h|^2, \quad (2.4)$$

where ρ is the power splitting coefficient deciding the fraction of RF signals used for the energy harvesting receiver, $\rho \in [0, 1]$. So the information rate can be expressed as

$$R = W \log \left(1 + \frac{(1 - \rho)P_t |h|^2}{\sigma^2 + (1 - \rho)\sigma_p^2} \right), \quad (2.5)$$

where σ_p^2 is the processing noise. A tradeoff between the information rate and the harvested power can be analyzed by optimizing the ρ . The power splitting processes the information and the energy in one-time slot, so it achieves instantaneous SWIPT.

It is noted that the power splitting structure has more complex practical implementation than the time switching structure.

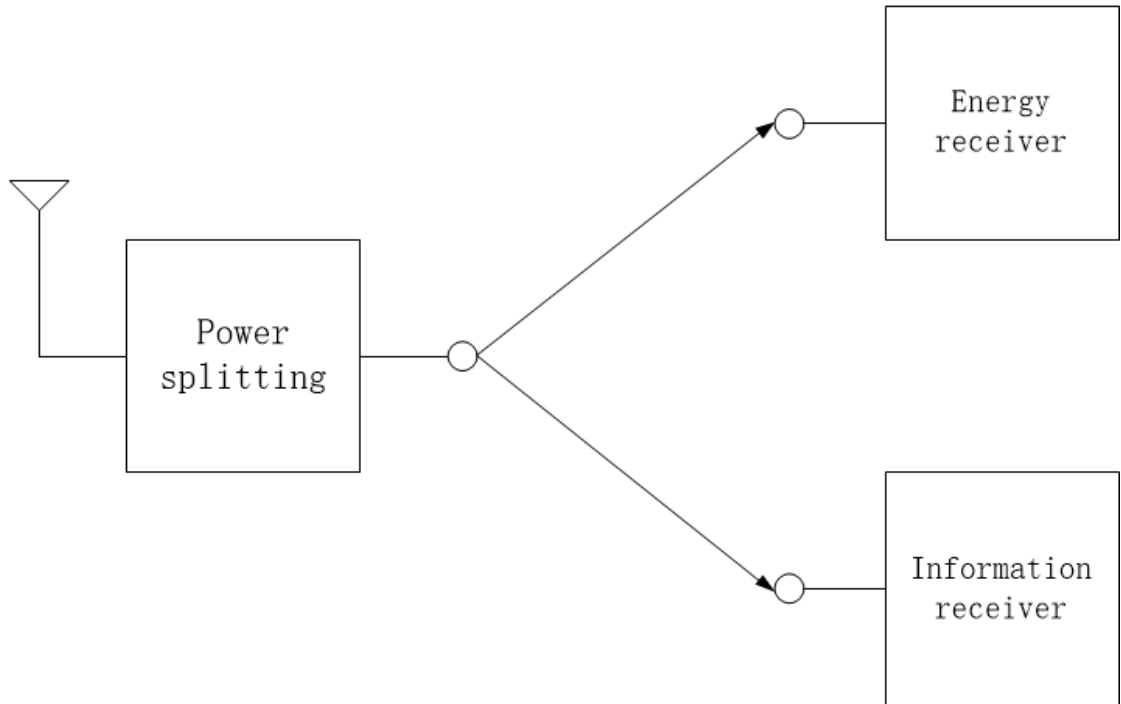

Figure 2.6: Power splitting structure.

2.4.3 Integrated Structure

In [26], the integrated structure was proposed, in which the information reception and the energy harvesting are implemented at the rectifier. The architecture is showed in Fig. (2.7). It is important to note that at the RF flow controller in the integrated structure, a time switching and a power splitting can be applied. When the circuit power consumption is considered as negligible compared to the signal power, the

co-located structure outperforms the integrated structure at the low harvested energy region [26].

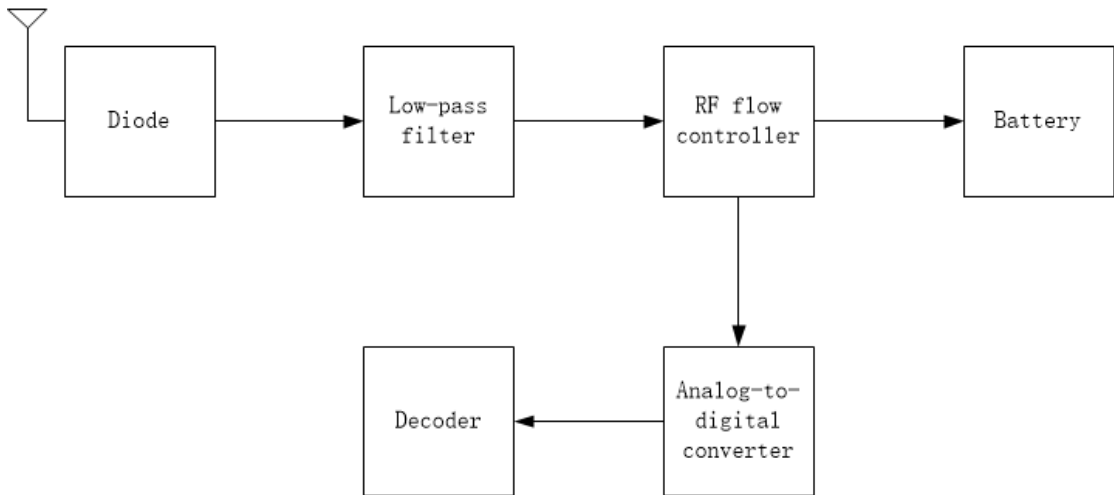

Figure 2.7: Integrated receiver structure.

To achieve efficient SWIPT, the design of communication networks should be changed. It was common to use the information rate to evaluate the reliability of the communication. But in the wireless energy harvesting network, the amount of harvested power becomes a parameter as important as the information rate. The channel fading and the interference have a significant impact on the system performance. The channel fading causes the degradation for the information reception and the energy harvesting in SWIPT. The interference attenuates the information

reception but is beneficial to the energy harvesting. In [33], the authors optimized the average data rate with the time switching structure under an average energy harvesting constraint in the interference fading channel. The authors in [34] also analyzed the power splitting in the fading channel.

2.5 Literature Review for SWIPT

2.5.1 Energy Harvesting Protocols

The energy harvesting protocol design is an important issue in the wireless energy harvesting network, in which the information receiver and the energy harvesting intends to use the same single antenna or multiple antennas. To meet QoS requirements, various tradeoffs are analyzed in the physical layer regarding the energy harvesting protocol. Scores of works considered the time switching and the power splitting protocol. The time switching is scheduling the arrival of information and energy in different time slots. The power splitting is dividing the received signal to

serve respectively the information receiver and the energy harvester.

Many researches regarding the energy harvesting protocol study were based on the point-to-point SISO system. In [6], [26], [34] and [35], the authors considered the energy harvesting in the fading channel. In [33], [36] and [37], the co-channel interference was involved in the wireless energy harvesting network study. In [6], the time switching was analyzed with the fixed transmitter power constraint or the flexibly transmitted power constraint; A uniform power splitting was also used in the receiver design, in which all antennas deployed the same power splitting ratio; The antenna switch employed in this paper implemented two groups of antenna to perform harvesting energy and receiving information; The achievable rate-energy regions for different energy harvesting protocols were illustrated.

A dynamic power splitting was proposed in [26], in which the receiver used dynamic ratio for the power splitting protocol. A unique scenario for the dynamic power splitting was demonstrated in this paper, i.e., the on-off power splitting. In the on mode, the receiver used the power splitting, in the off mode, the receiver only performed the energy harvesting. It is noted in this paper that when the circuit

consumption was considered in the system design, the on-off power splitting outperformed the power splitting.

In [35], it is proposed that the training assisted the power splitting receiver to improve the system performance. In the transmission phase, the transmitter was in the training phase and the information phase. The receiver used different power splitting ratios for the training phase and the information phase to achieve the better information rate. A non-adaptive and an adaptive power splitting were used in this paper. For the non-adaptive power splitting, the power splitting ratio was fixed. For the adaptive power splitting, the power splitting was changeable. It is proved that the adaptive power splitting outperformed the non-adaptive power splitting.

The wireless energy harvesting network with time-varying co-channel interferences in the fading channel was studied in [33]. According to the instantaneous CSI, an opportunistic time switching was used to estimate the system performance in delay-tolerant and delay-limited networks. Also, a joint optimization of the transmitted power and the receiver protocol was investigated. It is proposed that the receiver could either harvest energy or receive information according to the fading

channel information. Another result was that to achieve better system performance in the fading channel, it was reasonable to allocate the best channel gains for energy harvesting.

The power splitting was employed in both SISO and SIMO fading contexts [34]. In this paper, the authors proposed that if the fading channel gain surpassing the particular value, the receiver should perform power splitting according to a fixed coefficient, otherwise, the receiver only performed the information reception. The authors also proposed that a power splitting method was used in an SIMO model, in which a uniform power splitting method helped the system achieving the optimal performance.

A spectral efficient optimization problem was proposed in an OFDM system with the fading channel [36]. The problem of maximizing the spectral efficiency with the constraint of transmitted power and energy harvesting coefficient was non-convex. A convex technique was used in the paper, and the energy harvesting coefficient was found by the full search. Two low complexity algorithms were used to optimize the complexity. The same authors in [37] studied the energy efficiency problem. The

original problem to maximize the energy efficiency was also non-convex. An iterative algorithm was employed to solve the problem in the paper, and the algorithm could be guaranteed to converge to an optimal solution.

Some papers considered the wireless energy harvesting network in the SISO broadcasting model [32], [38]. In [32], a joint optimization problem of transmitted power allocation, sub-carrier allocation and energy harvesting coefficient was proposed for an OFDM network. The non-convex problem was solved by using fractional programming and iterative algorithm. In [38], the energy harvesting protocol was considered with TDMA and OFDM. The objective function in this paper was to maximize the sum-rate for all receivers with constraints of transmitted power and harvested energy. A TDMA-based and an OFDM-based transmission designs were proposed in the article.

In the above mentioned papers, the energy harvesting protocols are mainly investigated in single antenna communication network models. Some researchers studied the energy harvesting protocols in the fading channel to find an optimal energy harvesting coefficient, which improves the system performance for the

wireless energy harvesting network. However, some researcher pointed out that the single-antenna node could not achieve the high energy transfer efficiency, hence, there are other papers studying the energy harvesting technique in the multi-antenna network, in which the multi-antenna network could provide the better system performance than the single-antenna network. In the next subsection, some papers regarding the energy harvesting study in the multi-antenna network will be discussed.

2.5.2 Energy Harvesting for Multi-Antenna Network

2.5.2.1 Beamforming Design for Resource Allocation

There is a major challenge regarding the wireless energy harvesting, which is the degradation of energy according to the transmission distance. The single-antenna network with the energy harvesting node transmits power via omnidirectional emission due to the broadcasting nature of the wireless communication. In this situation, the multi-antenna can assist the transfer of energy. The multi-antenna

transmitter produces more transmitted power for energy harvesters than the single antenna transmitter. Also, the beamforming technique can improve the energy transfer efficiency for SWIPT [39] and has been considered as a potential way to practically implement the energy harvesting [8], [40], [41]. In the wireless energy harvesting network, the beamforming design is used to delivery information and energy from a transmitter to several receiver nodes. It is showed in Fig. (2.8) regarding a multi-antenna SWIPT network.

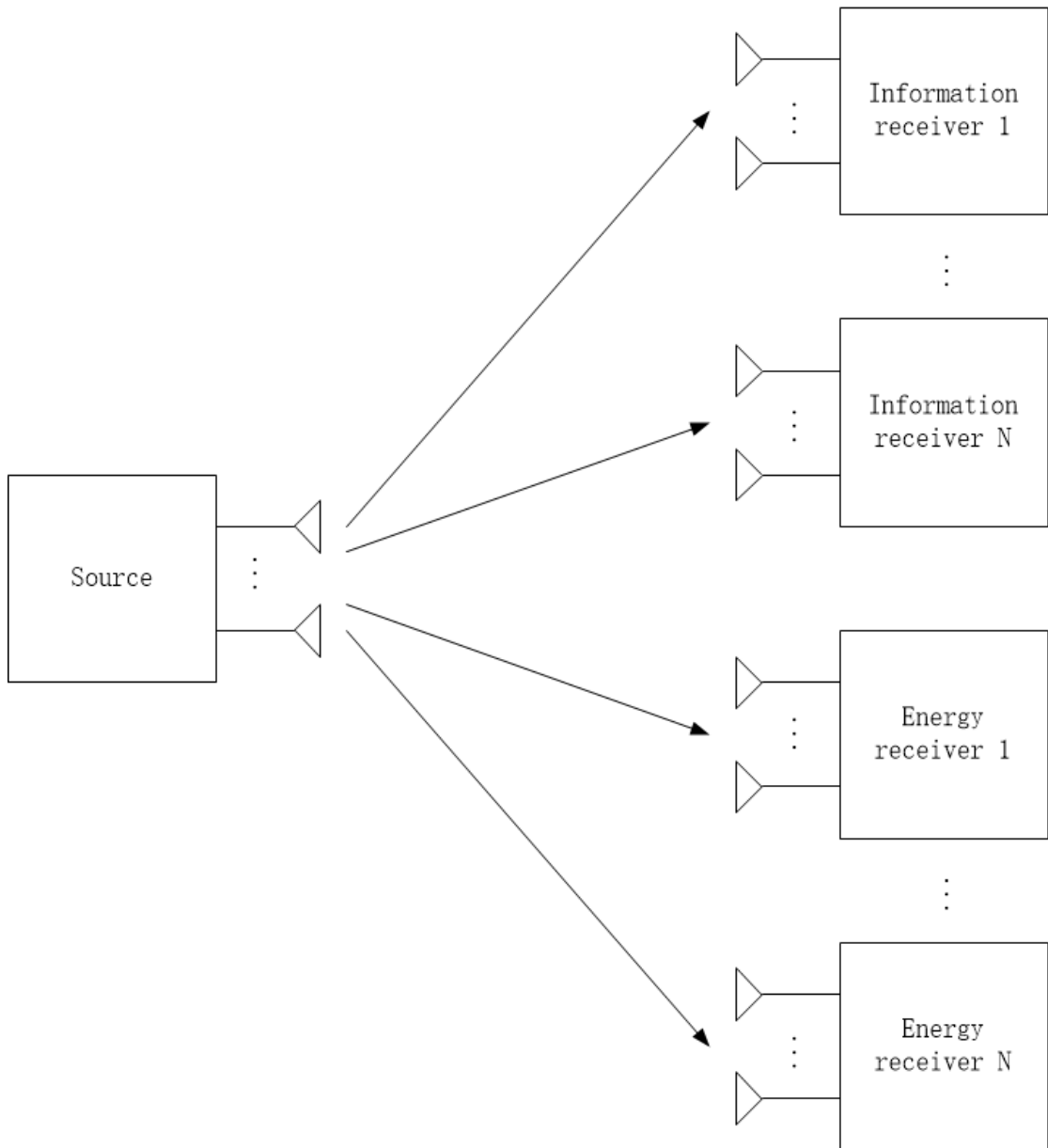

Figure 2.8: System model for multi-antenna SWIPT network.

The idea of using beamforming in the wireless energy harvesting network had been firstly arisen in [6], in which the multi-antenna transmitter employed the beamforming to delivery information for a multi-antenna information reception and to

transfer power for a multi-antenna energy harvester. In [39], the beamforming technique was deployed to improve the energy efficiency of the MIMO network. A joint optimization problem regarding the transmitted power and the energy harvesting coefficient was solved. The study in [42] was to optimize the harvested power with the constraint of information rate, in which the non-convex problem was solved by the semidefinite relaxation and the solution was theoretically proved as always rank-one.

The MISO model for SWIPT network with multiple information receivers and energy harvesters was studied in [43] and [44]. A problem designed to optimize the harvested energy for energy harvesting nodes with constraints of each SINR for information receivers and the total available power was proposed in [43]. A standard interior-point method was used to solve this problem. In [44], the total harvested energy was maximized for energy harvesters with the constraint of QoS requirements for each information receiver.

In [45], the authors proposed to use multiple power splitting receivers instead of multiple separated information receivers and energy harvesters in the MISO network. A joint optimization problem of the transmitted beamforming and the power splitting

coefficient was proposed, and it was solved via the semidefinite relaxation.

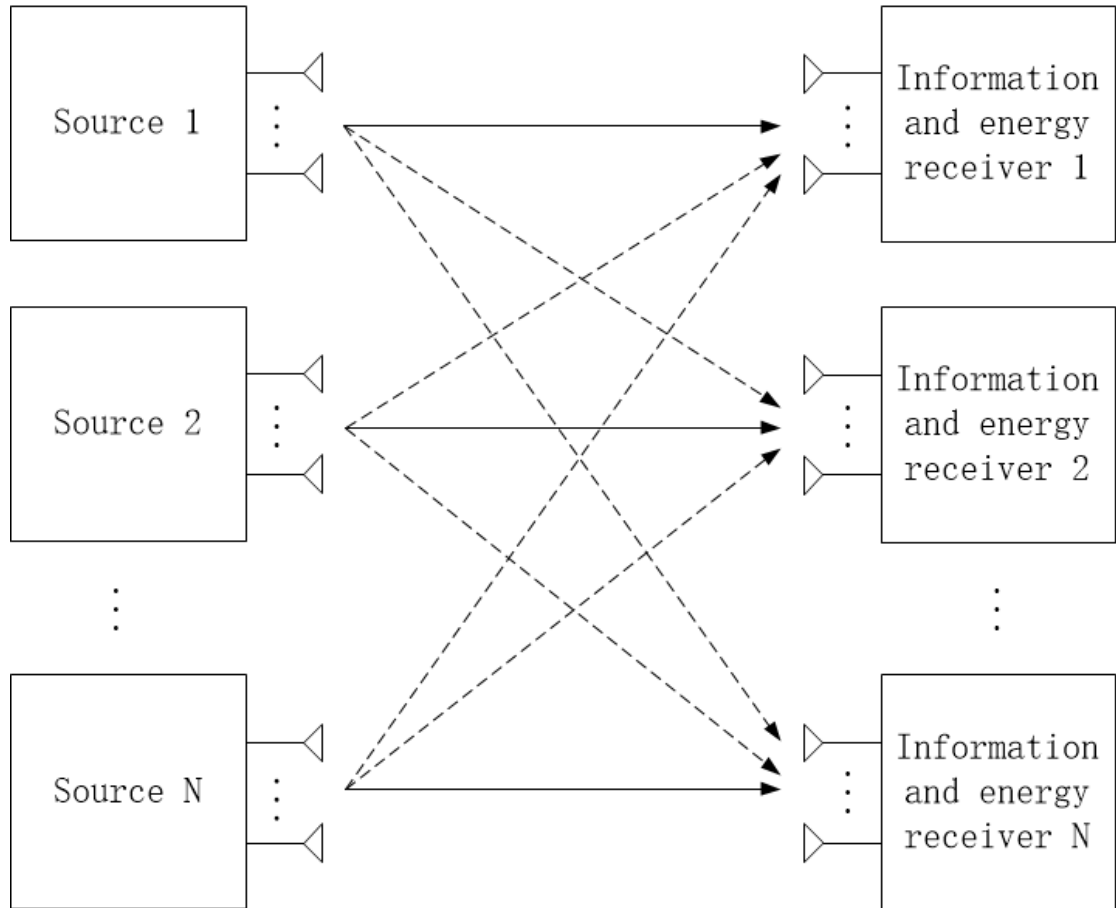

Figure 2.9: The co-channel interference SWIPT network.

The scenario of the co-channel interference was considered in SWIPT. The multi transmitter-receiver pairs are significant for SWIPT; its structure can be showed in Fig. (2.9). The multi-nodes share the spectrum. This case is different from the single transmitter-receiver pair, in which information and interference signals co-exist in

channels. Interference collaboration has become a challenge for SWIPT. An antenna selection technique and interference management were introduced in [46], it was proved that interference signals was used to be considered as harmful for communications but became useful in wireless energy harvesting networks. A diagonalization block precoding was used in [47], in which receivers switched between the information reception and the energy harvester to improve the system performance. In [48], a beamforming optimization problem was designed in a MISO network with multiple transmitter-receiver pairs. Different beamforming designs were used in this paper, and a joint optimization of the beamforming and the power splitting coefficient was solved via semidefinite relaxation. Moreover, an adaptive beamforming design was proposed in this paper. In [49] and [50], the authors studied SWIPT in MIMO model with the co-channel interference. The scenario of two transmitter-receiver pairs was considered in [49], in which receivers used the time switching structure. The information rate was analyzed by an iterative water-filling method. In [50], the research in [49] was extended to a k-user multiple transmitter-receiver pairs network. Beamforming designs were proposed in this paper,

and the rate-energy region was also analyzed. A non-convex optimization was solved by proposed iterative algorithm.

The authors proposed a multi-point network with SWIPT in [51], in which a central processor assisted the transmission between transmitters and multi-point nodes. A non-convex optimization problem of minimizing the available power with constraints of QoS requirements for information receptions and minimum harvested energy for energy collectors was solved by a proposed suboptimal iterative algorithm.

In the above mentioned papers, the beamforming technique was studied in the energy harvesting multi-antenna network. It is proved that the beamforming technique can improve the system performance with SWIPT. Some beamforming optimization problems were proposed in the above papers and their optimal solution were found. In the next subsection, some researchers focused on the beamforming studies regarding the security problem with SWIPT.

2.5.2.2 Beamforming Design for Secure Communication

Some studies focused on the secure issue regarding the wireless energy harvesting network, and beamforming could also be used in secure communication networks for SWIPT. The authors studied two optimization problems in [52], one was maximizing the secrecy rate with the constraint of minimum harvested energy, another was maximizing the harvested energy with the constraint of secrecy rate. The proposed problems were non-convex, and the authors used the one-dimension method and the semidefinite relaxation to solve problems. In [31], the authors used the artificial noise to improve the system performance from the security's perspective. The proposed problem in this paper was to minimize the transmitted power with the constraint of information rate.

The authors considered a secure issue for a TDMA-based broadcasting network with multiple information receiver and eavesdroppers. A semidefinite relaxation algorithm was used to solve the power allocation with the consideration of QoS.

In [53], a three nodes MIMO network was used to study the secure issue, in which the energy harvester was malicious to hear information. The original non-convex beamforming optimization problem was intended to maximize the secrecy rate with

constraints of transmitted power and minimum harvested energy. An inexact block coordinate descent algorithm was proposed in the paper for this issue.

The secure issue was considered in a cognitive radio network with SWIPT [54]. In the proposed network, the authors optimized the energy harvesting efficient and the transmitted power via the semidefinite relaxation. Two suboptimal algorithms were also proposed in the paper.

In the above mentioned papers, the secure issue in the wireless energy harvesting multi-antenna network was considered. So far, we have reviewed some literatures regarding the energy harvesting in the point-to-point communication network. To practically implement the energy harvesting in the communication network, the fading and attenuation problems should be overcome. Some researchers pointed out that the cooperative network could improve the system performance for the energy harvesting network by deploying the relay node in the network. In the next subsection, some studies regarding the cooperative network will be introduced.

2.5.3 Cooperative Relaying Network

2.5.3.1 Introduction of Conventional Relaying Network

For the point-to-point communication network, the channel state between nodes cannot be guaranteed to support the continuous communication due to the multipath fading. In the cooperative relaying network, the source node communicates with the destination node through the relay node. The diversity in the cooperative network is improved [55], because the additional paths are provided for the reception. Each node in the cooperative network has a closer distance as the transmission is split into several phases, therefore the pathloss impact becomes slighter. The source-destination transmission is reliable with the assist of the relay node. The relay node uses different relaying protocols to assist the cooperative network transmission. In the thesis, the works are mainly based on the AF and DF protocol, therefore these two protocols will be discussed here.

The AF relaying protocol was firstly proposed in [56]. In the AF protocol, the relay node amplifies the received signal from the source node and then transmits it to the destination node. If the relay node has the minimal computing power, the AF

protocol is the ideal and straightforward way to deploy in the cooperative network.

The DF relaying protocol is another common protocol used at the relay node. In this protocol, the relay node detects the signal from the source node and then transmits it to the destination node. If the relay node has the enough computing power, it can employ the error correcting code to correct the received bit error [57].

As the cooperative relaying network could overcome fading to increase the transmission efficiency and reliability, this network is suitable for the wireless energy harvesting network. In the thesis, the energy harvesting technique is studied in the wireless cooperative network. In the next subsection, some researches regarding the wireless energy harvesting cooperative network will be discussed.

2.5.3.2 Relaying Protocols with Energy Harvesting

The cooperative relaying network is promising to implement practically the wireless energy harvesting because it is powerful to improve the system performance in communications. In the wireless energy harvesting network, the relay node can be

powered by signals. For instance, a source node is willing to communicate to a destination node with the help of a relay node. The relay node has a limited battery to support the transmission. If the relay node can wirelessly harvest energy, the relay node can have enough power to support the transmission. Also, the relay node can assist the communication to overcome fading and attenuation. Hence, the energy harvesting relay can improve the transmission reliability.

The design of the cooperative relaying network with energy harvesting is different from it without energy harvesting. The deployment of energy harvesting node should be considered in the cooperative relaying network. Typically, there are three nodes in the cooperative relaying network, which are the source node, the relay node, and the destination node. The relay node delivers information from the source node to the destination node. Energy harvesting can be deployed on one node or multiple nodes in the cooperative relaying network. Some cooperative schemes have been widely used for nowadays applications, such as AF and DF. The authors in [58] proposed that DF relaying scheme be more practical to implement for SWIPT.

In [59], the authors employed the time switching in the cooperative relaying

network. In proposed network, the relay node used remaining power to delivery information. The outage probability of the relay node was obtained in a close form.

The multi-antenna is important for the cooperative relaying network with energy harvesting. In [30], an MIMO relaying was considered with energy harvesting. A dynamic antenna switching was deployed to allocate sets of the antenna to perform information receiving or energy harvesting according to CSI. The outage probability was analyzed in the paper.

The authors in [60] proposed the time switching based relaying protocol and the power splitting based relaying protocol for the wireless cooperative relaying network using AF. Capacities and outage probabilities for two proposed protocols were analyzed in the paper. The same authors proposed an adaptive time switching protocol for AF and DF wireless cooperative relaying network [61]. The duration for harvesting energy was dynamically changed according to CSI. The achievable throughput was analyzed. The concern of user scheduling was proposed in [62], the max-min selection criterion and an optimal strategy for DF relaying network were investigated.

In this subsection, the papers about the wireless energy harvesting network are discussed. From those papers, it can be seen that the cooperative relaying network could improve the system performance with SWIPT. In the next subsection, some resource allocation problems in the energy harvesting relaying network will be introduced.

2.5.3.3 Resource Allocation for Energy Harvesting Relaying Network

Resource allocation algorithms is another research area for the wireless energy harvesting cooperative relaying network. The authors in [63] studied the resource allocation in multiple transmitter-receiver pairs DF relaying network. The relay node was able to harvest power and assist the transmission. The usage of harvested power in the relay node was optimized for each transmitter-receiver pair.

In [64], the model used was that multiple sources transmitted information to one destination with the help of one relay. The sources and the relay were able to harvest

power. A joint resource allocation and energy harvesting problem was proposed to maximize the sum rate, and an iterative algorithm solved the problem. Also, an energy cooperation model for the two-way relaying network was analyzed in [65].

Some works focus on the application of SWIPT for the two-way cooperative relaying network. In [66], a two-way cooperative relaying network with energy harvesting was considered. In fading channels, the relay node assisted two nodes to exchange information and the power splitting was employed in the paper. In [67], two single-antenna nodes wirelessly powered by multiple single-antenna relay nodes shared information. The sum rate of all nodes was optimized with constraints of transmitted power and harvested energy. The work in [68] studied a robust optimization problem for the two-way cooperative relaying network. The semidefinite relaxation, S-procedure, and successive convex approximation were used in the paper to obtain the optimal solution.

In this subsection, some resource allocation algorithms are discussed regarding the wireless energy harvesting cooperative network and some methods to find the optimal solution are introduced. Based on the above researches, the works in this thesis are

mainly focused on the resource allocation algorithm for the wireless energy harvesting cooperative network. In the next chapter, these works will be introduced.

2.6 Chapter Summary

This chapter provides a background of wireless energy harvesting. The architecture of wireless energy harvesting network is introduced. Some wireless energy harvesting techniques and applications are explained. Also, the concept of SWIPT and different SWIPT receiver structures are discussed in detail. Literature reviews regarding SWIPT are also provided in this chapter.

Chapter 3

Energy-Efficient Optimization in Cooperative Networks with Wireless Information and Power Transfer

3.1 Introduction

The concept of energy efficiency (bit-per-Joule) in the wireless communication has drawn much attention in industry and academia fields [69], [70], [71]. For the wireless energy-constrained network, the energy-efficient design is a significant issue [72], [73], [74]. Improving the energy efficiency can ensure that the wireless communication system utilizes energy in a more environment-friendly way.

In the chapter, a DF cooperative relaying network is considered, in which the energy harvesting relay is wirelessly powered by RF signals transmitted from the source node and then uses the harvested energy to support the relay transmission. The energy-efficient maximization problem in the cooperative wireless network is considered. The energy-efficient maximization problem is a ratio of the channel

capacity and overall power consumption in the block time. Notably, two energy-efficient maximization problems are formulated in this chapter based on the time switching relaying protocol and the power splitting relaying protocol, respectively. However, original formulated maximization problems are not in a standard convex form, which is not solvable. In this situation, the nonlinear fractional programming is useful to reconstruct proposed problems into a convex form. After the transformation, the Lagrange multiplier method and the gradient method are used to solve problems. The simulation results are also presented in the chapter to verify the effectiveness of proposed method.

3.2 System Model

The considered wireless cooperative network includes one source-destination pair and one relay. Each node in the network is equipped with a single antenna. There is no direct link between the source node and the destination node, i.e., the source node communicates with the destination node via an energy harvesting relay. The

source-to-relay channel and the relay-to-destination channel are modeled as quasi-static block fading channels. The channel gains are denoted as h and g . The distances from the source to the relay and from the relay to the destination are denoted by d_1 and d_2 , respectively. The considered network is demonstrated in Fig. (3.1). The perfect channel state information is assumed available at the destination node. The energy harvesting relay can harvest energy from the source node and utilize the energy to relay the source information and this assumption is used in [60]. The battery capacity of the energy harvesting relay is assumed as infinite. The DF scheme is employed in the cooperative network. The two relaying protocols for energy harvesting are considered in this paper. Detailed analyzes regarding the time switching-based relaying protocol and the power splitting-based relaying protocol are given in the following sections. Assuming that at the relay, the power consumed to process the harvested energy is negligible, when compared to the power used in transmitting information to the destination.

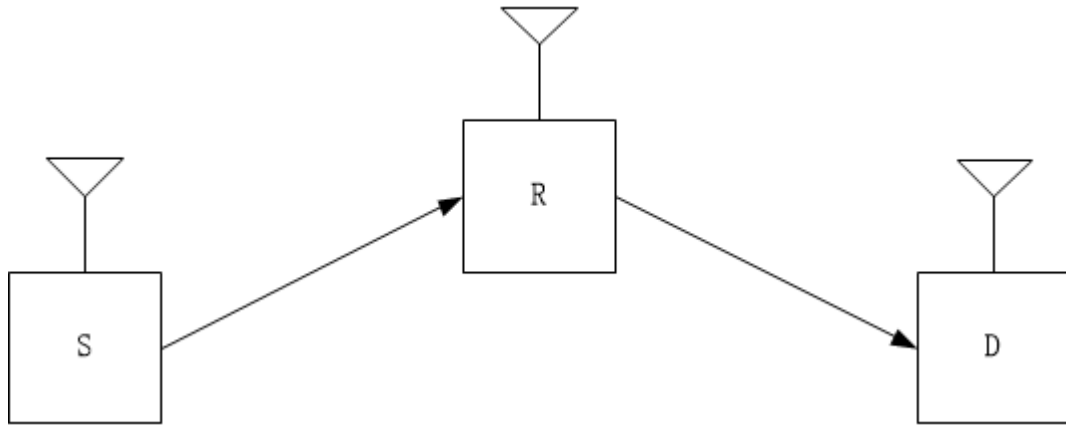

Figure 3.1: System model for the relay node assisting communication between the source node and the destination node.

3.3 Energy-Efficient Optimization based on Time Switching

Relaying Protocol

In this section, the energy-efficient optimization is discussed with the time switching relaying protocol. The transmission model with the time switching relaying protocol and the corresponding optimization problem are given as follows.

3.3.1 Time Switching Relaying Protocol

The whole transmission process is operated in the block time, denoted by T . The information transmission process is split into three phases. In the first phase, the source node transmits RF signals to power the energy harvesting relay node for α time, $0 \leq \alpha \leq 1$. During the rest of the block time $(1 - \alpha)$, the information is transmitted from the source node to the relay node and then to the destination node.

3.3.2 System Transmission Model

The energy harvesting relay first harvests the energy from the source and then detects the transmitted signal from the source. The received signal at the relay can be expressed as

$$y_r = \frac{1}{\sqrt{d_1^m}} \sqrt{P_s} h s + n_r, \quad (3.1)$$

where d_1 is the distance between the source node and the relay node, m is the path loss exponent, P_s is the transmitted power, h is the channel gain from the source node to the relay node which is modeled as quasi-static block-fading and frequency non-selective parameters, the channel is unchanged in the block time and independent

and identically distributed from one block to the next block, following a Rayleigh distribution, and s is the normalized transmitted signal with the unit power. n_r is the sum of the baseband AWGN from the receiving antenna and the sampled AWGN from the RF band to baseband conversion [60], following $\mathcal{CN}(0, \sigma_r^2)$.

The energy harvesting relay harvests energy from the source in α time, in which the harvested energy is given by

$$E = \frac{\eta(P_s|h|^2 + d_1^m \sigma_r^2)}{d_1^m} \alpha T, \quad (3.2)$$

where η is the energy conversion efficiency coefficient at the relay node.

We assume that the energy harvesting relay is operated with the DF protocol, and it can decode the source information successfully. The received signal at the destination is given by

$$y_d = \frac{1}{\sqrt{d_2^m}} \sqrt{P_r} g s + n_d, \quad (3.3)$$

where d_2 is the distance from the relay to the destination, P_r is the power transmitted from the relay; g is the channel gain between the relay and the destination which is also modeled as quasi-static block-fading and frequency non-selective parameters, the channel is stable in the block time and independent and

identically distributed from one block to the next block, following a Rayleigh distribution. n_d is the sum of the AWGN from the receiving antenna and the noise from the conversion, following $\mathcal{CN}(0, \sigma_d^2)$.

According to the time switching relaying protocol, the relay uses the harvested energy in α time to forward the re-encoded information to the destination in the rest of the time. The transmitted power at the relay can be expressed as

$$P_r = \frac{2\eta(P_s|h|^2 + d_1^m\sigma_r^2)\alpha}{d_1^m(1-\alpha)}, \quad (3.4)$$

In the case of the cooperative network using DF protocol without the direct link between the source node and the destination node, the channel capacity with the time switching relaying protocol can be calculated as

$$C^{TS} = \min(C_{SR}^{TS}, C_{RD}^{TS}), \quad (3.5)$$

where C_{SR}^{TS} and C_{RD}^{TS} are channel capacities from the source to the relay and from the relay to the destination, respectively. Based on the time switching energy harvesting relaying protocol, C_{SR}^{TS} and C_{RD}^{TS} can be expressed as

$$C_{SR}^{TS} = \frac{1-\alpha}{2} \log_2 \left(1 + \frac{P_s|h|^2}{d_1^m\sigma_r^2} \right), \quad (3.6)$$

and

$$C_{RD}^{TS} = \frac{1 - \alpha}{2} \log_2 \left(1 + \frac{2\eta(P_s|h|^2 + d_1^m \sigma_r^2)|g|^2 \alpha}{d_1^m d_2^m (1 - \alpha) \sigma_d^2} \right), \quad (3.7)$$

where σ_r^2 and σ_d^2 are variances of n_r and n_d .

3.3.3 Problem Formulation

In this subsection, we consider the ratio between the system channel capacity and the overall power consumption in one transmission block time, which is the expression of the energy efficiency. It is assumed that each node has a constant circuit power consumption for signal processing, which is independent of the power used for transmitting signal. We denote P_1 , P_2 and P_3 by the consumed circuit power in the source, the relay, and the destination, respectively.

In the time switching relaying protocol, nodes are activated in the allocated time slot. The source node operates during the energy transfer time and information delivering to the relay node. The relay node operates for the whole transmission block. The destination node operates during the information being transmitted from the relay to itself. So the total consumed energy with the time switching relaying protocol in

this cooperative wireless network is given by

$$E_c^{TS} = P_1 \left(\frac{1 + \alpha}{2} \right) T + P_2 T + P_3 \left(\frac{1 - \alpha}{2} \right) T + P_s \left(\frac{1 + \alpha}{2} \right) T, \quad (3.8)$$

This work aims to maximize the energy efficiency in the considered model. The energy efficiency can be expressed as the ratio of the channel capacity and the total consumed power. With the time switching relaying protocol, the optimization problem is given by

$$\begin{aligned} & \max_{P_s, \alpha} \frac{C^{TS}}{E_c^{TS}}, \\ & s. t. C1: P_s \leq P_s^{max}, \\ & C2: P_r \geq P_r^{min}, \\ & C3: C^{TS} \geq C^{min}, \\ & C4: P_s \geq 0, \\ & C5: 0 \leq \alpha \leq 1. \end{aligned} \quad (3.9)$$

where the predefined variable P_s^{max} is the maximum transmitted power limitation at the source. P_r^{min} is the minimum power requirement at the relay to forward the information to the destination. C^{min} is the minimum required channel capacity to meet the QoS criterion.

One can easily verify that the proposed problem above is not a convex optimization problem because the objective function is a ratio of the channel capacity and total consumed power. The solution of this formulated problem is given in following sections.

3.4 Energy-Efficient Optimization based on Power Splitting Relaying Protocol

In this section, we focus on energy-efficient optimization based on the power splitting-based relaying protocol. The transmission model with power splitting relaying protocol and the optimization problem are given as follows.

3.4.1 Power Splitting Relaying Protocol

In the cooperative wireless network with the power splitting relay, one transmission block is split into two phases. At the end of the first phase, the power splitting relay

receives observations with the transmitted power P_s from the source and then splits it into two streams. One part of the power ρP_s is the harvested energy for the next phase transmission. The rest of power $(1 - \rho)P_s$ is used for information decoding procedure at the relay.

3.4.2 System Transmission Model

The energy harvesting relay receives the power and the information in the first phase.

The received signal is given by

$$y_r = \frac{1}{\sqrt{d_1^m}} \sqrt{(1 - \rho)P_s} h s + n_r, \quad (3.10)$$

where d_1^m , m , h and s are defined as same as them in the last section. $n_r = \sqrt{(1 - \rho)n_r^a} + n_r^c$, the baseband AWGN n_r^a is reduced by the power splitting receiver and n_r^c is the noise from the conversion.

The relay harvests energy from the source in the first phase, in which the harvested energy can be expressed as

$$E = \frac{\eta \rho (P_s |h|^2 + \sigma_r^2) T}{d_1^m 2}, \quad (3.11)$$

where η is the energy conversion coefficient at the relay.

The considered model is operated under the DF mode, and it is assumed that the relay can decode the source information successfully. The received signal at the destination can be expressed as

$$y_d = \frac{1}{\sqrt{d_2^m}} \sqrt{P_r} g s + n_d, \quad (3.12)$$

where d_2^m , P_r , g and n_d are defined as same as them in the last section.

In the power splitting relaying protocol, the relay utilizes the harvested energy to assist the next transmission phase. The transmitted power of the relay is given by

$$P_r = \frac{\eta \rho (P_s |h|^2 + \sigma_r^2)}{d_1^m}, \quad (3.13)$$

The channel capacity in this model can be calculated as

$$C^{PS} = \min(C_{SR}^{PS}, C_{RD}^{PS}), \quad (3.14)$$

where

$$C_{SR}^{PS} = \frac{1}{2} \log_2 \left(1 + \frac{(1 - \rho) P_s |h|^2}{d_1^m \sigma_r^2} \right), \quad (3.15)$$

and

$$C_{RD}^{PS} = \frac{1}{2} \log_2 \left(1 + \frac{\eta \rho (P_s |h|^2 + \sigma_r^2) |g|^2}{d_1^m d_2^m \sigma_d^2} \right), \quad (3.16)$$

where σ_r^2 and σ_d^2 are variances of n_r and n_d , respectively.

3.4.3 Problem Formulation

To formulate the energy efficiency maximization problem with the power splitting relaying protocol, we first find the overall energy consumption as follows.

$$E_c^{PS} = \frac{1}{2}P_1T + P_2T + \frac{1}{2}P_3T + \frac{1}{2}P_sT, \quad (3.17)$$

where P_1 , P_2 and P_3 are the constant circuit power consumption at the source node, the relay node, and the destination node, respectively.

The energy efficiency maximization problem with the power splitting relaying protocol can be expressed as

$$\begin{aligned} & \max_{P_s, \rho} \frac{C^{PS}}{E_c^{PS}} \\ & s. t. C1: P_s \leq P_s^{max}, \\ & C2: P_r \geq P_r^{min}, \\ & C3: C^{PS} \geq C^{min}, \\ & C4: P_s \geq 0, \\ & C5: 0 \leq \rho \leq 1. \end{aligned} \quad (3.18)$$

where P_s^{max} is the maximum transmitted power at the source. P_r^{min} is the minimum power requirement at the relay to forward the information to the destination. C^{min} is the minimum required channel capacity with a targeted QoS.

This problem is also not a convex problem. In the next section, we analyze the solution to solve these optimization problems.

3.5 Solution of Formulated Optimization Problems

The two proposed problems are not in the standard convex form. However, the problem can be transformed by exploring the properties of the nonlinear fractional programming. According to the parametric method, we introduce a new variable q^* to denote the optimum energy efficiency for proposed problems, which is the ratio of channel capacity C and power consumption E_c . q^* can be expressed as

$$\begin{aligned}
 q^* &= \frac{C^*}{E_c^*} \\
 &= \max_{P_s} \frac{C}{E_c}, \tag{3.19}
 \end{aligned}$$

By introducing the property of nonlinear fractional programming, the objective

functions of the problem (3.8) and (3.18) can be transformed into a subtractive form, which is equivalent to its original one [69]. Hence, the reformulated parametric problems can be expressed as

$$\begin{aligned}
 & \max_{P_s, \alpha} C^{TS} - q_1^* E_c^{TS} \\
 & s. t. C1: P_s \leq P_s^{max}, \\
 & C2: P_r \geq P_r^{min}, \\
 & C3: C^{TS} \geq C^{min}, \\
 & C4: P_s \geq 0, \\
 & C5: 0 \leq \alpha \leq 1.
 \end{aligned} \tag{3.20}$$

and

$$\begin{aligned}
 & \max_{P_s, \rho} C^{PS} - q_2^* E_c^{PS} \\
 & s. t. C1: P_s \leq P_s^{max}, \\
 & C2: P_r \geq P_r^{min}, \\
 & C3: C^{PS} \geq C^{min}, \\
 & C4: P_s \geq 0,
 \end{aligned}$$

$$C5: 0 \leq \rho \leq 1. \quad (3.21)$$

where $q_1^* = \frac{C^{TS}(P_s^*, \alpha^*)}{E_c^{TS}(P_s^*, \alpha^*)}$ and $q_2^* = \frac{C^{PS}(P_s^*, \rho^*)}{E_c^{PS}(P_s^*, \rho^*)}$, which represent the optimal maximum of energy efficiency in the cooperative network with different energy harvesting relaying protocols. Here we have the theorem to show the relationship between the transformed problem and the original problem.

Theorem 1. *The optimum energy efficiency $q^* = \frac{C^*}{E_c^*} = \max_{P_s} \frac{C}{E_c}$ if and only if q^* satisfies*

$$\begin{aligned} & \max_{P_s} C - q^* E_c \\ & = C^* - q^* E_c^* \\ & = 0, \end{aligned} \quad (3.22)$$

Proof. Please refer to [75]. ■

Based on the above theorem, two transformed problems and original proposed problems have the same optimal solution. Therefore, we can find solutions via solving the transformed problem.

It is worthy to point out that it is still challenging to solve these two problems directly. Particularly the time switching coefficient α and power splitting coefficient ρ in the objective function result in the problem being not convex. To tackle this difficulty, we apply alternative approaches and obtain the optimum solution of one parameter while fixing the others. After all possible optimum value of energy efficiency are obtained, we select the best performance with its corresponding α and ρ . It can be confirmed that $\frac{\partial^2(C^{TS}-q_1^*E_c^{TS})}{\partial^2 P_s} < 0$ and $\frac{\partial^2(C^{PS}-q_2^*E_c^{PS})}{\partial^2 P_s} < 0$. Therefore, the two transformed problems are convex and can be solved by its Lagrange dual problem due to the strong duality existing in it.

The Lagrange functions of (3.20) and (3.21) are given by

$$\begin{aligned}
L(\beta, \lambda, \mu, P_s, \alpha) &= C^{TS} - q_1^*E_c^{TS} - \beta(P_s - P_s^{max}) \\
&\quad - \lambda(P_r^{min} - P_r) - \mu(C^{min} - C^{TS}),
\end{aligned} \tag{3.23}$$

and

$$\begin{aligned}
L(\beta, \lambda, \mu, P_s, \rho) &= C^{PS} - q_2^*E_c^{PS} - \beta(P_s - P_s^{max}) \\
&\quad - \lambda(P_r^{min} - P_r) - \mu(C^{min} - C^{PS}),
\end{aligned} \tag{3.24}$$

respectively, where $\beta \geq 0$, $\lambda \geq 0$ and $\mu \geq 0$ are the Lagrange multipliers

corresponding constraints C1, C2 and C3 in the problems in (3.20) and (3.21). The

dual problems can be expressed by

$$\min_{\beta, \lambda, \mu \geq 0} \max_{P_s, \alpha} L(\beta, \lambda, \mu, P_s, \alpha), \quad (3.25)$$

and

$$\min_{\beta, \lambda, \mu \geq 0} \max_{P_s, \rho} L(\beta, \lambda, \mu, P_s, \rho), \quad (3.26)$$

respectively. The dual problems are solved by updating solutions of the transmitted power with Lagrange multipliers.

According to KKT conditions with $\frac{\partial C^{TS} - q_1^* E_c^{TS}}{\partial P_s} = 0$, the optimum value of P_s in

the cooperative network with the time switching relaying protocol can be obtained as

$$P_s = \left[\frac{(1 + \mu)(1 - \alpha)}{2 \ln 2 \left(\beta + q_1 \alpha - \lambda \frac{2\eta(|h|^2 + \sigma_r^2)\alpha}{d_1^m(1 - \alpha)} \right)} - \frac{d_1^m \sigma_r^2}{|h|^2} \right]^+, \quad (3.27)$$

or

$$P_s = \left[\frac{(1 + \mu)(1 - \alpha)}{2 \ln 2 \left(\beta + q_1 \alpha - \lambda \frac{2\eta(|h|^2 + \sigma_r^2)\alpha}{d_1^m(1 - \alpha)} \right)} - \frac{d_1^m d_2^m (1 - \alpha) \sigma_d^2}{2\eta(|h|^2 + \sigma_r^2)|g|^2 \alpha} \right]^+, \quad (3.28)$$

There are two formulas because that different selection of α leads to use different formulas to calculate the channel capacity in the DF protocol. Specifically, if $C_{SR}^{TS} < C_{RD}^{TS}$, the optimum value of transmitted power is calculated by (3.27). If not, the

optimum value of transmitted power is calculated by (3.28). By setting $\frac{\partial C^{PS} - q_2^* E_c^{PS}}{\partial P_s} =$

0, the value of P_s in the cooperative network with the power splitting relaying protocol can be obtained by the following equations.

$$P_s = \left[\frac{(1 + \mu)}{2 \ln 2 \left(\beta + \frac{1}{2} q_2 - \lambda \frac{\eta \rho (|h|^2 + \sigma_r^2)}{d_1^m} \right)} - \frac{d_1^m \sigma_r^2}{(1 - \rho)(|h|^2 + \sigma_r^2)} \right]^+, \quad (3.29)$$

or

$$P_s = \left[\frac{(1 + \mu)}{2 \ln 2 \left(\beta + \frac{1}{2} q_2 - \lambda \frac{\eta \rho (|h|^2 + \sigma_r^2)}{d_1^m} \right)} - \frac{d_1^m d_2^m \sigma_d^2}{\eta \rho (|h|^2 + \sigma_r^2) |g|^2} \right]^+, \quad (3.30)$$

If $C_{SR}^{PS} < C_{RD}^{PS}$, the optimum value of transmitted power is calculated by (3.29). If not,

the optimum value of transmitted power is calculated by (3.30).

Then, the gradient method is employed in the iteration algorithm to update β , λ

and μ , which are given by

$$\beta(n + 1) = [\beta(n) - \psi_\beta(P_s^{max} - P_s)]^+, \quad (3.31)$$

$$\lambda(n + 1) = [\lambda(n) - \psi_\lambda(P_r - P_r^{min})]^+, \quad (3.32)$$

$$\mu(n + 1) = [\mu(n) - \psi_\mu(C^{TS} \text{ or } C^{PS} - C^{min})]^+, \quad (3.33)$$

where ψ_β , ψ_λ and ψ_μ are positive step sizes. n is the iteration index. With these

updated Lagrange multipliers and fixed α or ρ , the optimum energy efficiency can

be obtained. Then we use another choice of α or ρ until all possible optimum energy efficiency are obtained. The algorithm is proposed as follows

Table 3.1: Energy-Efficient Optimization Iteration Algorithm

<p>Outer layer algorithm:</p> <ol style="list-style-type: none"> 1. Initialize the energy harvesting coefficient α or ρ, then perform the inner layer algorithm. 2. Choose another value of α or ρ to perform the inner layer algorithm until all optimal energy efficiency solutions are obtained. Then the best performance is the optimal solution. <p>Inner layer algorithm:</p> <ol style="list-style-type: none"> 1. Initialize the q^*, Lagrange multipliers β, λ and μ, the maximum tolerance ϵ. 2. Calculate P_s in one of (3.27) to (3.30). 3. Use (3.31) to (3.33) to update the β, λ and μ in the iteration procedure. 4. If $C - q^*E_c > \epsilon$, then set $q^* = \frac{C}{E_c}$. And repeat step 2 to 3, if $C - q^*E_c < \epsilon$, the optimum P_s^* and q^* are obtained with the selective α or ρ.
--

From the proposed algorithm, transformed parametric problems can be solved by the Lagrange multiplier method. According to [75], the algorithm will always converge if the optimization problem with the objective function in subtractive form can be solved. The convergence of the optimum q^* in parametric problems is guaranteed and please refer to appendix for the proof.

Proof. Please refer to Appendix. ■

3.6 Numerical Results

In this section, simulation results are provided to evaluate the performance of the proposed energy-efficient optimization algorithm. The distance from the source to the relay and the relay to the destination are 1.5 m with the path loss exponent $m = 2$.

The antenna noise variance and conversion noise variance are equal to 0.001, i.e.

$\sigma_r^2 = \sigma_d^2 = 0.001$. The energy harvesting coefficient is set as 1. The circuit-consumed power at the source, the relay, and the destination is all set to 0.1 Joule/sec. The

maximum transmitted power is 1 Joule/sec, the minimum harvested power is 0.5 Joule/sec, and the minimum required channel capacity is 1 bits/sec/Hz. The mean values of the exponential random variables $|h|^2$ and $|g|^2$ are set to 1. Simulation results were averaged over 1000 independent trials. In Fig. (3.2), the convergence of the proposed algorithm for the energy-efficient maximization problem in the cooperative network with the time switching relaying protocol and power splitting relaying protocol is shown, where the energy efficiency for the case without optimization is also provided as a benchmark. As can be seen from the figure, the proposed algorithm with the time switching relaying protocol and the power splitting relaying protocol converges within five iterations. The concavity of problems can be guaranteed. Since the proposed algorithm always converges, the optimum energy efficiency can be obtained by using the proposed algorithm. The Fig. (3.2) also presents the performance of the algorithm for the time switching relaying and power splitting relaying protocol with the value of $\alpha = 0.3$ and $\rho = 0.5$. In this circumstance, the proposed algorithm with power splitting relaying protocol has better optimum energy efficiency. To facilitate a better performance evaluation, energy

efficiency without optimization in the time switching relaying model and power splitting relaying model are also provided. The value of energy efficiency without the proposed algorithm is obtained with the maximum allowed transmitted power. It is evident that the energy efficiency cannot outperform the proposed algorithm. The reason for this performance gain is following. The energy efficiency is the ratio of the channel capacity and the overall power consumption. The proposed algorithm maximizes the energy efficiency and its optimal solution is obtained with the suitable power. The schemes without optimization use the maximal power to transmit information to achieve a larger channel capacity, but from the energy efficiency's perspective, the system consumes more power to decrease the energy efficiency. The proposed algorithm guarantees that better energy efficiency can be achieved.

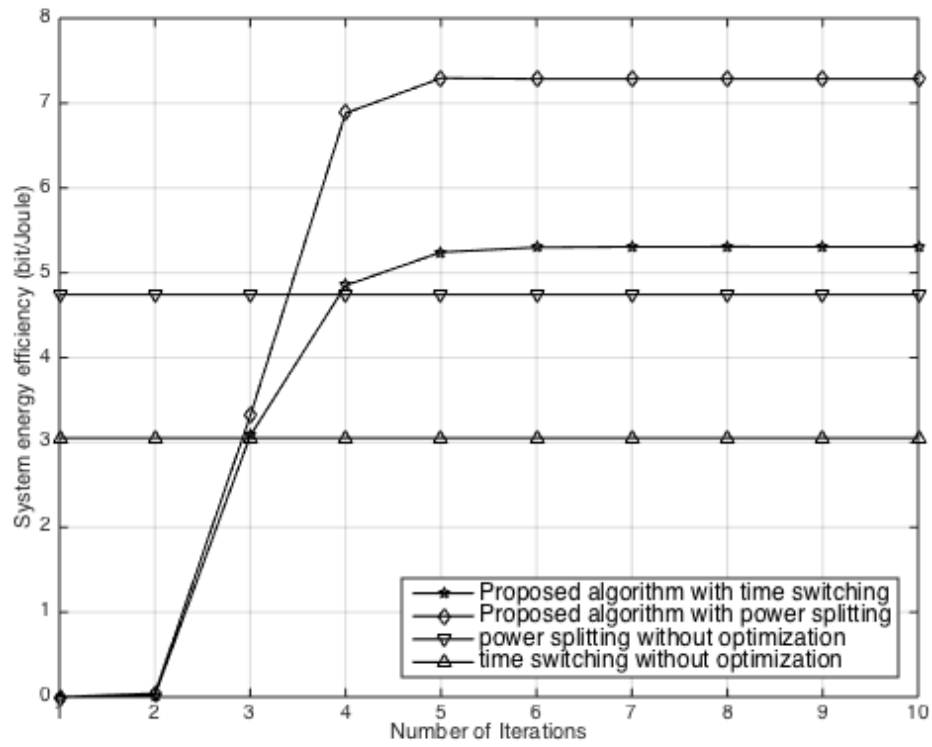

Figure 3.2: The performance of proposed algorithm with the time switching relaying protocol and the power splitting relaying protocol.

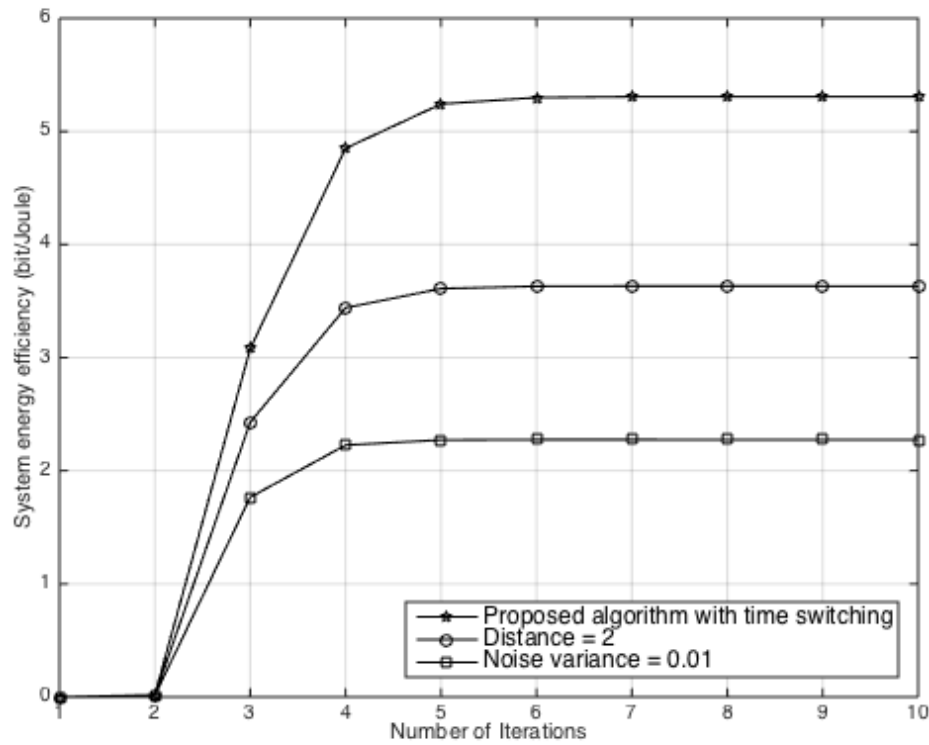

Figure 3.3: Energy efficiency optimization for the time switching relaying protocol with different parameters.

Fig. (3.3) and Fig. (3.4) illustrate performances of system energy-efficient maximization with various noise variances and distances based on the time switching relaying and power splitting relaying protocol. As can be seen from pictures, the energy efficiency is deteriorated by the increasing noise variances and distances. The reason is that when noise variances and distances increase, the channel capacity will reduce and then lead to the decrease of energy efficiency.

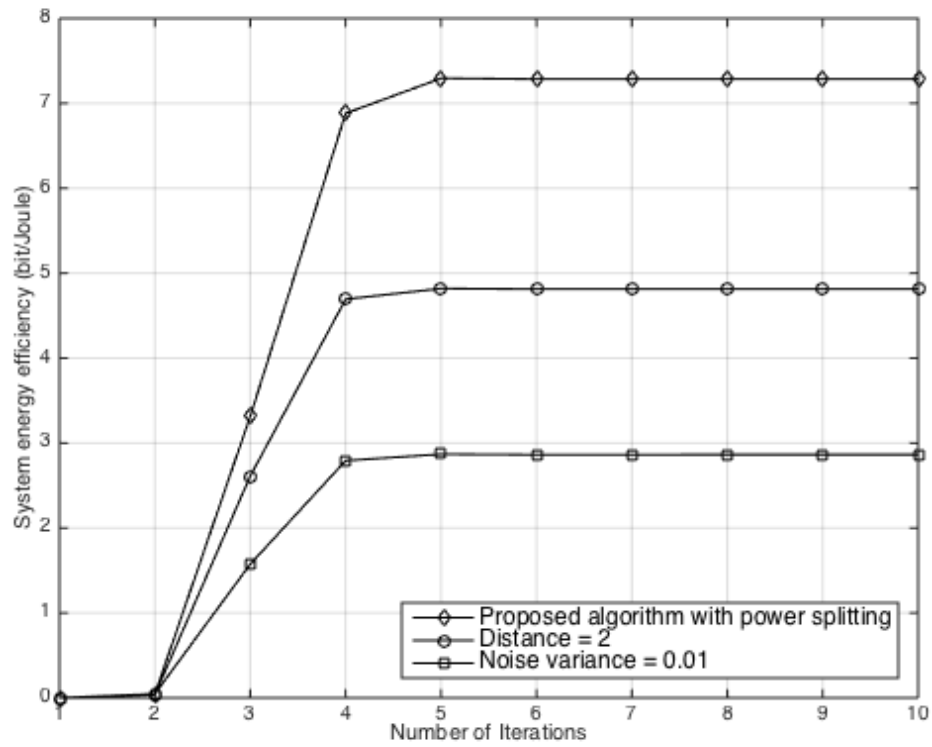

Figure 3.4: Energy efficiency optimization for the power splitting relaying protocol

with different parameters.

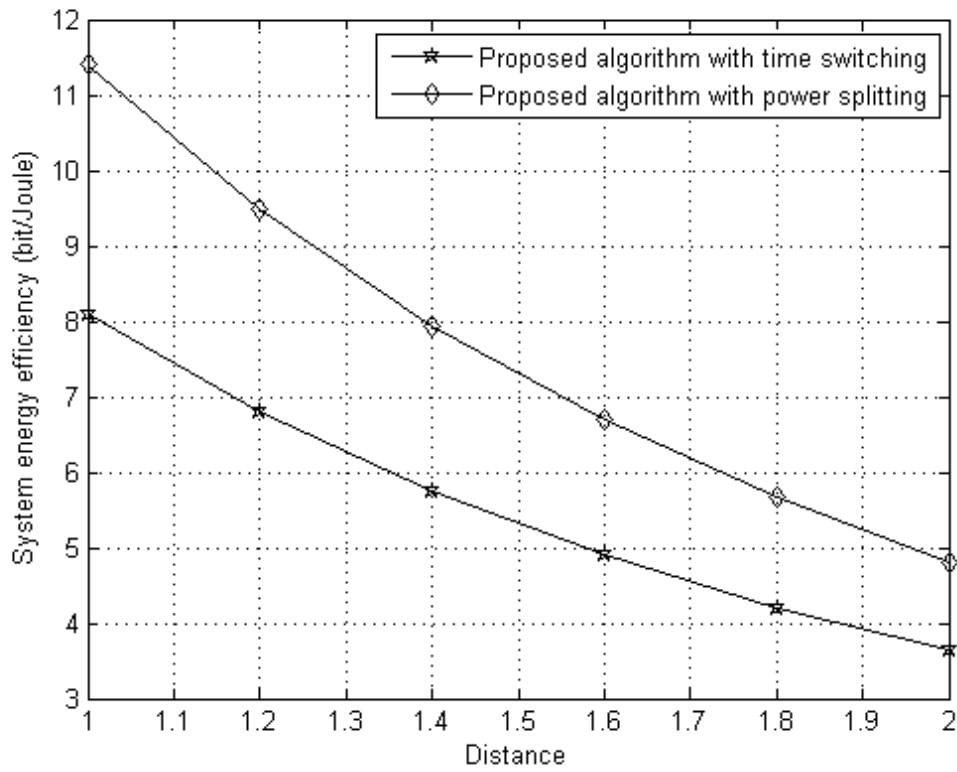

Figure 3.5: Energy efficiency for energy harvesting protocols versus distances.

In Fig. (3.5), the system performances with two energy harvesting protocols versus distances are given. It can be seen that the energy efficiency is decreased when the distance becomes larger. In the wireless energy harvesting network, the increase of distance results in that harvesting energy becomes more difficult. If the relay node cannot harvest enough energy, then it does not have enough power to achieve the maximal the energy efficiency.

3.7 Chapter Summary

This chapter proposed feasible solutions for the maximization of energy efficiency in cooperative wireless networks based on the time switching relaying protocol and power splitting relaying protocol. The original problem is first transformed to the convex form by using nonlinear fractional programming and then is solved by applying the Lagrange multiplier method. Simulation results confirm the energy efficiency of the proposed algorithm in the considered model. The trade-off between energy efficiency and system parameters is also analyzed in the section of numerical result.

Chapter 4

Secure Communication in Cooperative Networks with Wireless Information and Power Transfer

4.1 Introduction

For the communication network, the issue of security for wireless information and power transfer is also important, where the passive eavesdropper can potentially intercept the source transmission due to the openness of wireless channels. There are many existing works regarding the general physical layer security [76], [77], [78]. In [76], the overhearing channel can be considered as a degraded one to receive the information and multiple antennas were used in secure communication systems, where the secrecy capacity is optimized by carefully designing beamforming. Based on the study for secrecy rates in SISO fading channels [79], researchers optimized the secure problem in MISO and MIMO systems [80], [81]. Since the wireless relaying network can enhance the spectrum efficiency and the physical layer security, the secure

optimization in cooperative networks has been studied in [82]. The cooperative beamforming optimization problem was studied in [83], [84], [85], in which relays use AF and DF strategies to transmit confidential messages to legitimate receivers.

In this chapter, we study the secrecy rate maximization in the AF wireless cooperative network with an energy harvesting relay. The authors in [86], [52], [87] studied the secure issue with simultaneous wireless information and power transfer for MISO broadcast channels. The secure beamforming at the relay studied in [88] proposed an iterative algorithm to solve the optimization problem. Motivated by these works above, we consider the secure issue in a cooperative wireless network in which the energy harvesting relay harvests energy from RF signals transmitted by the source and then assist the source in delivering its information to the destination. We formulate the problem of maximizing the secrecy rate subject to the transmitted power constraint based on the two different energy harvesting strategies, i.e. the power splitting relaying protocol and time switching relaying protocol. We solve these problems by using the SDP relaxation approach and 1-D optimization over the coefficients of energy harvesting protocols.

4.2 System Model

Consider a wireless cooperative relaying network consisting of one source node, one relay node, one destination node and one eavesdropper node. Except that the relay node which has N antennas, all other nodes are equipped with a single antenna. We assume that there is no direct link between the source, and the eavesdropper/destination, i.e. the N -antenna energy harvesting relay transmits the source data to the destination node while preventing the eavesdropper from intercepting source messages. The perfect channel state information is assumed available at the relay node. It may be feasible for the scenario that the eavesdropper is also a user in the network but is malicious to overhear the messages from other users. The considered network is demonstrated in Fig. (4.1).

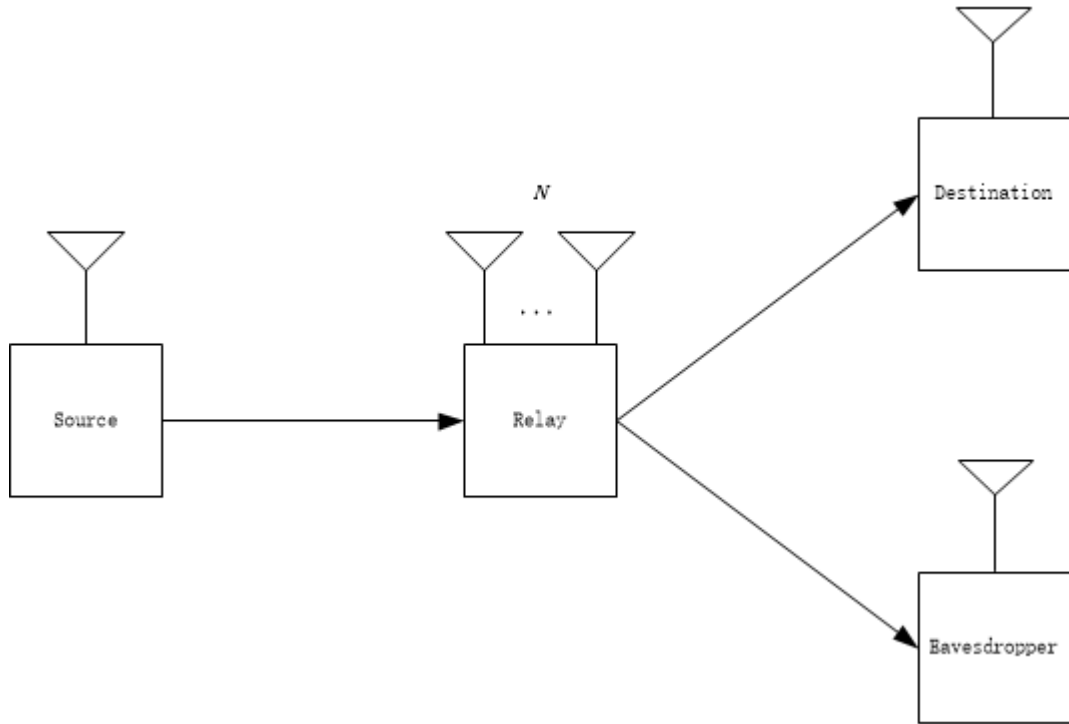

Figure 4.1: System model for energy harvesting cooperative network with one source-destination pair and one eavesdropper.

The energy harvesting relay can harvest energy from RF signals transmitted by the source node and utilize the energy as the transmitted power to forward the source information. In this chapter, we assume the relay node has an initial power and further collects power from the source node to relay the information; therefore the energy harvesting technique can further improve the performance [89]. The battery capacity of the energy harvesting relay is assumed as infinite. The AF scheme is considered in the cooperative network. The two relaying protocols for energy harvesting are

considered in the chapter. A detailed analysis based on the time switching relaying protocol and the power splitting relaying protocol are given in the following two sections, respectively. It is assumed that the power consumed in the transmission circuit at the relay is negligible when it is compared to the transmission power used for sending the source data to the destination.

4.3 Secrecy Rate Maximization based on Power Splitting Relaying Protocol

In this section, we study secrecy rate maximization based on the power splitting relaying protocol. The transmission scheme with power splitting relaying protocol and the corresponding optimization problem are given as follows.

4.3.1 System Transmission Model and Problem Statement

The energy harvesting relay harvests energy and detects the transmitted signal from

the source in the first phase. The received signal at the relay can be express as

$$\mathbf{y}_r = \sqrt{P_s} \mathbf{h}_r s + \mathbf{n}_r, \quad (4.1)$$

where P_s is the transmitted power at the source node, $\mathbf{h}_r \in \mathbb{C}^{N \times 1}$ denotes the channel vector between the source node and the relay node, s is the transmitted data from the source node with $\mathcal{E}(|s|^2) = 1$, \mathbf{n}_r is the additive complex Gaussian noise vector at the relay node following $\mathcal{CN}(\mathbf{0}, \sigma_r^2 \mathbf{I}_N)$.

Because the power splitting protocol is applied at the relay node, the observation is split into two streams: one is for the energy harvesting, and the other one is for information decoding, respectively. It results in the following received signal for the information decoder.

$$\mathbf{y}_r^{ID} = \sqrt{\rho P_s} \mathbf{h}_r s + \sqrt{\rho} \mathbf{n}_r + \mathbf{n}_c, \quad (4.2)$$

where \mathbf{n}_c is the additive complex Gaussian noise vector due to the RF to baseband conversion following $\mathcal{CN}(\mathbf{0}, \sigma_c^2 \mathbf{I}_N)$. At the same time, the energy harvesting relay harvests energy from the source, the signal for energy harvesting is given by

$$\mathbf{y}_r^{EH} = \sqrt{(1 - \rho) P_s} \mathbf{h}_r s + \sqrt{(1 - \rho)} \mathbf{n}_r, \quad (4.3)$$

Therefore, the amount of the harvested energy is

$$E = \frac{\eta(1 - \rho)(P_s \|\mathbf{h}_r\|^2 + \sigma_r^2)T}{2}, \quad (4.4)$$

where η is the energy conversion efficiency coefficient at the relay. The relay node has an initial energy E_r^{ini} and further harvests energy. Therefore, after the relay is wirelessly powered by the source with the power splitting relaying protocol, the total available transmit power at the relay node is expressed as

$$P_r^{max} = \eta(1 - \rho)(P_s \|\mathbf{h}_r\|^2 + \sigma_r^2) + E_r^{ini}, \quad (4.5)$$

Since the energy harvesting relay is operated with the AF protocol, upon receiving the signal, the relay processes the signal by the relay precoding. The signal transmitted at the relay node is given by

$$\mathbf{x}_r = \sqrt{\rho P_s} \mathbf{W} \mathbf{h}_{rS} + \sqrt{\rho} \mathbf{W} \mathbf{n}_r + \mathbf{W} \mathbf{n}_c, \quad (4.6)$$

where $\mathbf{W} \in \mathbb{C}^{N \times N}$ is the precoding matrix, it contains the amplification factor and also the transmitted power. The power of \mathbf{x}_r at the relay node is

$$P_r = \rho P_s \|\mathbf{W} \mathbf{h}_r\|^2 + \rho \sigma_r^2 \|\mathbf{W}\|^2 + \sigma_c^2 \|\mathbf{W}\|^2, \quad (4.7)$$

Then the received signal at the destination node in the second phase is given by

$$y_d = \sqrt{\rho P_s} \mathbf{h}_d^T \mathbf{W} \mathbf{h}_{rS} + \sqrt{\rho} \mathbf{h}_d^T \mathbf{W} \mathbf{n}_r + \mathbf{h}_d^T \mathbf{W} \mathbf{n}_c + n_d, \quad (4.8)$$

where $\mathbf{h}_d \in \mathbb{C}^{N \times 1}$ denotes the channel vector between the relay node and the

destination node and n_d is the additive Gaussian noise at the destination following $\mathcal{CN}(0, \sigma_d^2)$. Similarly, the received signal at the eavesdropper can be written as

$$y_e = \sqrt{\rho P_s} \mathbf{h}_e^T \mathbf{W} \mathbf{h}_r s + \sqrt{\rho} \mathbf{h}_e^T \mathbf{W} \mathbf{n}_r + \mathbf{h}_e^T \mathbf{W} \mathbf{n}_c + n_e, \quad (4.9)$$

where $\mathbf{h}_e \in \mathbb{C}^{N \times 1}$ denotes the channel vector between the relay node and the destination node, and n_e is the additive Gaussian noise at the destination following $\mathcal{CN}(0, \sigma_e^2)$.

According to the aforementioned signal model, the received SNRs at the destination node and the eavesdropper node are

$$SNR_d = \frac{\rho P_s |\mathbf{h}_d^T \mathbf{W} \mathbf{h}_r|^2}{\rho \sigma_r^2 \|\mathbf{h}_d^T \mathbf{W}\|^2 + \sigma_c^2 \|\mathbf{h}_d^T \mathbf{W}\|^2 + \sigma_d^2}, \quad (4.10)$$

and

$$SNR_e = \frac{\rho P_s |\mathbf{h}_e^T \mathbf{W} \mathbf{h}_r|^2}{\rho \sigma_r^2 \|\mathbf{h}_e^T \mathbf{W}\|^2 + \sigma_c^2 \|\mathbf{h}_e^T \mathbf{W}\|^2 + \sigma_e^2}, \quad (4.11)$$

respectively.

The achievable secrecy rate can be presented as

$$R_s = \left[\frac{1}{2} \log_2(1 + SNR_d) - \frac{1}{2} \log_2(1 + SNR_e) \right]^+, \quad (4.12)$$

In this chapter, we formulate the problem for maximizing the secrecy rate subject to the transmitted power constraint at the relay node via jointly optimizing relay

precoding and the power splitting coefficient. Particularly, the addressed optimization problem is formulated as follows

$$\begin{aligned}
 & \max_{W, \rho} R_s \\
 & s. t. C1: P_r \leq P_r^{max}, \\
 & C2: 0 \leq \rho \leq 1.
 \end{aligned} \tag{4.13}$$

It is obvious that the problem stated above is not a standard convex problem because the objective function is non-concave and the power splitting coefficient results in the problem being not convex. In the next subsection, we find the solution to this problem.

It is noted that in the $C1$, the transmitted power at the relay node may not use the total available power from the energy harvesting and this may results in that there will be the leftover of energy at the relay node stored for the next block time. However, in the simulation, the relay node always uses the total available at the relay node to maximize the secrecy rate, so the above concern does not exist in this optimization problem.

4.3.2 The Optimal Solution

In this subsection, we proposed an optimal solution based on SDP relaxation. Firstly we introduce a new variable γ_e to represent the predefined threshold for the eavesdropper's SNR. γ_e denotes the maximum tolerable SINR at the eavesdropper, which is practically much less than the SINR at the desired destination node to ensure the secure communication. After we introduce γ_e , if the transformed problem is solvable, it is guaranteed that the secrecy capacity is larger than 0. Although γ_e is not the optimization variable in our problem, the optimal solution of the transformed problem is close to the original problem if the value of γ_e is suitable. The original problem is reformulated as follows:

$$\begin{aligned} & \max_{W, \rho} SNR_d \\ & s. t. C1: SNR_e \leq \gamma_e, \\ & C2: P_r \leq P_r^{max}, \\ & C3: 0 \leq \rho \leq 1. \end{aligned} \tag{4.14}$$

The new obtained problem is still not a convex problem. We further transform the

objective function as follows:

$$\begin{aligned} SNR_d &= \frac{\rho P_s |\mathbf{h}_d^T \mathbf{W} \mathbf{h}_r|^2}{\rho \sigma_r^2 \|\mathbf{h}_d^T \mathbf{W}\|^2 + \sigma_c^2 \|\mathbf{h}_d^T \mathbf{W}\|^2 + \sigma_d^2}, \\ &= \frac{\mathbf{w}^H \mathbf{Q}_{a1} \mathbf{w}}{\mathbf{w}^H \mathbf{Q}_{a2} \mathbf{w} + \sigma_d^2}, \end{aligned} \quad (4.15)$$

where $\mathbf{w} = \text{vec}(\mathbf{W})$ and

$$\mathbf{Q}_{a1} = \rho P_s (\mathbf{h}_r \mathbf{h}_r^H)^T \otimes (\mathbf{h}_d^* \mathbf{h}_d^T), \quad (4.16)$$

$$\mathbf{Q}_{a2} = (\rho \sigma_r^2 \mathbf{I}_N + \sigma_c^2 \mathbf{I}_N) \otimes (\mathbf{h}_d^* \mathbf{h}_d^T), \quad (4.17)$$

The above transform is obtained by using the rule as follows [90]

$$\text{Tr}(\mathbf{A}\mathbf{B}\mathbf{C}\mathbf{D}) = (\text{vec}(\mathbf{D}^T))^T (\mathbf{C}^T \otimes \mathbf{A}) \text{vec}(\mathbf{B}), \quad (4.18)$$

Then we transform the SNR of the eavesdropper constraint as

$$\begin{aligned} SNR_e &= \frac{\rho P_s |\mathbf{h}_e^T \mathbf{W} \mathbf{h}_r|^2}{\rho \sigma_r^2 \|\mathbf{h}_e^T \mathbf{W}\|^2 + \sigma_c^2 \|\mathbf{h}_e^T \mathbf{W}\|^2 + \sigma_e^2}, \\ &= \frac{\mathbf{w}^H \mathbf{Q}_{b1} \mathbf{w}}{\mathbf{w}^H \mathbf{Q}_{b2} \mathbf{w} + \sigma_e^2}, \end{aligned} \quad (4.19)$$

where

$$\mathbf{Q}_{b1} = \rho P_s (\mathbf{h}_r \mathbf{h}_r^H)^T \otimes (\mathbf{h}_e^* \mathbf{h}_e^T), \quad (4.20)$$

$$\mathbf{Q}_{b2} = (\rho \sigma_r^2 \mathbf{I}_N + \sigma_c^2 \mathbf{I}_N) \otimes (\mathbf{h}_e^* \mathbf{h}_e^T), \quad (4.21)$$

The transmitted power constraint can be rewritten as

$$P_r = \rho P_s \|\mathbf{W} \mathbf{h}_r\|^2 + \rho \sigma_r^2 \|\mathbf{W}\|^2 + \sigma_c^2 \|\mathbf{W}\|^2, \quad (4.22)$$

$$= \mathbf{w}^H \mathbf{Q}_c \mathbf{w},$$

where

$$\mathbf{Q}_c = (\rho P_s \mathbf{h}_r \mathbf{h}_r^H + \rho \sigma_r^2 \mathbf{I}_N + \sigma_c^2 \mathbf{I}_N) \otimes \mathbf{I}_N, \quad (4.23)$$

Define a new variable $\mathbf{X} = \mathbf{w} \mathbf{w}^H$, the optimization problem can be reformulated

as

$$\begin{aligned} & \max_{\mathbf{X} \succeq \mathbf{0}, \rho} \frac{\text{Tr}(\mathbf{Q}_{a1} \mathbf{X})}{\text{Tr}(\mathbf{Q}_{a2} \mathbf{X}) + \sigma_d^2} \\ & \text{s. t. C1: } \frac{\text{Tr}(\mathbf{Q}_{b1} \mathbf{X})}{\text{Tr}(\mathbf{Q}_{b2} \mathbf{X}) + \sigma_e^2} \leq \gamma_e, \\ & \text{C2: } \text{Tr}(\mathbf{Q}_c \mathbf{X}) \leq P_r^{\max}, \\ & \text{C3: } 0 \leq \rho \leq 1, \\ & \text{C4: } \text{Rank}(\mathbf{X}) = 1. \end{aligned} \quad (4.24)$$

It can be seen that the rank-one constraint makes the problem still difficult to solve.

Therefore, we drop the rank-one constraint and a SDP problem can be obtained as

$$\begin{aligned} & \max_{\mathbf{X} \succeq \mathbf{0}, \rho} \frac{\text{Tr}(\mathbf{Q}_{a1} \mathbf{X})}{\text{Tr}(\mathbf{Q}_{a2} \mathbf{X}) + \sigma_d^2} \\ & \text{s. t. C1: } \text{Tr}(\mathbf{Q}_{b12} \mathbf{X}) \leq \sigma_e^2, \\ & \text{C2: } \text{Tr}(\mathbf{Q}_c \mathbf{X}) \leq P_r^{\max}, \\ & \text{C3: } 0 \leq \rho \leq 1. \end{aligned} \quad (4.25)$$

where $\mathbf{Q}_{b12} = \frac{1}{\gamma_e} \mathbf{Q}_{b1} - \mathbf{Q}_{b2}$. It is worthy to point out that it is still challenging to solve this problem directly, mainly due to the power splitting coefficient in the problem, which renders the joint optimization problem unsolvable. To tackle this difficulty, we perform 1-D optimization over the power splitting coefficient. Then we can select the best performance among those possible choices of the power splitting coefficient. If the value of ρ is set, the problem can be treated as a quasi-convex SDP problem. Instead of employing the bisection search approach, we use the Charnes-Cooper transformation [91] to solve it. Specifically, we define a new variable

$t = \frac{1}{\text{Tr}(\mathbf{Q}_{a2}\mathbf{X}) + \sigma_d^2}$ and let $\tilde{\mathbf{X}} = t\mathbf{X}$. The problem can be recast as follows

$$\begin{aligned}
& \max_{\tilde{\mathbf{X}} \succeq \mathbf{0}, t} \text{Tr}(\mathbf{Q}_{a1}\tilde{\mathbf{X}}) \\
& \text{s. t. C1: } \text{Tr}(\mathbf{Q}_{a2}\tilde{\mathbf{X}}) + t\sigma_d^2 = 1, \\
& \quad \text{C2: } \text{Tr}(\mathbf{Q}_{b12}\tilde{\mathbf{X}}) \leq t\sigma_e^2, \\
& \quad \text{C3: } \text{Tr}(\mathbf{Q}_c\tilde{\mathbf{X}}) \leq tP_r^{max}. \tag{4.26}
\end{aligned}$$

Then the problem is a standard SDP problem, and one can efficiently find its global optimal solution via available solvers [92]. The optimal solution is supposed as $\tilde{\mathbf{X}}^*$, t^* . Then the optimal solution of \mathbf{X} denoted by \mathbf{X}^* is obtained by $\mathbf{X}^* = \frac{\tilde{\mathbf{X}}^*}{t^*}$. If

the rank of $\tilde{\mathbf{X}}^*$ is one, \mathbf{w} is exactly calculated via the eigenvalue decomposition.

Otherwise, we can employ the following theorem which is obtained from the result in

[93] to obtain the rank-one solution.

Theorem 1. *For a matrix $\tilde{\mathbf{X}}^*$ which has a higher rank, the rank-one solution can be acquired via the follow procedure.*

Table 4.1: SBP rank reduction procedure

1. Decompose $\tilde{\mathbf{X}}^*$ as $\tilde{\mathbf{X}}^* = \mathbf{V}\mathbf{V}^H$ with $\mathbf{V} \in \mathbb{C}^{N^2 \times r}$, where r is the rank of $\tilde{\mathbf{X}}^*$.
2. Find a nonzero $r \times r$ Hermitian matrix \mathbf{M} to satisfy the equations as follows
 $Tr(\mathbf{V}^H \mathbf{Q}_{a2} \mathbf{V} \mathbf{M}) = 0$, $Tr(\mathbf{V}^H \mathbf{Q}_{b12} \mathbf{V} \mathbf{M}) = 0$ and $Tr(\mathbf{V}^H \mathbf{Q}_c \mathbf{V} \mathbf{M}) = 0$.
3. Evaluate all eigenvalues $\lambda_1, \lambda_2 \dots \lambda_r$ for matrix \mathbf{M} and define $|\lambda| = \max\{|\lambda_1|, |\lambda_2| \dots |\lambda_r|\}$, where $|\lambda|$ represents the modulus of λ .
4. Update matrix $\tilde{\mathbf{X}}^* = \mathbf{V}(\mathbf{I}_r - \frac{1}{\lambda} \mathbf{M})\mathbf{V}^H$. If $\tilde{\mathbf{X}}^*$ still has the higher rank, we repeat the step 1-3 until the rank of $\tilde{\mathbf{X}}^*$ is one.

Proof. The proof steps are similar to the ones in [93], [94]. Since there are three linear

equations in Step 2, we can always find a nonzero solution \mathbf{M} if $r^2 \geq 3$. It is can be found that the rank of $\tilde{\mathbf{X}}^*$ is reduced at least one by performing one iteration. And the updated $\tilde{\mathbf{X}}^*$ in step 4 satisfies equations in step 2, which is also a solution for the SDP problem, i.e. the updated $\tilde{\mathbf{X}}^*$ can achieve the same value of the objective function for our transformed problem but with the lower rank. We can finally acquire a rank-one solution by repeating the procedure. The proof is completed. ■

Remark 1. In step 2 of Theorem 1, we need to solve an undetermined system of linear equations to find \mathbf{M} . There are three equations and r^2 real-valued unknowns. If $r^2 \geq 3$, then it can be found a nonzero solution for linear equations. We can rewrite the system of linear equations into the form $\mathbf{A}\mathbf{x} = 0$, where $\mathbf{A} \in \mathbb{R}^{3 \times r^2}$ and $\mathbf{x} \in \mathbb{R}^{r^2}$. The matrix \mathbf{A} is the combination of the matrix $\mathbf{V}^H \mathbf{Q}_{a2} \mathbf{V}$, $\mathbf{V}^H \mathbf{Q}_{b12} \mathbf{V}$ and $\mathbf{V}^H \mathbf{Q}_c \mathbf{V}$. Then finding a nonzero \mathbf{x} is equal to finding the null space of \mathbf{A} . Recall that $\mathbf{M} \in \mathbb{R}^{r \times r}$, after reshaping \mathbf{x} , \mathbf{M} is obtained.

Remark 2. The rank of $\tilde{\mathbf{X}}^*$ will be reduced at least one by performing Theorem 1 one

time. The number of iterations depends on the initial rank of $\tilde{\mathbf{X}}^*$. For example, if the initial rank of $\tilde{\mathbf{X}}^*$ is 9, at worst we need to perform Theorem 1 eight times.

4.4 Secrecy Rate Maximization based on Time Switching

Relaying Protocol

In this section, we study the secrecy rate maximization problem on the basis of time switching relaying protocol. The transmission model with the time switching relaying protocol and the corresponding optimization problem are given as follows.

4.4.1 System Transmission Model and Problem Statement

The received signal at the relay can be expressed as follows

$$\mathbf{y}_r = \sqrt{P_s} \mathbf{h}_r s + \mathbf{n}_r + \mathbf{n}_c, \quad (4.27)$$

where P_s , \mathbf{h}_r , s , \mathbf{n}_r and \mathbf{n}_c have the same definition as previously.

The relay harvests energy from RF signals sent by the source for α time, and the

amount of the harvested energy is given by

$$E = \eta\alpha(P_s\|\mathbf{h}_r\|^2 + \sigma_r^2)T, \quad (4.28)$$

The total available transmit power at the relay is then expressed as follows

$$P_r^{max} = \frac{2\eta\alpha(P_s\|\mathbf{h}_r\|^2 + \sigma_r^2)}{1 - \alpha} + E_r^{ini}, \quad (4.29)$$

Since the energy harvesting relay is operated with the AF protocol, the signal transmitted by the relay node can be written as follows

$$\mathbf{x}_r = \sqrt{P_s}\mathbf{W}\mathbf{h}_r s + \mathbf{W}\mathbf{n}_r + \mathbf{W}\mathbf{n}_c, \quad (4.30)$$

The relay transmission power is given by

$$P_r = P_s\|\mathbf{W}\mathbf{h}_r\|^2 + \sigma_r^2\|\mathbf{W}\|^2 + \sigma_c^2\|\mathbf{W}\|^2, \quad (4.31)$$

Then the received signal at the destination node is given by

$$y_d = \sqrt{P_s}\mathbf{h}_d^T\mathbf{W}\mathbf{h}_r s + \mathbf{h}_d^T\mathbf{W}\mathbf{n}_r + \mathbf{h}_d^T\mathbf{W}\mathbf{n}_c + n_d, \quad (4.32)$$

Similarly, the received signal at the eavesdropper can be written as follows

$$y_e = \sqrt{P_s}\mathbf{h}_e^T\mathbf{W}\mathbf{h}_r s + \mathbf{h}_e^T\mathbf{W}\mathbf{n}_r + \mathbf{h}_e^T\mathbf{W}\mathbf{n}_c + n_e, \quad (4.33)$$

According to the described signal model, the received SNRs at the destination node and the eavesdropper node are

$$SNR_d = \frac{P_s|\mathbf{h}_d^T\mathbf{W}\mathbf{h}_r|^2}{\sigma_r^2\|\mathbf{h}_d^T\mathbf{W}\|^2 + \sigma_c^2\|\mathbf{h}_d^T\mathbf{W}\|^2 + \sigma_d^2}, \quad (4.34)$$

and

$$SNR_e = \frac{P_s |\mathbf{h}_e^T \mathbf{W} \mathbf{h}_r|^2}{\sigma_r^2 \|\mathbf{h}_e^T \mathbf{W}\|^2 + \sigma_c^2 \|\mathbf{h}_e^T \mathbf{W}\|^2 + \sigma_e^2}, \quad (4.35)$$

respectively. The achievable secrecy rate with the time switching relaying protocol can be expressed as

$$R_s = \left| \frac{1-\alpha}{2} \log_2(1 + SNR_d) - \frac{1-\alpha}{2} \log_2(1 + SNR_e) \right|^+, \quad (4.36)$$

We formulate the problem of maximizing the secrecy rate subject to the transmitted power constraint at the relay node, via jointly optimizing relay precoding and the time switching coefficient. The optimization problem is formulated as follows

$$\begin{aligned} & \max_{\mathbf{W}, \alpha} R_s \\ & s. t. C1: P_r \leq P_r^{max}, \\ & C2: 0 \leq \alpha \leq 1. \end{aligned} \quad (4.37)$$

This problem is in a form similar to the one proposed in the previous section, and also not a standard convex problem. We can perform similar transform steps to make the problem solvable.

4.4.2. The Optimal Solution

Firstly we introduce a new variable γ_e to represent the predefined threshold for the eavesdropper's SNR and reformulate the original problem as follows

$$\begin{aligned}
 & \max_{\mathbf{W}, \alpha} SNR_d \\
 & s. t. C1: SNR_e \leq \gamma_e, \\
 & C2: P_r \leq P_r^{max}, \\
 & C3: 0 \leq \alpha \leq 1.
 \end{aligned} \tag{4.37}$$

Then we further transform the objective function as follows

$$\begin{aligned}
 SNR_d &= \frac{P_s |\mathbf{h}_d^T \mathbf{W} \mathbf{h}_r|^2}{\sigma_r^2 \|\mathbf{h}_d^T \mathbf{W}\|^2 + \sigma_c^2 \|\mathbf{h}_d^T \mathbf{W}\|^2 + \sigma_d^2}, \\
 &= \frac{\mathbf{w}^H \mathbf{Q}_{a1} \mathbf{w}}{\mathbf{w}^H \mathbf{Q}_{a2} \mathbf{w} + \sigma_d^2},
 \end{aligned} \tag{4.38}$$

where

$$\mathbf{Q}_{a1} = P_s (\mathbf{h}_r \mathbf{h}_r^H)^T \otimes (\mathbf{h}_d^* \mathbf{h}_d^T), \tag{4.39}$$

$$\mathbf{Q}_{a2} = (\sigma_r^2 \mathbf{I}_N + \sigma_c^2 \mathbf{I}_N) \otimes (\mathbf{h}_d^* \mathbf{h}_d^T), \tag{4.40}$$

The SNR of the eavesdropper constraint is given by

$$SNR_e = \frac{P_s |\mathbf{h}_e^T \mathbf{W} \mathbf{h}_r|^2}{\sigma_r^2 \|\mathbf{h}_e^T \mathbf{W}\|^2 + \sigma_c^2 \|\mathbf{h}_e^T \mathbf{W}\|^2 + \sigma_e^2}, \tag{4.41}$$

$$= \frac{\mathbf{w}^H \mathbf{Q}_{b1} \mathbf{w}}{\mathbf{w}^H \mathbf{Q}_{b2} \mathbf{w} + \sigma_e^2},$$

where

$$\mathbf{Q}_{b1} = P_s (\mathbf{h}_r \mathbf{h}_r^H)^T \otimes (\mathbf{h}_e^* \mathbf{h}_e^T), \quad (4.42)$$

$$\mathbf{Q}_{b2} = (\sigma_r^2 \mathbf{I}_N + \sigma_c^2 \mathbf{I}_N) \otimes (\mathbf{h}_e^* \mathbf{h}_e^T), \quad (4.43)$$

The transmitted power constraint can be rewritten as follows

$$\begin{aligned} P_r &= P_s \|\mathbf{W} \mathbf{h}_r\|^2 + \sigma_r^2 \|\mathbf{W}\|^2 + \sigma_c^2 \|\mathbf{W}\|^2, \\ &= \mathbf{w}^H \mathbf{Q}_c \mathbf{w}, \end{aligned} \quad (4.44)$$

where

$$\mathbf{Q}_c = (P_s \mathbf{h}_r \mathbf{h}_r^H + \sigma_r^2 \mathbf{I}_N + \sigma_c^2 \mathbf{I}_N) \otimes \mathbf{I}_N, \quad (4.45)$$

Define $\mathbf{X} = \mathbf{w} \mathbf{w}^H$, and the optimization problem can be reformulated as follows

$$\begin{aligned} &\max_{\mathbf{X} \succeq \mathbf{0}, \alpha} \frac{\text{Tr}(\mathbf{Q}_{a1} \mathbf{X})}{\text{Tr}(\mathbf{Q}_{a2} \mathbf{X}) + \sigma_d^2} \\ &s. t. C1: \frac{\text{Tr}(\mathbf{Q}_{b1} \mathbf{X})}{\text{Tr}(\mathbf{Q}_{b2} \mathbf{X}) + \sigma_e^2} \leq \gamma_e, \\ &C2: \text{Tr}(\mathbf{Q}_c \mathbf{X}) \leq P_r^{max}, \\ &C3: 0 \leq \alpha \leq 1, \\ &C4: \text{Rank}(\mathbf{X}) = 1. \end{aligned} \quad (4.46)$$

We drop the rank-one constraint and a SDP problem can be obtained as follows

$$\begin{aligned}
& \max_{\mathbf{X} \succeq \mathbf{0}, \alpha} \frac{\text{Tr}(\mathbf{Q}_{a1}\mathbf{X})}{\text{Tr}(\mathbf{Q}_{a2}\mathbf{X}) + \sigma_d^2} \\
& \text{s. t. C1: } \text{Tr}(\mathbf{Q}_{b12}\mathbf{X}) \leq \sigma_e^2, \\
& \text{C2: } \text{Tr}(\mathbf{Q}_c\mathbf{X}) \leq P_r^{\max}, \\
& \text{C3: } 0 \leq \alpha \leq 1. \tag{4.47}
\end{aligned}$$

where $\mathbf{Q}_{b12} = \frac{1}{\gamma_e} \mathbf{Q}_{b1} - \mathbf{Q}_{b2}$. The time switching coefficient is still a challenge to be optimized. We again perform 1-D optimization over the time switching coefficient. If the value of α is set, the problem can be treated as a quasi-convex SDP problem. We also use the Charnes-Cooper transformation. Define a new variable $t = \frac{1}{\text{Tr}(\mathbf{Q}_{a2}\mathbf{X}) + \sigma_d^2}$

and let $\tilde{\mathbf{X}} = t\mathbf{X}$. The problem can be recast as follows

$$\begin{aligned}
& \max_{\tilde{\mathbf{X}} \succeq \mathbf{0}, t} \text{Tr}(\mathbf{Q}_{a1}\tilde{\mathbf{X}}) \\
& \text{s. t. C1: } \text{Tr}(\mathbf{Q}_{a2}\tilde{\mathbf{X}}) + t\sigma_d^2 = 1, \\
& \text{C2: } \text{Tr}(\mathbf{Q}_{b12}\tilde{\mathbf{X}}) \leq t\sigma_e^2, \\
& \text{C3: } \text{Tr}(\mathbf{Q}_c\tilde{\mathbf{X}}) \leq tP_r^{\max}. \tag{4.48}
\end{aligned}$$

Then the problem is solvable like the problem with power splitting relaying protocol. The optimal solution is denoted by $\tilde{\mathbf{X}}^*$, t^* . Then the solution of \mathbf{X} denoted by \mathbf{X}^* is obtained by $\mathbf{X}^* = \frac{\tilde{\mathbf{X}}^*}{t^*}$. If the rank of $\tilde{\mathbf{X}}^*$ is not one, we can employ

Theorem 1 to obtain the rank-one solution.

4.5 Numerical Results

In this section, simulation results are provided to evaluate the performance of the proposed secrecy rate optimization solution. The number of antenna is 3. We use the TGN path loss model with the directional transceiver antenna gain of 10 dBi. The distance between each node is set as 10 m. The carrier frequency is 470 MHz, which is accorded with the IEEE 802.11af Wi-Fi parameters [95]. The noise variance is assumed as $\sigma_r^2 = \sigma_c^2 = \sigma_d^2 = \sigma_e^2 = \sigma = -25$ dBm. The initial power at the relay node is 10 dBm. The energy conversion efficient is 0.8. The channel vectors are randomly generated from independent and identically distributed Rayleigh Rician random variables with Rician factor 6dB. The maximum SNR tolerance for the eavesdropper is assumed as -10 dB. Simulation results were averaged over 1000 independent trials.

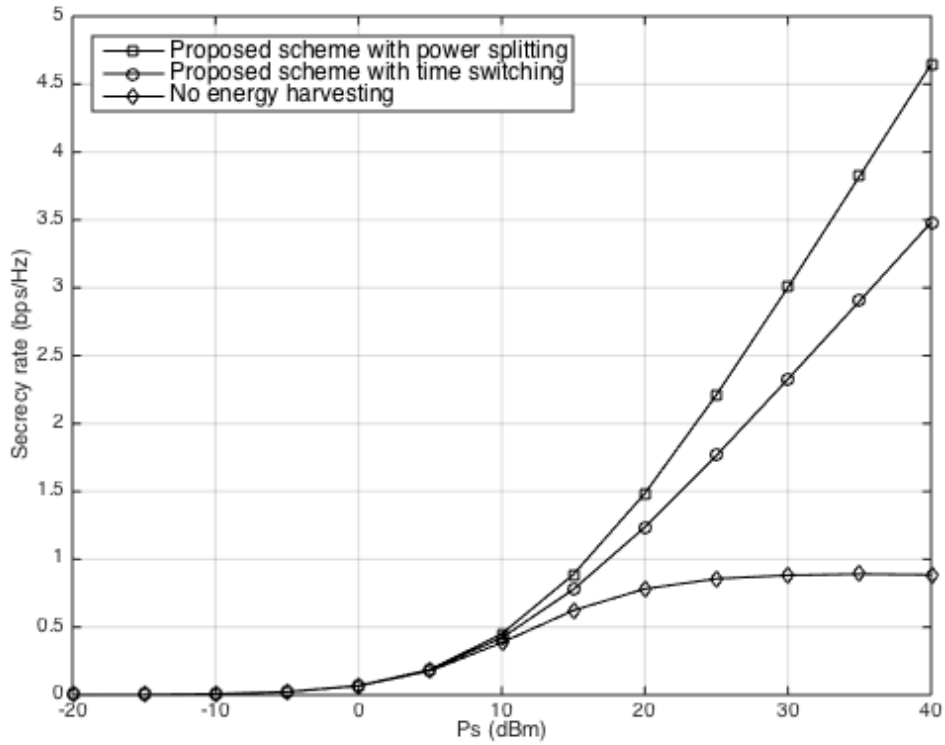

Figure 4.2: Secrecy rate versus transmitted power at the source node for the proposed schemes with energy harvesting protocols.

In Fig. (4.2), the secrecy rates achieved by different secure transmission schemes versus the transmitted power of the source are plotted. The results for power splitting relaying and time switching relaying schemes are obtained with its optimal energy harvesting coefficient, $\rho = 0.5$ and $\alpha = 0.3$. It can be seen that curves of secrecy rates for the two proposed energy harvesting schemes are monotonically non-decreasing functions of the transmitted power because the higher transmitted

power results in more available power at the relay for the relay-destination transmission. The proposed scheme with power splitting relaying protocol outperforms that with the time switching relaying protocol. For comparison, Fig. (4.2) also presents the performance for non-energy harvesting cooperative networks. In the non-energy harvesting scheme, the relay node only uses its initial power to relay the information. It can be observed that performances of two energy harvesting schemes and the non-energy scheme are close in the low source power region. This is because that if the transmitted power at the source node is small, the energy harvesting relay can not collect much power to improve the system performance. However, if the source transmitted power is large enough, the energy harvesting schemes can obviously outperform the non-energy harvesting scheme. The secrecy rate in the non-energy harvesting scheme is limited by the relay power and can not further be improved with the increased source power. From the figure, we can see that the energy harvesting relaying schemes have better performance than the non-energy harvesting scheme, which demonstrates that energy harvesting relay schemes can improve the secrecy rate in a resource-limited relay network context.

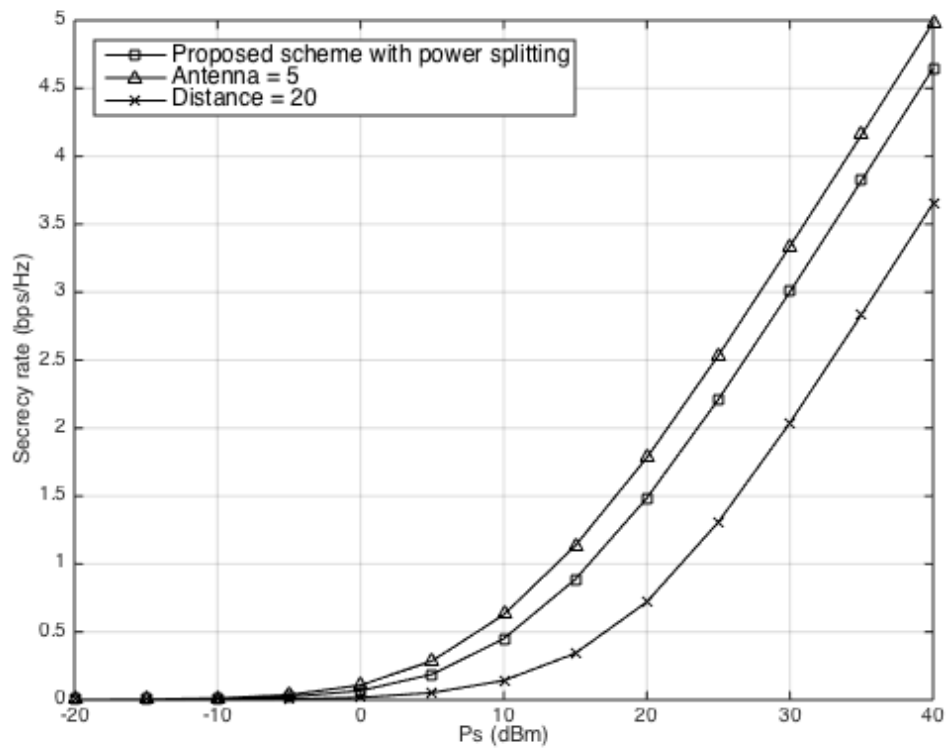

Figure 4.3: Secrecy rate versus transmitted power at the source node for the power splitting relaying protocol with different choices of system parameters.

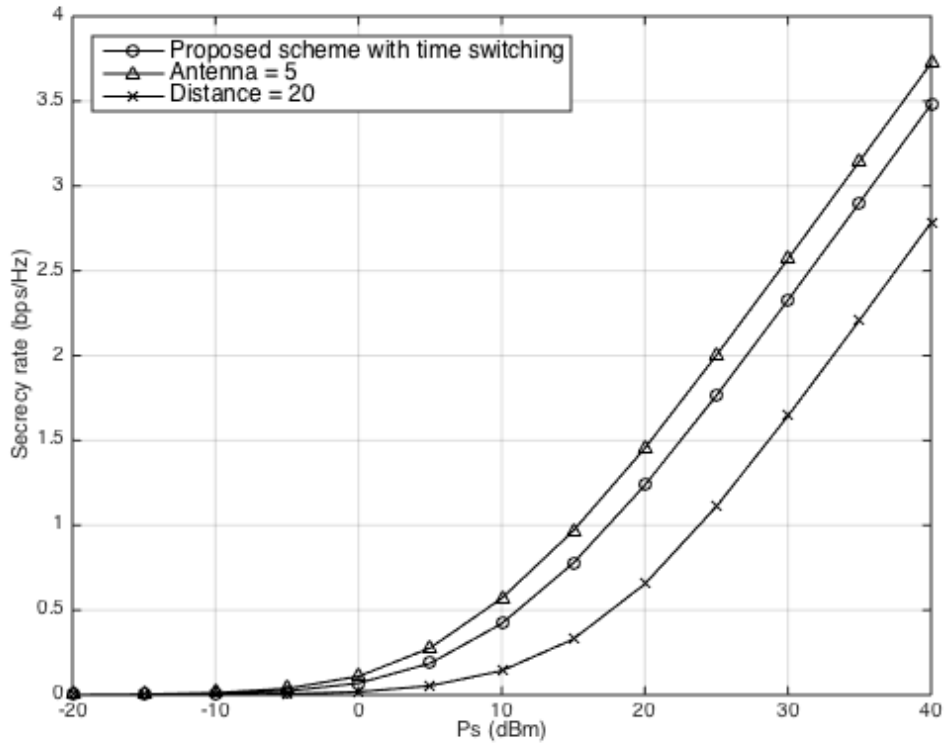

Figure 4.4: Secrecy rate versus transmitted power at the source node for the time switching relaying protocol with different choices of system parameters.

In Fig. (4.3) and Fig. (4.4), we present the secrecy rate versus the transmitted power for the proposed scheme with power splitting relaying and time switching relaying protocols by using different system parameters. It can be seen from the figure that the secrecy rates achieved by these two protocols improve with the increased number of the antenna and are degraded with the increase of the distance between each node. This is attributed to the fact that the relay could exploit the array gain to

achieve better performance with more antennas, and the longer distance makes channel attenuation larger in turns resulting in, the worse performance of relay networks.

4.6 Chapter Summary

In this chapter, we formulated the secrecy rate maximization in an AF relay network with power splitting relaying and time switching relaying energy harvesting protocols while taking into account relay precoding and the energy harvesting coefficient. The optimal solution was found by applying the SDP relaxation approach and 1-D optimization. Simulation results illustrated the energy harvesting relaying schemes could enhance the secrecy rate in a resource-limited relay network and analyzed the trade-off between the secrecy rate and system parameters.

Chapter 5

Beamforming Optimization in Energy Harvesting Cooperative Full-Duplex Networks with Self-Energy Recycling Protocol

5.1 Introduction

Many works regarding the energy harvesting cooperative network considered the half-duplex network model; however, the full-duplex model is another research interest in the wireless energy harvesting study. The authors in [96], [97] studied the full-duplex wireless powered network with the time switching protocol. Due to the full-duplex structure, the node could transmit energy and receive information simultaneously. The authors in [98] proposed a self-energy recycling protocol. In [98], a full-duplex energy harvesting relay node is equipped with two groups of the antenna. In the first transmission phase, the relay node uses its receiving antenna to receive the

information from the source node. In the second transmission phase, the relay node uses its receiving antenna to collect the power transmitted from the source node and uses its transmission antennas to send the information to the destination node. During the second phase, the energy harvesting relay not only collects the power from the source node but also recycles part of its transmitted power from its loop-back channel. The authors in [98] set up this self-energy recycling protocol in a MISO relaying channel.

Motivated by this, we study the beamforming optimization problem based on the self-energy recycling relaying protocol in a cooperative wireless network. We modeled a wireless energy harvesting cooperative network with a self-energy recycling relay. The relay node is equipped two groups of the antenna, so it is capable of collecting the information or energy and relaying the information simultaneously. In this model, we formulated the beamforming optimization problem for maximizing the achievable rate subject to the available transmitted power at the relay node and we used the SDP relaxation approach to solve it. To highlight the advantage of the self-energy recycling scheme, we also provided the solution for the beamforming

optimization problem with the time switching relaying protocol and the power splitting relaying protocol. Simulation results are provided to verify that the self-energy recycling relaying protocol achieves an obvious rate gain compared to the time switching relaying protocol or power splitting relaying protocol. The trade-off between the achievable rate and system parameters is also analyzed.

5.2 System Model

The cooperative wireless network considered here includes one source-destination pair and one energy harvesting relay. The source node and the destination node are equipped one antenna respectively. The relay node has two groups of the RF chains; one is used for the information transmission while the other one is used for receiving.

The number of transmission antennas N_t and the number of receiving antennas N_r are the same, i.e. $N_t = N_r = N$. We assume that there is no direct link between the source node and the destination node, i.e. the source node intends to transmit the message to the destination node with the assist of the relay node. Channels are

modeled as quasi-static block fading channels. The perfect channel state information is available at the relay node. The considered network is illustrated in Fig. (5.1).

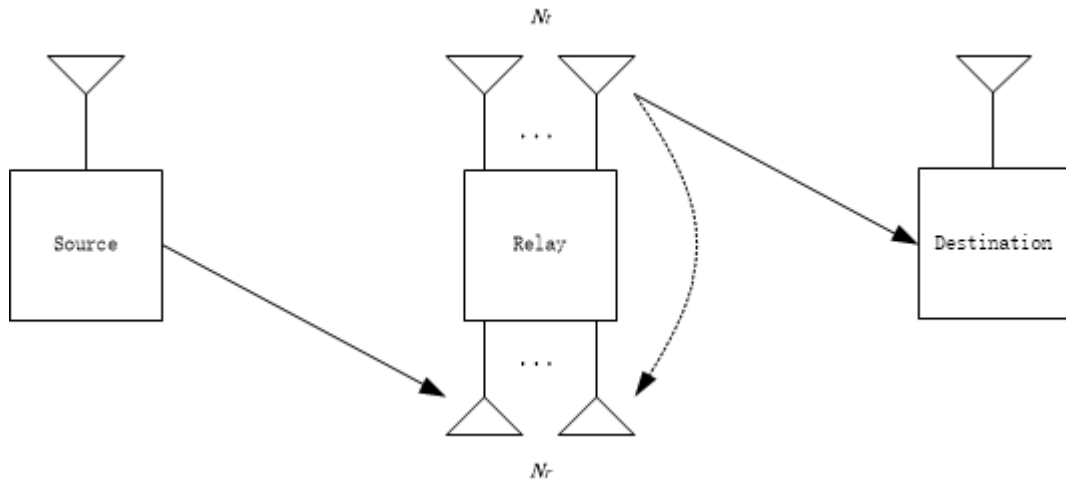

Figure 5.1: System model for energy harvesting cooperative network with self-energy recycling protocol.

The energy harvesting relay is solely powered by the source. It can harvest energy from the source node and utilize the energy to relay the source information. This assumption is used in [60]. The battery capacity of the energy harvesting relay is assumed as infinite. The AF scheme is employed in the cooperative network. A new energy harvesting protocol with self-energy recycling relay is considered in this chapter. The detailed analysis based on this protocol is given in the following sections.

We also assume that the relay node itself has the limited power to support its circuitry power consumption; however, the relay node does not use its power to relay the information. Therefore, the relay node needs to be wirelessly powered by the source node.

5.3 Beamforming with Self-Energy Recycling Relay

In this section, we study the relay beamforming optimization problem in the self-energy recycling relaying network. The transmission model is given as follows.

5.3.1 Relay Protocol and Transmission Model

The whole transmission process is operated in the block time, denoted by T . The information transmission process is split into two phases. In the first phase, the source transmits information to the relay for $\frac{T}{2}$ time, and relay uses its receiving antennas to receive information. In the second phase, the source node transmits RF signals to

power the energy harvesting relay and the relay sends the amplified information to the destination. The energy harvesting relay is equipped with one group of the transmission antenna and one group of receiving antenna. The receiving antennas at the relay node harvest energy and use the harvested energy to assist transmission antennas to relay information. It is noted that the full-duplex relay node needs some time to harvest energy and then relay information, therefore there is delay between these two procedures. However the delay could be very small and is ignored in this work.

The energy harvesting relay first receives the information from the source node with its receiving antennas. The received signal at the relay can be expressed as

$$\mathbf{y}_r^1 = \sqrt{P_s} \mathbf{h}_r x_s + \mathbf{n}_{r1}, \quad (5.1)$$

where P_s is the transmitted power, $\mathbf{h}_r \in \mathbb{C}^{N \times 1}$ is the channel vector from the source to receiving antennas of the relay, and x_s is the transmitted data from the source node with $\mathcal{E}(|x_s|^2) = 1$ and \mathbf{n}_{r1} is the additive complex Gaussian noise vector at the relay node following $\mathcal{CN}(\mathbf{0}, \sigma_{r1}^2 \mathbf{I}_N)$.

Since the energy harvesting relay is operated with the AF protocol, upon receiving

the signal, the relay processes the signal by the relay precoding. The signal transmitted by the relay node is given by

$$\mathbf{x}_r = \sqrt{P_s} \mathbf{W} \mathbf{h}_r x_s + \mathbf{W} \mathbf{n}_{r1}, \quad (5.2)$$

where $\mathbf{W} \in \mathbb{C}^{N \times N}$ is the precoding matrix. The power of the transmitted signal from the relay is

$$P_r = P_s \|\mathbf{W} \mathbf{h}_r\|^2 + \sigma_{r1}^2 \|\mathbf{W}\|^2, \quad (5.3)$$

In the second phase, the relay uses its transmission antennas to relay the information to the destination node. The received signal at the destination is given by

$$y_d = \sqrt{P_s} \mathbf{h}_d^H \mathbf{W} \mathbf{h}_r x_s + \mathbf{h}_d^H \mathbf{W} \mathbf{n}_{r1} + n_d, \quad (5.4)$$

where $\mathbf{h}_d \in \mathbb{C}^{N \times 1}$ is the channel vector between the transmission antennas of the relay and the destination node and n_d is additive Gaussian noise at the destination following $\mathcal{CN}(0, \sigma_d^2)$. Concurrently, the energy harvesting relay is wirelessly powered by the source node with the dedicated energy-bearing signal. The received signal at the relay is

$$\begin{aligned} y_r^2 &= \sqrt{P_s} \mathbf{h}_r x_e + \mathbf{H}_r x_r + \mathbf{n}_{r2}, \\ &= \sqrt{P_s} \mathbf{h}_r x_e + \sqrt{P_s} \mathbf{H}_r \mathbf{W} \mathbf{h}_r x_s + \mathbf{H}_r \mathbf{W} \mathbf{n}_{r1} + \mathbf{n}_{r2}, \end{aligned} \quad (5.5)$$

where x_e is the transmitted signal from the source node with $\mathcal{E}(|x_e|^2) = 1$, $\mathbf{H}_r \in \mathbb{C}^{N \times N}$ is the channel matrix of the loop channel at the relay node and \mathbf{n}_{r2} is the received additive complex Gaussian noise vector following $\mathcal{CN}(0, \sigma_{r2}^2 \mathbf{I}_N)$. The relay node not only collects energy from the source node but also recycles part of its transmitted power due to its two groups of antennas being activated at the same time. Unlike the other full-duplex relaying studies, the relay node employs interference cancellation techniques to eliminate the loop-back interference signal. In the energy harvesting cooperative relaying network, the loop-back signal can be reused at the relay as the transmitted power. The amount of the harvested energy is given by

$$E = \frac{\eta T}{2} (P_s \|\mathbf{h}_r\|^2 + P_s \|\mathbf{H}_r \mathbf{W} \mathbf{h}_r\|^2 + \sigma_{r1}^2 \|\mathbf{H}_r \mathbf{W}\|^2 + \sigma_{r2}^2), \quad (5.6)$$

where η is the energy conversion efficiency coefficient at the relay. Then the total available transmitted power at the relay node is $\frac{E}{T/2}$ which can be expressed as

$$P_r^{max} = \eta (P_s \|\mathbf{h}_r\|^2 + P_s \|\mathbf{H}_r \mathbf{W} \mathbf{h}_r\|^2 + \sigma_{r1}^2 \|\mathbf{H}_r \mathbf{W}\|^2 + \sigma_{r2}^2), \quad (5.7)$$

According to the aforementioned signal model, the received SNR at the destination node is

$$SNR_d = \frac{P_s |\mathbf{h}_d^H \mathbf{W} \mathbf{h}_r|^2}{\sigma_{r1}^2 \|\mathbf{h}_d^H \mathbf{W}\|^2 + \sigma_d^2}, \quad (5.8)$$

The achievable rate can be presented as

$$R = \frac{1}{2} \log_2(1 + SNR_d), \quad (5.9)$$

5.3.2 Problem Formulation and Beamforming Design

In this section, we consider the beamforming optimization problem for the considered network. We formulate the problem to maximize the achievable rate subject to the transmitted power constraint at the relay node. Particularly, the addressed optimization problem is formulated as follows

$$\begin{aligned} & \max_{\mathbf{W}} R \\ & s. t. P_r \leq P_r^{max}. \end{aligned} \quad (5.10)$$

It is noted that in the constraint, the transmitted power at the relay node may not use the total available power from the energy harvesting and this may results in that there will be the leftover of energy at the relay node stored for the next block time. However, in the simulation, the relay node always uses the total available at the relay node to maximize the objective function, so the above concern does not exist in this

optimization problem.

It is evident that the problem stated above is not a standard convex problem. Then, we proposed an optimal solution based on SDP relaxation. By using the monotonicity, the original problem can be expressed as

$$\begin{aligned} & \max_{\mathbf{W}} \frac{P_s |\mathbf{h}_d^H \mathbf{W} \mathbf{h}_r|^2}{\sigma_{r1}^2 \|\mathbf{h}_d^H \mathbf{W}\|^2 + \sigma_d^2} \\ & s. t. P_s \|\mathbf{W} \mathbf{h}_r\|^2 + \sigma_{r1}^2 \|\mathbf{W}\|^2 \\ & \leq \eta (P_s \|\mathbf{h}_r\|^2 + P_s \|\mathbf{H}_r \mathbf{W} \mathbf{h}_r\|^2 + \sigma_{r1}^2 \|\mathbf{H}_r \mathbf{W}\|^2 + \sigma_{r2}^2). \end{aligned} \quad (5.11)$$

The beamforming matrix in our considered network can be decomposed as $\mathbf{W} = \mathbf{w}_t \mathbf{w}_r^H$. $\mathbf{w}_t \in \mathbb{C}^{N \times 1}$ is the transmission beamforming vector at the relay node. $\mathbf{w}_r \in \mathbb{C}^{N \times 1}$ is the receiving beamforming vector with $\|\mathbf{w}_r\| = 1$. We further choose the structure of the receiving beamforming as $\|\mathbf{w}_r\| = \frac{\mathbf{h}_r}{\|\mathbf{h}_r\|}$, this MRC structure can strengthen the received signal or power and it is widely used [69], [99]. Therefore, the problem can be further expressed as

$$\begin{aligned} & \max_{\mathbf{w}_t} \frac{P_s |\mathbf{h}_d^H \mathbf{w}_t|^2 |\mathbf{w}_r^H \mathbf{h}_r|^2}{\sigma_{r1}^2 |\mathbf{h}_d^H \mathbf{w}_t|^2 + \sigma_d^2} \\ & s. t. P_s \|\mathbf{w}_t\|^2 |\mathbf{w}_r^H \mathbf{h}_r|^2 + \sigma_{r1}^2 \|\mathbf{w}_t\|^2 \\ & \leq \eta (P_s \|\mathbf{h}_r\|^2 + P_s \|\mathbf{H}_r \mathbf{w}_t\|^2 |\mathbf{w}_r^H \mathbf{h}_r|^2 + \sigma_{r1}^2 \|\mathbf{H}_r \mathbf{w}_t\|^2 + \sigma_{r2}^2). \end{aligned} \quad (5.12)$$

The above problem has one variable \mathbf{w}_t . Here we can find that the objective function in the above problem is an increasing function in $|\mathbf{h}_d^H \mathbf{w}_t|^2$. By using the monotonicity again, the problem can be simplified as

$$\begin{aligned} & \max_{\mathbf{w}_t} |\mathbf{h}_d^H \mathbf{w}_t|^2 \\ & s. t. (\|\mathbf{w}_t\|^2 - \|\mathbf{H}_r \mathbf{w}_t\|^2 \eta) (P_s |\mathbf{w}_r^H \mathbf{h}_r|^2 + \sigma_{r1}^2) \\ & \leq \eta P_s \|\mathbf{h}_r\|^2 + \eta \sigma_{r2}^2. \end{aligned} \quad (5.13)$$

The transformed problem is a quadratic form and we employ SDP relaxation to solve it. Define a new variable $\mathbf{X} = \mathbf{w}_t \mathbf{w}_t^H$, the optimization problem can be reformulated as

$$\begin{aligned} & \max_{\mathbf{X} \succeq \mathbf{0}} \text{Tr}(\mathbf{Q}_1 \mathbf{X}) \\ & s. t. \text{Rank}(\mathbf{X}) = 1, \\ & \text{Tr}(\mathbf{Q}_2 \mathbf{X}) \leq \frac{\eta P_s \|\mathbf{h}_r\|^2 + \eta \sigma_{r2}^2}{P_s |\mathbf{w}_r^H \mathbf{h}_r|^2 + \sigma_{r1}^2}. \end{aligned} \quad (5.14)$$

where $\mathbf{Q}_1 = \mathbf{h}_d \mathbf{h}_d^H$, $\mathbf{Q}_2 = \mathbf{I} - \eta \mathbf{H}_r^H \mathbf{H}_r$.

It can be seen that the rank-one constraint makes the problem still difficult to solve.

Therefore, we drop the rank-one constraint, and a SDP problem can be obtained as

$$\max_{\mathbf{X} \succeq \mathbf{0}} \text{Tr}(\mathbf{Q}_1 \mathbf{X})$$

$$s. t. Tr(\mathbf{Q}_2 \mathbf{X}) \leq \frac{\eta P_s \|\mathbf{h}_r\|^2 + \eta \sigma_{r2}^2}{P_s |\mathbf{w}_r^H \mathbf{h}_r|^2 + \sigma_{r1}^2}. \quad (5.15)$$

Then the problem is a standard SDP problem, and one can efficiently find its global optimal solution via available solvers [92]. If the rank of \mathbf{X}^* is one, \mathbf{w}_t is exactly computed via eigenvalue decomposition. Otherwise, we can use the SBP rank reduction theorem which is obtained from the result in [93] to obtain the rank-one solution.

5.4 Beamforming with Time Switching Relaying Protocol

In this section, we study the beamforming optimization based on the time switching relaying protocol as a benchmark. Compared with to time switching relaying protocol, the self-energy recycling protocol does not need to allocate dedicated time slot for the energy transmission, thus has the potential to improve the throughput. The energy harvesting relay in time switching relaying protocol operates in half-duplex mode. The transmission model with the time switching relaying protocol and the corresponding optimization problem are given as follows.

5.4.1 Time Switching Relaying Protocol and Transmission

Model

In the time-switching relaying protocol, the information transmission process is split into three phases. In the first phase, the source transmits RF signals to power the energy harvesting relay for αT , where T denotes the duration of one block and $0 \leq \alpha \leq 1$. During the rest of the block time $(1 - \alpha)T$, the information is transmitted from the source to the relay and then the relay will use the harvested energy to deliver the source information the destination.

The energy harvesting relay harvests the energy in the first phase. The received signal at the relay can be expressed as follows

$$\mathbf{y}_r = \sqrt{P_s} \mathbf{h}_r x_e + \mathbf{n}_{r3}, \quad (5.16)$$

where P_s is the transmitted power at the source node, $\mathbf{h}_r \in \mathbb{C}^{N \times 1}$ denotes the channel vector the between the source node and the relay node, x_e is the dedicated energy-bearing signal from the source node with $\mathcal{E}(|x_e|^2) = 1$ and \mathbf{n}_{r3} is the

additive complex Gaussian noise vector at the relay node following $\mathcal{CN}(0, \sigma_{r3}^2 \mathbf{I}_N)$.

The relay harvests energy from the RF signal sent by the source for α time, and the amount of the harvested energy is given by

$$E = \eta\alpha(P_s \|\mathbf{h}_r\|^2 + \sigma_{r3}^2)T, \quad (5.17)$$

where η is the energy conversion efficiency coefficient at the relay. Therefore, the total available transmitted power at the relay is then expressed as follows

$$P_r^{max} = \frac{2\eta\alpha(P_s \|\mathbf{h}_r\|^2 + \sigma_{r3}^2)}{1 - \alpha}, \quad (5.18)$$

After the energy transmission, the received information from the source node to the relay node can be expressed as

$$\mathbf{y}_r = \sqrt{P_s} \mathbf{h}_r x_s + \mathbf{n}_{r4} + \mathbf{n}_c, \quad (5.19)$$

where x_s is the dedicated information-bearing signal from the source node with $\mathcal{E}(|x_s|^2) = 1$, \mathbf{n}_{r4} is the additive complex Gaussian noise vector at the relay node following $\mathcal{CN}(0, \sigma_{r4}^2 \mathbf{I}_N)$ and \mathbf{n}_c is the additive complex Gaussian noise vector due to the RF to baseband conversion following $\mathcal{CN}(0, \sigma_c^2 \mathbf{I}_N)$.

Since the energy harvesting relay is operated with the AF protocol, the signal transmitted by the relay node can be written as follows

$$\mathbf{x}_r = \sqrt{P_s} \mathbf{W} \mathbf{h}_r x_s + \mathbf{W} \mathbf{n}_{r4} + \mathbf{W} \mathbf{n}_c, \quad (5.20)$$

where $\mathbf{W} \in \mathbb{C}^{N \times N}$ is the precoding matrix.

The relay transmission power is given by

$$P_r = P_s \|\mathbf{W} \mathbf{h}_r\|^2 + \sigma_{r4}^2 \|\mathbf{W}\|^2 + \sigma_c^2 \|\mathbf{W}\|^2, \quad (5.21)$$

Then the received signal at the destination node is given by

$$y_d = \sqrt{P_s} \mathbf{h}_d^H \mathbf{W} \mathbf{h}_r x_s + \mathbf{h}_d^H \mathbf{W} \mathbf{n}_{r4} + \mathbf{h}_d^H \mathbf{W} \mathbf{n}_c + n_d, \quad (5.22)$$

where $\mathbf{h}_d \in \mathbb{C}^{N \times 1}$ denotes the channel vector between the relay node and the destination node and n_d is the additive Gaussian noise at the destination following $\mathcal{CN}(0, \sigma_d^2)$.

According to the described signal model, the received SNR at the destination node is

$$SNR_d = \frac{P_s |\mathbf{h}_d^H \mathbf{W} \mathbf{h}_r|^2}{\sigma_{r4}^2 \|\mathbf{h}_d^H \mathbf{W}\|^2 + \sigma_c^2 \|\mathbf{h}_d^H \mathbf{W}\|^2 + \sigma_d^2}, \quad (5.23)$$

The achievable rate can be expressed as

$$R = \frac{1 - \alpha}{2} \log_2(1 + SNR_d), \quad (5.24)$$

5.4.2 Problem Formulation and Beamforming Design

We formulate the beamforming optimization problem of maximizing the achievable rate subject to the transmitted power constraint at the relay node. The optimization problem is formulated as follows

$$\begin{aligned} & \max_{\mathbf{W}, \alpha} R \\ & s. t. P_r \leq P_r^{max}. \end{aligned} \quad (5.25)$$

This problem is in a form similar to the one proposed in the previous section and is also not a standard convex problem. By using the monotonicity, the problem can be expressed by

$$\begin{aligned} & \max_{\mathbf{W}, \alpha} \frac{P_s |\mathbf{h}_d^H \mathbf{W} \mathbf{h}_r|^2}{\sigma_{r1}^2 \|\mathbf{h}_d^H \mathbf{W}\|^2 + \sigma_c^2 \|\mathbf{h}_d^H \mathbf{W}\|^2 + \sigma_d^2} \\ & s. t. P_s \|\mathbf{W} \mathbf{h}_r\|^2 + \sigma_{r1}^2 \|\mathbf{W}\|^2 + \sigma_c^2 \|\mathbf{W}\|^2 \leq \frac{2\eta\alpha(P_s \|\mathbf{h}_r\|^2 + \sigma_{r3}^2)}{1 - \alpha}. \end{aligned} \quad (5.26)$$

For the problem above, we first transform the objective function as

$$\begin{aligned} SNR_d &= \frac{P_s |\mathbf{h}_d^H \mathbf{W} \mathbf{h}_r|^2}{\sigma_{r4}^2 \|\mathbf{h}_d^H \mathbf{W}\|^2 + \sigma_c^2 \|\mathbf{h}_d^H \mathbf{W}\|^2 + \sigma_d^2}, \\ &= \frac{P_s \mathbf{w}^H \mathbf{h} \mathbf{h}^H \mathbf{w}}{\sigma_{r4}^2 \mathbf{w}^H \mathbf{H}_1 \mathbf{H}_1^H \mathbf{w} + \sigma_c^2 \mathbf{w}^H \mathbf{H}_1 \mathbf{H}_1^H \mathbf{w} + \sigma_d^2}, \end{aligned} \quad (5.27)$$

where $\mathbf{w} = \text{vec}(\mathbf{W})$, $\mathbf{h} = \mathbf{h}_r^* \otimes \mathbf{h}_d$ and $\mathbf{H}_1 = \mathbf{I} \otimes \mathbf{h}_d$. The above transform is

obtained by using the rule as follows [100]

$$\text{vec}(\mathbf{ABC}) = (\mathbf{C}^T \otimes \mathbf{A})\text{vec}(\mathbf{B}), \quad (5.28)$$

The transmitted power constraint can be rewritten as

$$\begin{aligned} P_r &= P_s \|\mathbf{W}\mathbf{h}_r\|^2 + \sigma_{r_4}^2 \|\mathbf{W}\|^2 + \sigma_c^2 \|\mathbf{W}\|^2, \\ &= P_s \mathbf{w}^H \mathbf{H}_2 \mathbf{H}_2^H \mathbf{w} + \sigma_{r_4}^2 \mathbf{w}^H \mathbf{w} + \sigma_c^2 \mathbf{w}^H \mathbf{w}, \end{aligned} \quad (5.29)$$

where $\mathbf{H}_2 = \mathbf{h}_r^* \otimes \mathbf{I}$.

Define a new variable $\mathbf{X} = \mathbf{w}\mathbf{w}^H$, the optimization problem can be reformulated as

$$\begin{aligned} &\max_{\mathbf{X} \succeq \mathbf{0}, \alpha} \frac{\text{Tr}(\mathbf{Q}_1 \mathbf{X})}{\text{Tr}(\mathbf{Q}_2 \mathbf{X}) + \sigma_d^2} \\ &s. t. \text{Rank}(\mathbf{X}) = 1, \\ &0 \leq \alpha \leq 1, \\ &\text{Tr}(\mathbf{Q}_3 \mathbf{X}) \leq \frac{2\eta\alpha(P_s \|\mathbf{h}_r\|^2 + \sigma_{r_3}^2)}{1 - \alpha}. \end{aligned} \quad (5.30)$$

where $\mathbf{Q}_1 = P_s \mathbf{h}\mathbf{h}^H$, $\mathbf{Q}_2 = (\sigma_{r_4}^2 + \sigma_c^2) \mathbf{H}_1 \mathbf{H}_1^H$ and $\mathbf{Q}_3 = P_s \mathbf{H}_2 \mathbf{H}_2^H + \sigma_{r_4}^2 \mathbf{I} + \sigma_c^2 \mathbf{I}$.

It is worthy to point out that it is still challenging to solve this problem directly, mainly due to the rank one constraint and the time switching coefficient in the problem, which renders the optimization problem non-convex. To tackle these difficulties, we can drop the rank one constraint. Then we can perform the full search on the time-switching coefficient. Specifically, for a given time-switching coefficient,

the optimal relay beamforming matrix can be efficiently obtained. We perform a full search on the time-switching coefficient, then solve the problem with all possible value of the time-switching coefficient. In practice, we can discretize the range of the time-switching coefficient into $M \gg 1$ equally spaced intervals with an interval width of $\frac{1}{M}$ for facilitating the full search. After we obtain all achievable SNR value, we can select the best among those possible choices of the time-switching coefficient. Once the value of α is fixed, the problem can be treated as a quasi-convex SDP problem, where we drop the rank one constraint. Instead of employing the bisection search approach, we use the Charnes-Cooper transformation [91] to solve it. Specifically, we define a new variable $t = \frac{1}{Tr(\mathbf{Q}_2\mathbf{X}) + \sigma_d^2}$ and let $\tilde{\mathbf{X}} = t\mathbf{X}$. The problem can be recast as follows

$$\begin{aligned}
& \max_{\tilde{\mathbf{X}} \succeq \mathbf{0}, t} Tr(\mathbf{Q}_1\tilde{\mathbf{X}}) \\
& s. t. Tr(\mathbf{Q}_2\tilde{\mathbf{X}}) + t\sigma_d^2 = 1, \\
& Tr(\mathbf{Q}_3\tilde{\mathbf{X}}) \leq \frac{2t\eta\alpha(P_s\|\mathbf{h}_r\|^2 + \sigma_{r3}^2)}{1 - \alpha}. \tag{5.31}
\end{aligned}$$

Then the problem is solvable like the problem with the self-energy recycling relaying protocol. The optimal solution is denoted by $\tilde{\mathbf{X}}^*$, t^* . Then the solution of \mathbf{X} denoted

by \mathbf{X}^* is obtained by $\mathbf{X}^* = \frac{\tilde{\mathbf{X}}^*}{t^*}$. If the rank of $\tilde{\mathbf{X}}^*$ is not one, we can also use the SBP rank reduction theorem to obtain the rank-one solution.

It is necessary to mention that we can also use the power splitting relaying protocol as another benchmark scheme compared with the self-energy recycling scheme. The power splitting relaying protocol can be referred as [60]. Our method to optimize the beamforming with the time switching relaying protocol is easily extended to the same optimization problem based on the power splitting relaying protocol. Hence, we omit its detailed procedure here, and we provide its simulation result in the next section.

5.5 Numerical Results

In this section, simulation results are provided to evaluate the performance of the proposed beamforming optimization solution. The number of antenna is 3. We use the TGN path loss model [101]. The loop channel path loss is -15 dB [102]. The distance between each node is set as 10 m. The system bandwidth is 200 kHz. The carrier

frequency is 470 MHz, which is accorded with the IEEE 802.11af Wi-Fi parameters [95]. The channel vectors are randomly generated from independent and identically distributed Rayleigh Rician random variables with Rician factor 6dB. The noise variance is assumed as $\sigma_{r_1}^2 = \sigma_{r_2}^2 = \sigma_{r_3}^2 = \sigma_{r_4}^2 = \sigma_c^2 = \sigma_d^2 = -25$ dBm. The energy conversion efficient is 0.8. Simulation results were averaged over 1000 independent trials.

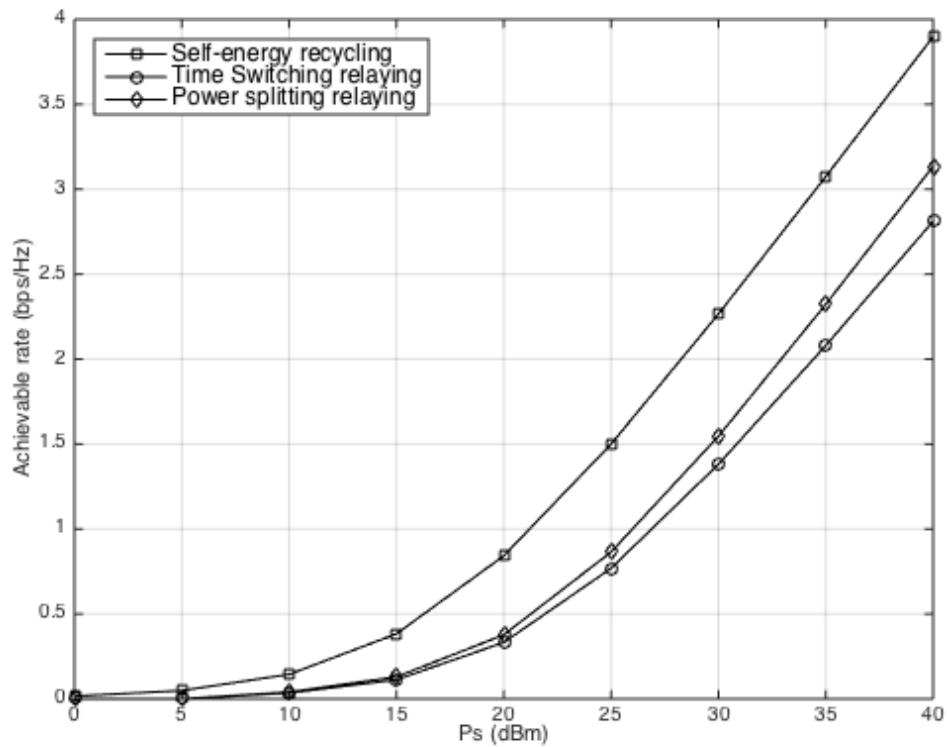

Figure 5.2: Achievable rate versus transmitted power at the source node for different energy harvesting protocols.

In Fig. (5.2), the achievable rates achieved by different energy harvesting protocols versus the transmitted power of the source are plotted. The result for the self-energy recycling protocol is demonstrated and the results for the time switching relaying protocol and the power splitting relaying protocol are also shown as benchmarks. The results for time switching relaying and power splitting relaying protocols are obtained with their optimal energy harvesting coefficient. It can be seen that curves of the achievable rate for these energy harvesting protocols are monotonically non-decreasing functions of the transmitted power because the higher transmitted power results in more available power at the relay for the relay-destination transmission. The self-energy recycling scheme outperforms the time switching relaying and power splitting relaying protocols. This is because that the full-duplex structure relay used in the self-energy recycling relaying protocol not only harvests the power transmitted from the source node but also recycles the part of transmitted power at the relay node. Compared to the time switching relaying and power splitting relaying protocols, the self-energy harvesting protocol achieves an obvious rate gain.

The self-energy recycling protocol has better performance than the other energy harvesting protocols.

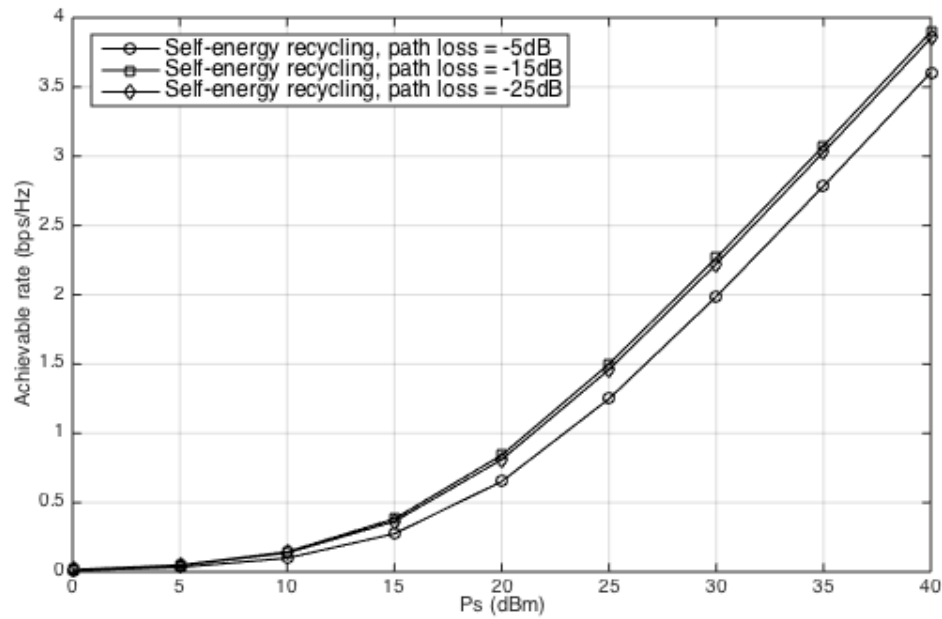

Figure 5.3: Achievable rate versus transmitted power at the source node for the self-energy recycling relaying protocol with different loop channel path loss.

In Fig. (5.3), the performances of the self-energy recycling protocol with different loop channel path loss are presented. From the figure, we can see that the system performance with the path loss -15 dB is better than that with the path loss -5 dB or -25 dB. This is due to that if the path loss is smaller, the energy harvesting relay

cannot recycle more power in the second transmission phase, which leads to the available transmitted power at the relay node is smaller. However, if the loop channel path loss is too large, it will deteriorate the system performance, even though the relay can harvest more power.

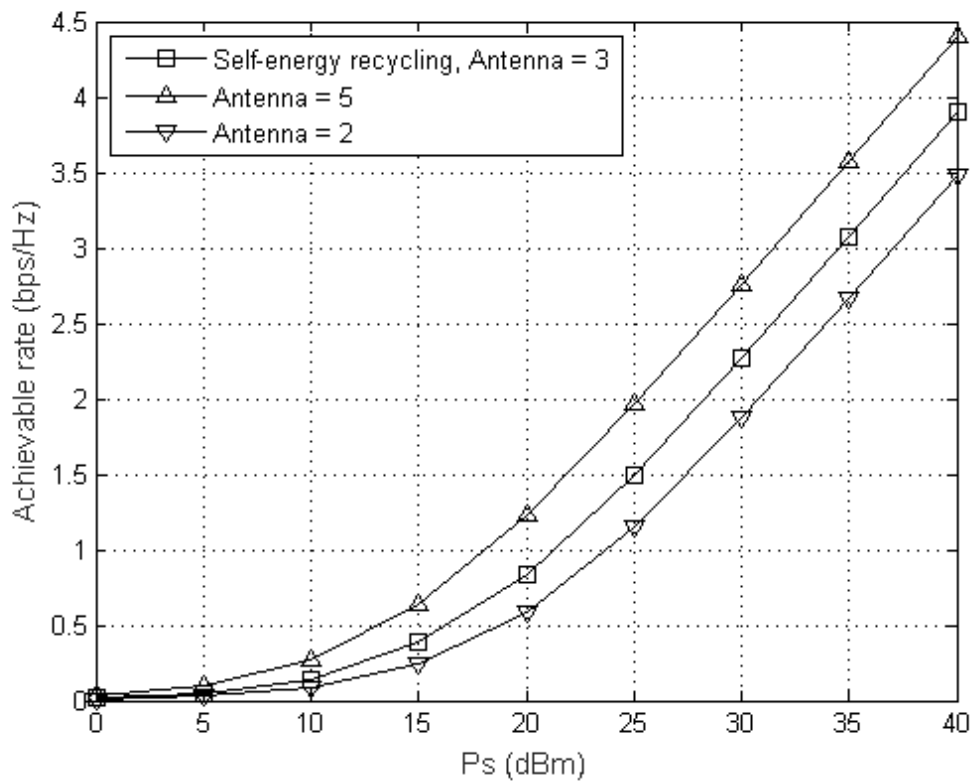

Figure 5.4: Performance comparison of the self-energy recycling protocol with different numbers of antenna.

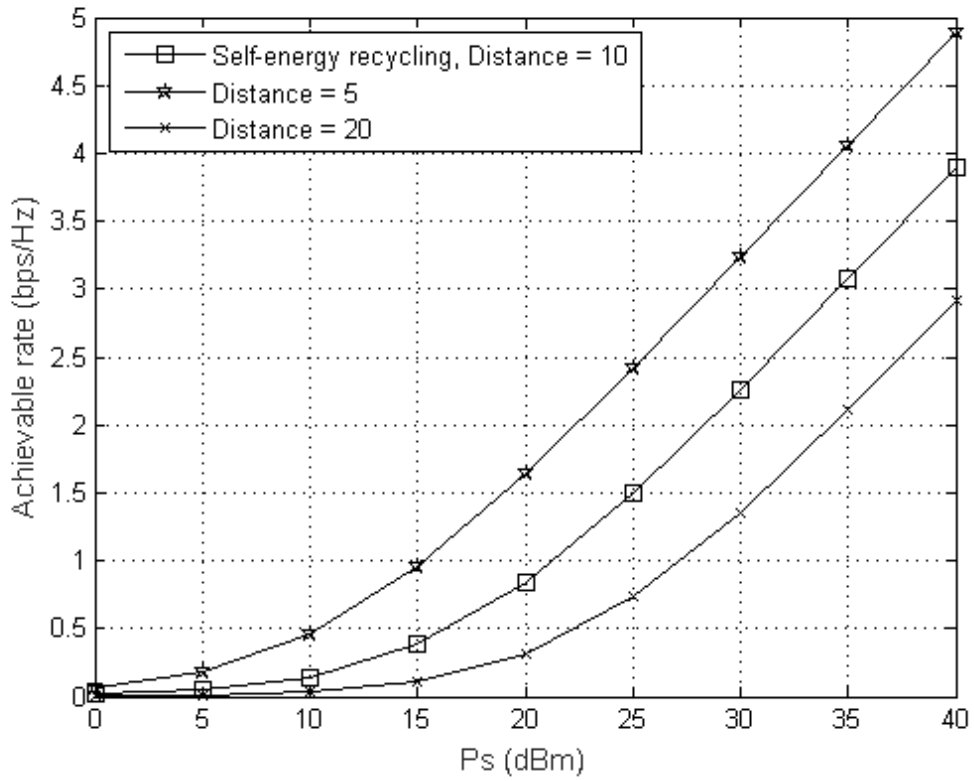

Figure 5.5: Performance comparison of the self-energy recycling protocol with different numbers of distances.

In Fig. (5.4) and Fig. (5.5), we present the achievable rate versus the transmitted power for the self-energy recycling relaying protocol with different system parameters. It can be seen from the figure that the achievable rate improves with the increased number of the antenna and is degraded with the increase of the distance between each node. This is attributed to the fact that the relay could exploit the array gain to achieve better performance with more antennas, and the longer distance makes channel

attenuation larger in turns resulting in, the worse performance of relay networks.

5.6 Chapter Summary

In this paper, we formulated the beamforming optimization problem in an AF relay network based on the self-energy recycling relaying protocol. We proposed a SDP-based solution to obtain the optimal solution for the proposed problem. To demonstrate the advantage of the self-energy recycling relaying protocol, we also used the SDP relaxation and the full search to solve the beamforming optimization problem with the time switching relaying protocol and power splitting relaying protocol. Simulation results illustrated that the self-energy recycling relaying protocol can improve the achievable rate compared to other energy harvesting protocols. The trade-off between the achievable rate and system parameters is also provided in the chapter.

Chapter 6

Beamforming Optimization for Full-Duplex Cooperative Cognitive Radio Networks with Self-Energy Recycling Protocol

6.1 Introduction

The cooperation between the primary system and the secondary system in a cognitive radio network was illustrated to improve the spectrum efficiency [103], [104], [105], [106], [107], [108], [109]. When the PU's rate requirement can not be met, the secondary system assists in relaying the primary information for the PU and also uses the primary spectrum. Hence the primary system and the secondary system both benefit from the cooperation. In [106] and [107], a three phase transmission protocol was proposed. Specifically, in phase 1 and phase 2, the ST receives the primary information and then forwards to the PU. In phase 3, the ST sends its information to

the SU. In [103], [108] and [109], multiple antennas was employed at the ST, in which the cooperation requires two phase. In phase 1, the ST listens to the primary information. In phase 2, the ST both forwards the primary information and its information. However, many works only considered the cooperation between the primary system and the secondary system regarding the information level. From a practical perspective, if the ST is willing to assist the primary transmission but faces a problem that its energy can not support the information cooperation, the information cooperation will not be completed. To solve this problem, we introduce the emerging wireless energy harvesting technology into the cooperative cognitive radio network.

In this chapter, we study the beamforming optimization problem based on the self-energy recycling relaying protocol in a cooperative cognitive radio network. We modeled a wireless energy harvesting cooperative cognitive radio network with a self-energy recycling relay. The ST is equipped two groups of the antenna, so it is capable of collecting the information or energy and relaying the information simultaneously. In this model, we formulated the beamforming optimization problem for maximizing the achievable SU's rate subject to the available transmitted power at

the ST and the minimum PU's rate. We used the SDP relaxation approach to solving it. To highlight the advantage of the self-energy recycling scheme, we also provided the solution for the beamforming optimization problem with the power splitting relaying protocol. Simulation results are provided to verify that the self-energy recycling relaying protocol achieves an obvious rate gain compared to the power splitting relaying protocol. The trade-off between the achievable rate and system parameters is also analyzed.

6.2 System Model

The cognitive relay network considered in the chapter includes a primary system and a secondary system. The secondary system consists of a secondary transmitter-receiver pair. The primary system has a primary transmitter-receiver pair, which intends to communicate in a licensed frequency band. We assume that the link between the PT and PU is affected with the deep fading or shadowing effects, hence to meet the primary system's rate requirement, the ST assists in relaying the primary system's

information. The ST is an energy harvesting node [60], which has an initial energy and further harvests energy from the PT. The ST receives the PT's information and energy; it uses the harvested energy together with its energy to transmit the information to the SU and to assist the primary system. The battery capacity of the ST is assumed as infinite. The AF scheme is employed at the ST node. A self-energy recycling protocol is employed at the energy harvesting node. The detailed analysis based on this protocol is given in the following section.

Except the ST, all nodes are equipped one antenna. The ST has two groups of RF chains; one is used for transmitting while the other one is used for receiving. The number of transmission antennas N_t and the number of receiving antennas N_r are same, i.e. $N_t = N_r = N$. The perfect channel state information is assumed available at the ST. Channels are modeled as quasi-static block fading channels. The considered model is illustrated in Fig. (6.1).

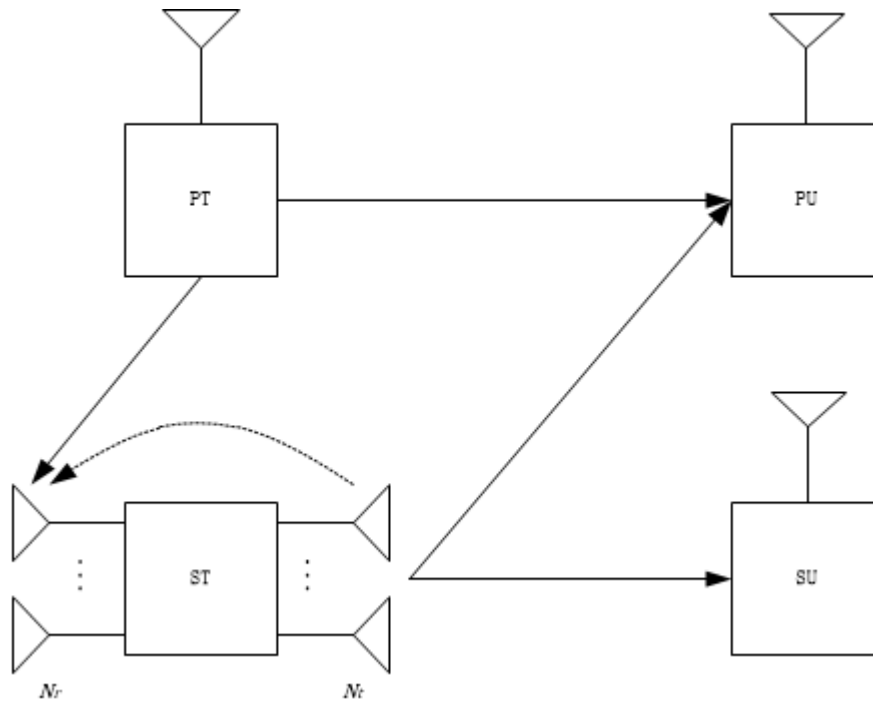

Figure 6.1: System model for full-duplex cooperative cognitive radio network with self-energy recycling protocol.

6.3 Beamforming with Self-Energy Recycling Protocol

In this section, we introduce the self-energy recycling protocol and study the beamforming optimization problem for the cooperative cognitive network.

6.3.1 Self-Energy Recycling Protocol and Transmission

Model

The PT broadcasts the information firstly. The ST receives the information from the PT with its receiving antenna. The received information can be expressed as

$$\mathbf{y}_r^1 = \sqrt{P_p} \mathbf{h} x_p + \mathbf{n}_{r1}, \quad (6.1)$$

where P_p is the transmitted power at the PT, $\mathbf{h} \in \mathbb{C}^{N \times 1}$ is the channel vector from the PT to receiving antennas of the ST, and x_p is the transmitted information from the PT with $\mathcal{E}(|x_p|^2) = 1$ and \mathbf{n}_{r1} is the additive complex Gaussian noise vector at the ST following $\mathcal{CN}(\mathbf{0}, \sigma_{r1}^2 \mathbf{I}_N)$. In the same time, the received information at the PU can be expressed as

$$y_p^1 = \sqrt{P_p} h_p x_p + n_{p1}, \quad (6.2)$$

where h_p is the channel between the PT and PU, n_{p1} is the additive complex Gaussian noise vector at the PU following $\mathcal{CN}(0, \sigma_{p1}^2)$.

After the ST receives the information from the PT, it amplifies the received information with the precoding. The ST superimposes the amplified information for the PU and its information with the cognitive beamforming vector for the SU. The

superimposable information can be expressed as

$$\mathbf{x}_r = \sqrt{P_p} \mathbf{W} \mathbf{h} x_p + \mathbf{W} \mathbf{n}_{r1} + \mathbf{w}_s x_s, \quad (6.3)$$

where $\mathbf{W} \in \mathbb{C}^{N \times N}$ is the precoding matrix, $\mathbf{w}_s \in \mathbb{C}^{N \times 1}$ is the cognitive beamforming vector and x_s is the information for the PU with $\mathcal{E}(|x_s|^2) = 1$.

The power of the transmitted signal at the ST is

$$P_r = P_p \|\mathbf{W} \mathbf{h}\|^2 + \sigma_{r1}^2 \|\mathbf{W}\|^2 + \|\mathbf{w}_s\|^2, \quad (6.4)$$

In the second phase, the ST uses its transmission antennas to relay the information for the PU and SU. The received signal at the PU is given by

$$y_p^2 = \sqrt{P_p} \mathbf{g}_p^H \mathbf{W} \mathbf{h} x_p + \mathbf{g}_p^H \mathbf{W} \mathbf{n}_{r1} + \mathbf{g}_p^H \mathbf{w}_s x_s + n_{p2}, \quad (6.5)$$

where $\mathbf{g}_p \in \mathbb{C}^{N \times 1}$ is the channel vector between transmission antennas of the ST and the PU and n_{p2} is additive Gaussian noise at the destination following $\mathcal{CN}(0, \sigma_{p2}^2)$.

The received signal at the SU is given by

$$y_s = \sqrt{P_p} \mathbf{g}_s^H \mathbf{W} \mathbf{h} x_p + \mathbf{g}_s^H \mathbf{W} \mathbf{n}_{r1} + \mathbf{g}_s^H \mathbf{w}_s x_s + n_s, \quad (6.6)$$

where $\mathbf{g}_s \in \mathbb{C}^{N \times 1}$ is the channel vector between transmission antennas of the ST and the PU and n_s is additive Gaussian noise at the destination following $\mathcal{CN}(\mathbf{0}, \sigma_s^2)$.

Concurrently, the ST is wirelessly powered by the PT with the dedicated energy-

bearing signal. The received signal at the ST is

$$\begin{aligned} \mathbf{y}_r^2 &= \sqrt{P_p} \mathbf{h} x_e + \mathbf{H}_r x_r + \mathbf{n}_{r2}, \\ &= \sqrt{P_p} \mathbf{h} x_e + \sqrt{P_p} \mathbf{H}_r \mathbf{W} \mathbf{h} x_p + \mathbf{H}_r \mathbf{W} \mathbf{n}_{r1} + \mathbf{H}_r \mathbf{w}_s x_s + \mathbf{n}_{r2}, \end{aligned} \quad (6.7)$$

where x_e is the transmitted signal from the PT with $\mathcal{E}(|x_e|^2) = 1$, $\mathbf{H}_r \in \mathbb{C}^{N \times N}$ is the channel matrix of the loop channel at the ST and \mathbf{n}_{r2} is the received additive complex Gaussian noise vector following $\mathcal{CN}(\mathbf{0}, \sigma_{r2}^2 \mathbf{I}_N)$. The ST not only harvests energy from the PT but also recycles part of its transmitted power due to its two groups of the antenna being activated at the same time. Unlike the other full-duplex structure studies, the full-duplex node uses interference cancellation techniques to eliminate the loop-back interference signal. In energy harvesting networks, the loop-back signal can be reused at the energy harvesting node as a part of transmitted power. The amount of the harvested energy at the ST is given by

$$\begin{aligned} E &= \frac{\eta T}{2} (P_p \|\mathbf{h}\|^2 + P_p \|\mathbf{H}_r \mathbf{W} \mathbf{h}\|^2 + \sigma_{r1}^2 \|\mathbf{H}_r \mathbf{W}\|^2 + \|\mathbf{H}_r \mathbf{w}_s\|^2 \\ &\quad + \sigma_{r2}^2), \end{aligned} \quad (6.8)$$

where η is the energy conversion efficiency coefficient at the ST. Then the total available transmitted power at the ST is $\frac{E}{T/2}$, which can be expressed as

$$\begin{aligned}
P_r^{max} = & \eta(P_p \|\mathbf{h}\|^2 + P_p \|\mathbf{H}_r \mathbf{W} \mathbf{h}\|^2 + \sigma_{r1}^2 \|\mathbf{H}_r \mathbf{W}\|^2 + \|\mathbf{H}_r \mathbf{w}_s\|^2 \\
& + \sigma_{r2}^2) + E_r^{ini},
\end{aligned} \tag{6.9}$$

where E_r^{ini} is the initial energy at the ST.

According to the signal as mentioned earlier model and applying the MRC strategy to y_p^1 and y_p^2 . The received SINR at the PU is the sum of two channel uses,

it is

$$SINR_p = \frac{P_p |h_p|^2}{\sigma_{p1}^2} + \frac{P_p |\mathbf{g}_p^H \mathbf{W} \mathbf{h}|^2}{\sigma_{r1}^2 \|\mathbf{g}_p^H \mathbf{W}\|^2 + |\mathbf{g}_p^H \mathbf{w}_s|^2 + \sigma_p^2}, \tag{6.10}$$

The achievable rate of the PU can be presented as

$$R_p = \frac{1}{2} \log_2(1 + SINR_p), \tag{6.11}$$

The received SINR at the SU is

$$SINR_s = \frac{|\mathbf{g}_s^H \mathbf{w}_s|^2}{P_p |\mathbf{g}_s^H \mathbf{W} \mathbf{h}|^2 + \sigma_{r1}^2 \|\mathbf{g}_s^H \mathbf{W}\|^2 + \sigma_s^2}, \tag{6.12}$$

The achievable rate of the SU can be presented as

$$R_s = \frac{1}{2} \log_2(1 + SINR_s), \tag{6.13}$$

6.3.2 Problem Formulation and Beamforming Design

In this section, we discuss the beamforming optimization in the considered cognitive network. Our objective is to maximize the SU's rate subject to the PU rate and transmitted power constraint by jointly optimizing the precoding and the cognitive beamforming. Particularly the addressed optimization problem is formulated as follows

$$\begin{aligned}
& \max_{\mathbf{W}, \mathbf{w}_s} R_s \\
& s. t. R_p \geq r_p, \\
& P_r \leq P_r^{max}.
\end{aligned} \tag{6.14}$$

where r_p is the minimum rate requirement for the PU. It is obvious that the problem stated above is not a standard convex problem. Then, we proposed an optimal solution based on SDP relaxation. By using the monotonicity, the original problem can be expressed as

$$\begin{aligned}
& \max_{\mathbf{W}, \mathbf{w}_s} \frac{|\mathbf{g}_s^H \mathbf{w}_s|^2}{P_p |\mathbf{g}_s^H \mathbf{W} \mathbf{h}|^2 + \sigma_{r1}^2 \|\mathbf{g}_s^H \mathbf{W}\|^2 + \sigma_s^2} \\
& s. t. \frac{P_p |h_p|^2}{\sigma_{p1}^2} + \frac{P_p |\mathbf{g}_p^H \mathbf{W} \mathbf{h}|^2}{\sigma_{r1}^2 \|\mathbf{g}_p^H \mathbf{W}\|^2 + |\mathbf{g}_p^H \mathbf{w}_s|^2 + \sigma_p^2} \geq r_p,
\end{aligned}$$

$$\begin{aligned}
& P_p \|\mathbf{W}\mathbf{h}\|^2 + \sigma_{r1}^2 \|\mathbf{W}\|^2 + \|\mathbf{w}_s\|^2 \\
& \leq \eta (P_p \|\mathbf{h}\|^2 + P_p \|\mathbf{H}_r \mathbf{W}\mathbf{h}\|^2 + \sigma_{r1}^2 \|\mathbf{H}_r \mathbf{W}\|^2 \\
& \quad + \|\mathbf{H}_r \mathbf{w}_s\|^2 + \sigma_{r2}^2) + P_r^{ini}. \tag{6.15}
\end{aligned}$$

In the above problem, the precoding matrix \mathbf{W} can be characterized as $\mathbf{W} = \mathbf{w}_p \mathbf{h}^H$. It can be proved this structure is the optimal structure of \mathbf{W} [103]. This structure amplifies the received signal from the PT employing \mathbf{h}^H to produce a noisy version of the primary information and forward the information with the beamforming \mathbf{w}_p . It also simplifies the above problem. Therefore, the problem can be further expressed as

$$\begin{aligned}
& \max_{\mathbf{w}_p, \mathbf{w}_s} \frac{|\mathbf{g}_s^H \mathbf{w}_s|^2}{(P_p \|\mathbf{h}\|^4 + \sigma_{r1}^2 \|\mathbf{h}\|^2) |\mathbf{g}_s^H \mathbf{w}_p|^2 + \sigma_s^2} \\
& \text{s. t. } (P_p \|\mathbf{h}\|^4 - r_p \sigma_{r1}^2 \|\mathbf{h}\|^2) |\mathbf{g}_p^H \mathbf{w}_p|^2 - r_p |\mathbf{g}_p^H \mathbf{w}_s|^2 \geq \bar{r}_p \sigma_p^2, \\
& \quad (P_p \|\mathbf{h}\|^4 + \sigma_{r1}^2 \|\mathbf{h}\|^2) (\|\mathbf{w}_p\|^2 - \eta \|\mathbf{H}_r \mathbf{w}_p\|^2) + \|\mathbf{w}_s\|^2 \\
& \quad - \eta \|\mathbf{H}_r \mathbf{w}_s\|^2 \leq \eta P_p \|\mathbf{h}\|^2 + \eta \sigma_{r2}^2 + P_r^{ini}. \tag{6.16}
\end{aligned}$$

where $\bar{r}_p = r_p - \frac{P_p |h_p|^2}{\sigma_{p1}^2}$. Define a new variable $\mathbf{X} = \mathbf{w}_p \mathbf{w}_p^H$ and $\mathbf{Y} = \mathbf{w}_s \mathbf{w}_s^H$, the

optimization problem can be reformulated as

$$\max_{\mathbf{X} \succeq \mathbf{0}, \mathbf{Y} \succeq \mathbf{0}} \frac{\text{Tr}(\mathbf{Q}_1 \mathbf{X})}{\text{Tr}(\mathbf{Q}_2 \mathbf{X}) + \sigma_s^2}$$

$$s. t. Tr(\mathbf{Q}_3\mathbf{X}) - Tr(\mathbf{Q}_4\mathbf{Y}) \geq \bar{r}_p \sigma_p^2,$$

$$Tr(\mathbf{Q}_5\mathbf{X}) + Tr(\mathbf{Q}_6\mathbf{Y}) \leq \eta P_p \|\mathbf{h}\|^2 + \eta \sigma_{r_2}^2 + P_r^{ini},$$

$$Rank(\mathbf{X}) = 1,$$

$$Rank(\mathbf{Y}) = 1. \tag{6.17}$$

where $\mathbf{Q}_1 = \mathbf{g}_s \mathbf{g}_s^H$, $\mathbf{Q}_2 = (P_p \|\mathbf{h}\|^4 + \sigma_{r_1}^2 \|\mathbf{h}\|^2) \mathbf{g}_s \mathbf{g}_s^H$, $\mathbf{Q}_3 = (P_p \|\mathbf{h}\|^4 - r_p \sigma_{r_1}^2 \|\mathbf{h}\|^2) \mathbf{g}_p \mathbf{g}_p^H$, $\mathbf{Q}_4 = r_p \mathbf{g}_p \mathbf{g}_p^H$, $\mathbf{Q}_5 = (P_p \|\mathbf{h}\|^4 + \sigma_{r_1}^2 \|\mathbf{h}\|^2) (\mathbf{I} - \eta \mathbf{H}_r^H \mathbf{H}_r)$ and $\mathbf{Q}_6 = \mathbf{I} - \eta \mathbf{H}_r^H \mathbf{H}_r$.

It can be seen that the rank-one constraint makes the problem still difficult to solve.

Therefore, we drop the rank-one constraint and then the above problem is a quasi-convex problem because that the problem's objective function has a fractional structure. Instead of employing the bisection search approach, we use the Charnes-Cooper transformation [91] to solve it. Specifically, we define a new variable

$t = \frac{1}{Tr(\mathbf{Q}_2\mathbf{X}) + \sigma_s^2}$ and let $\tilde{\mathbf{X}} = t\mathbf{X}$, $\tilde{\mathbf{Y}} = t\mathbf{Y}$. The problem can be recast as follows

$$\max_{\tilde{\mathbf{X}} \succeq \mathbf{0}, \tilde{\mathbf{Y}} \succeq \mathbf{0}, t} Tr(\mathbf{Q}_1 \tilde{\mathbf{Y}})$$

$$s. t. Tr(\mathbf{Q}_2 \tilde{\mathbf{X}}) + t \sigma_s^2 = 1,$$

$$Tr(\mathbf{Q}_3 \tilde{\mathbf{X}}) - Tr(\mathbf{Q}_4 \tilde{\mathbf{Y}}) \geq t \bar{r}_p \sigma_p^2,$$

$$Tr(\mathbf{Q}_5\tilde{\mathbf{X}}) + Tr(\mathbf{Q}_6\tilde{\mathbf{Y}}) \leq t\eta P_p \|\mathbf{h}\|^2 + t\eta\sigma_{r2}^2 + tP_r^{ini}. \quad (6.18)$$

Then the problem is a standard SDP problem, and one can efficiently find its optimal solution via available solvers [92]. The optimal solution is denoted by $\tilde{\mathbf{X}}^*$, $\tilde{\mathbf{Y}}^*$ and t^* . Then the solution of \mathbf{X} denoted by \mathbf{X}^* is obtained by $\mathbf{X}^* = \frac{\tilde{\mathbf{X}}^*}{t^*}$, and the solution of \mathbf{Y} denoted by \mathbf{Y}^* is obtained by $\mathbf{Y}^* = \frac{\tilde{\mathbf{Y}}^*}{t^*}$. If \mathbf{X}^* and \mathbf{Y}^* are rank one, \mathbf{w}_p and \mathbf{w}_s can be exactly computed via eigenvalue decomposition. Otherwise, we can use the SBP rank reduction theorem which is obtained from the result in [93] to obtain the rank-one solution.

It is necessary to mention that we can use the power splitting relaying protocol as the benchmark scheme compared with the self-energy recycling scheme. Our method to optimize the beamforming with the self-energy recycling protocol is easily extended to the power splitting relaying protocol. Hence, we omit its detailed procedure here, and we provide its simulation result in the next section.

6.4 Numerical Results

In this section, simulation results are provided to evaluate the performance of the proposed beamforming optimization solution. The number of antenna is 3. We use the TGN path loss model [101]. The loop channel path loss is -15 dB [102]. The channel vectors are randomly generated from independent and identically distributed Rayleigh Rician random variables with Rician factor 6dB. The initial power at the ST is 10 dBm. The minimum requirement rate of the PU is 3 bps/Hz. The distance between each node is set as 10 m. The system bandwidth is 200 kHz. The carrier frequency is 470 MHz, which is accorded with the IEEE 802.11af Wi-Fi parameters [95]. The noise variance is assumed as $\sigma_{r1}^2 = \sigma_{r2}^2 = \sigma_{p1}^2 = \sigma_{p2}^2 = \sigma_s^2 = -25$ dBm. The energy conversion efficient is 0.8. Simulation results were averaged over 1000 independent trials.

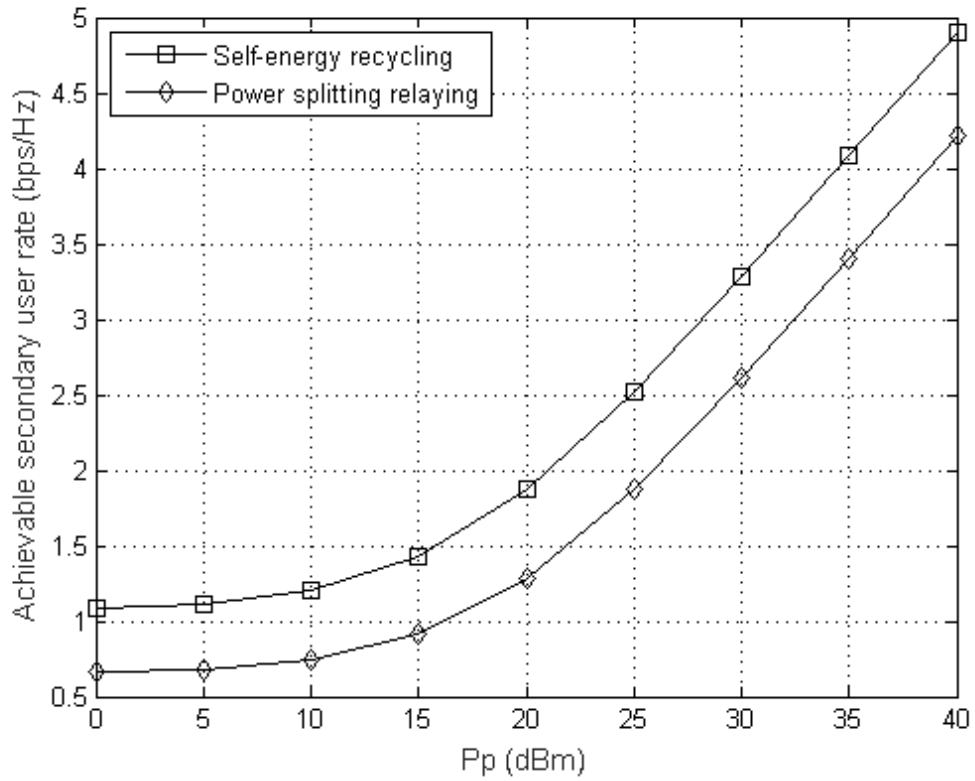

Figure 6.2: Achievable SU's rate versus transmitted power at the PT for different energy harvesting protocols.

In Fig. (6.2), the achievable SU's rate achieved by different energy harvesting protocols versus the transmitted power at the PT are plotted. The result for the self-energy recycling protocol is demonstrated and the result for the power splitting relaying protocol are also shown as benchmarks. The result for the power splitting relaying protocol is obtained with their optimal energy harvesting coefficient. It can be seen that curves of achievable SU's rate for these energy harvesting protocols are

monotonically non-decreasing functions of the transmitted power at the PT because the higher transmitted power results in more available power at the ST for the broadcasting transmission. The self-energy recycling protocol outperforms the power splitting relaying protocol. This is because that the full-duplex structure used in the self-energy recycling relaying protocol not only harvests the power transmitted from the PT but also recycles the part of transmitted power at the ST. Compared to the power splitting relaying protocol, the self-energy harvesting protocol achieves an obvious rate gain. The self-energy recycling protocol has better performance than the other energy harvesting protocol.

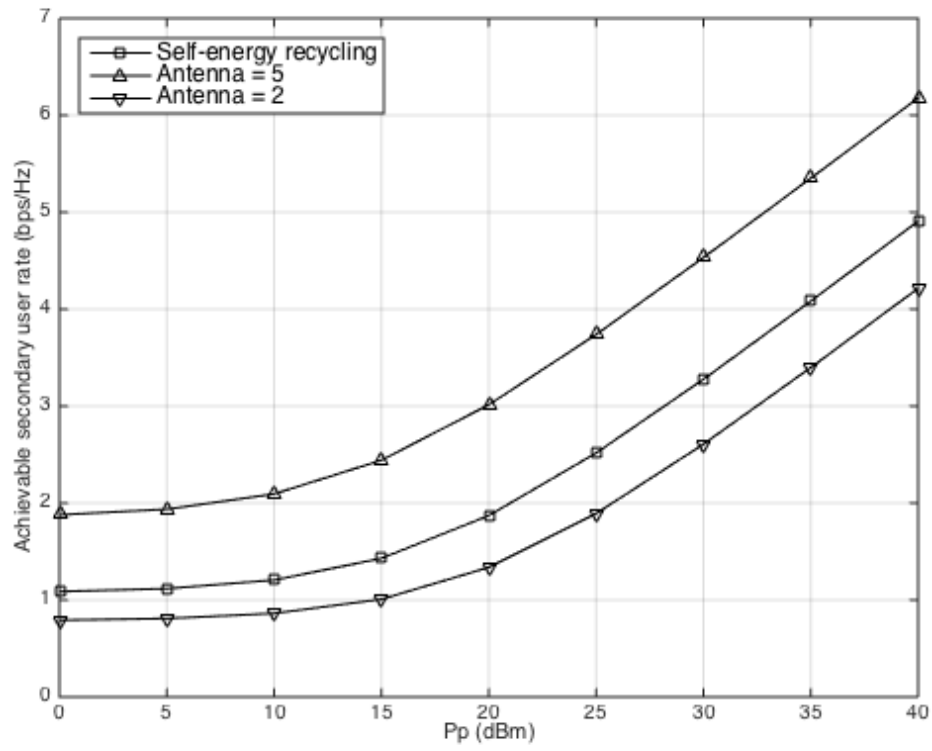

Figure 6.3: Achievable SU's rate versus transmitted power at the PT for self-energy recycling relaying protocol with different numbers of antenna.

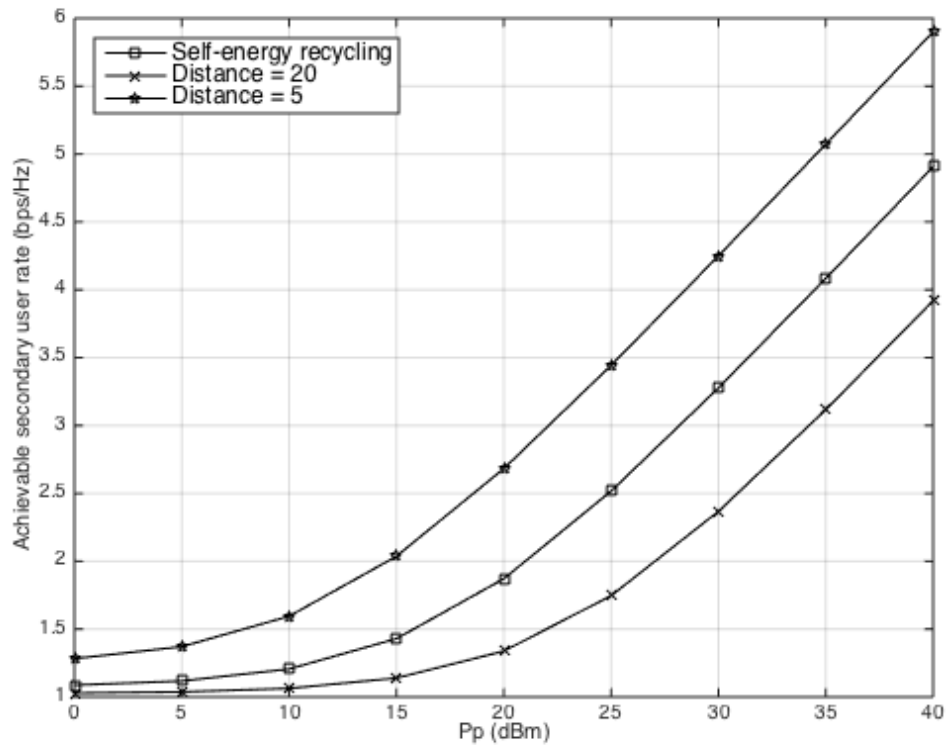

Figure 6.4: Achievable SU's rate versus transmitted power at the PT for self-energy recycling relaying protocol with different distances.

In Fig. (6.3) and Fig. (6.4), we present the achievable SU's rate versus the transmitted power at the PT for the self-energy recycling relaying protocol with different system parameters. It can be seen from the figure that the achievable SU's rate improves with the increased number of the antenna and is degraded with the increase of the distance between each node. This is attributed to the fact that the ST could exploit the array gain to achieve better performance with more antennas, and the

longer distance makes channel attenuation larger in turns resulting in, the worse performance.

6.5 Chapter Summary

In this chapter, we formulated the beamforming optimization problem in a cooperative cognitive radio network based on the self-energy recycling relaying protocol. We proposed a SDP-based solution to obtain the optimal solution for the proposed problem. To demonstrate the advantage of the self-energy recycling relaying protocol, we also used the SDP relaxation and 1-D optimization to solve the beamforming optimization problem the power splitting relaying protocol. Simulation results illustrated that the self-energy recycling relaying protocol could improve the achievable SU's rate compared to the power splitting relaying protocol. The trade-off between the achievable SU's rate and system parameters is also provided.

Chapter 7

Conclusion and Future Works

7.1 Conclusion

In this thesis, the wireless energy harvesting technique and some optimization studies regarding applications of the wireless energy harvesting in different communication networks are investigated. For optimization problems proposed in the thesis, we develop mathematical algorithms to find optimal solutions, and simulation results are provided to verify the effectiveness of solutions.

In the first Chapter, an overview of wireless energy harvesting is introduced. In the past, the initial idea of wireless energy harvesting was not practical to implement due to the low energy efficiency. Recently, the development of circuit technology and an increasing number of the low-powered electronic device make the wireless energy harvesting attracts more and more attention from both academic and industry fields.

In Chapter 2, the background of wireless energy harvesting is presented. The architecture of wireless energy harvesting network, the introduction of the different power source and practical applications of wireless energy harvesting are discussed. Also, an important energy harvesting technique used in communication networks is introduced, which refers as SWIPT. SWIPT is that the network node uses the same antenna module to perform receiving information and harvesting energy. Nevertheless, due that the existing circuit has some practical issues to simultaneously processing the information reception and energy harvesting, some structures of the communication network node are proposed to achieve the practical implementation of SWIPT.

Chapter 3 focused on an energy-efficient optimization in the cooperative network with wireless information and power transfer. The energy harvesting technique is used at the relay node in a DF cooperative network. Based on the time switching relaying protocol and power splitting relaying protocol, optimization problems of energy efficiency are formulated. The formulated problems can be re-constructed into a convex form by using the nonlinear fractional programming, to which closed form solutions can be found by using the Lagrange multiplier method. Simulation results

are presented in this chapter to verify the effectiveness of this solution.

In chapter 4, the secure communication in the cooperative network with wireless information and power transfer is discussed. The secure communication issue is considered in an AF cooperative network with an energy harvesting relay node. Based on the time switching relaying protocol and power splitting relaying protocol, the problem for maximizing the secrecy rate subject to the transmitted power and energy harvesting coefficient is proposed. To find the optimal solution, SDP relaxation, and 1-D optimization are used. Simulation results are presented to show the system performance for two energy harvesting protocols.

A self-energy recycling protocol is proposed in chapter 5. Based on this energy harvesting protocol, we study the beamforming optimization problem in an energy harvesting cooperative full-duplex network. The problem is to maximize the achievable rate subject to the available transmitted power at the relay node. The SDP method is used to solve the problem. For comparison, we also propose a beamforming optimization problem based on the time switching relaying protocol. The self-energy recycling protocol can achieve a significant rate gain compared to the other energy

harvesting protocol.

In chapter 6, we use the self-energy recycling protocol in a full-duplex cooperative cognitive radio network. In considered network, the channel of the primary system is affected with deep fading or shadowing effects, the ST harvests energy from the PT and assists the primary information transmission. The ST has a full-duplex structure and employs the self-energy recycling protocol. The problem aims to maximize the achievable SU's rate subject to the available transmitted power at the ST and minimum rate requirement for the PU. The system performance with the self-energy recycling protocol is compared to it with the other energy harvesting protocol in the simulation.

7.2 Future Works

It is recommended that further research be undertaken in the following areas:

For the energy efficiency study in the wireless energy harvesting network, it is potential to extend the work in the thesis into the more complex communication

network with SWIPT, such as multi-user relaying network with AF or DF relaying protocol. And it is excited to study the energy efficiency algorithm with the convex optimization in the multi-antenna network with energy harvesting, such as MIMO or MISO.

For the secure communication with SWIPT, it is possible to extend the SDP method into the MIMO network. And it is also interesting to study the more complex security issue with energy harvesting, such as the network with jammers or the untrusted relay node. The convex technique for the secure issue can also be investigated more in the future.

In the full-duplex network model, there will be more interesting problem. The full-duplex structure provides the self-recycling energy harvesting protocol compared to the half-duplex model, which brings more different resource allocation convex problems that could be optimized in many communication networks.

Appendix

In the appendix, the convergence of proposed algorithm in Chapter 3 regarding transformed parametric problems is proved. First of all, we introduce two lemmas.

Lemma 1. *The object function $C - q^*E_c$ is a monotonic decreasing function of q^* .*

Proof. Given two power allocation results in P_{sa} and P_{sb} with their corresponding energy efficiency q_a^* and q_b^* . We define $q_a^* > q_b^*$, then we have

$$\begin{aligned} & \max_{P_s} C - q_b^*E_c \\ &= C(P_{sb}) - q_b^*E_c(P_{sb}) \\ &> C(P_{sa}) - q_b^*E_c(P_{sa}) \\ &\geq C(P_{sa}) - q_a^*E_c(P_{sa}) \\ &= \max_{P_s} C - q_a^*E_c, \quad \blacksquare \end{aligned}$$

Lemma 2. *There is an energy efficiency solution q^* to ensure $C - q^*E_c = 0$.*

Proof. It can be proved that the objective function is continuous in q^* . If q^* is plus infinity, the value of the objective function is minus infinity and vice-versa. Hence,

there is a q^* to let $C - q^*E_c = 0$. ■

With the above lemmas, we can prove the convergence of the transformed parametric problem. We denote P_{sn} and q_n^* as the energy efficiency policy in the n -th iteration. Recall that in the algorithm, $q_{n+1}^* = \frac{C(P_{sn})}{E_c(P_{sn})}$. Then we have

$$\begin{aligned} & C(P_{sn}) - q_n^*E_c(P_{sn}) \\ &= q_{n+1}^*E_c(P_{sn}) - q_n^*E_c(P_{sn}) \\ &= (q_{n+1}^* - q_n^*)E_c(P_{sn}), \end{aligned}$$

where $E_c(P_{sn})$ is greater than 0, therefore, $q_{n+1}^* - q_n^* \geq 0$, The q_n^* is non-decreasing in the iterative process. In Lemma 1, the objective function is monotonically decreasing in q_n^* and q_n^* is non-decreasing in the iteration. Therefore, the objective function is non-increasing in the iteration. In Lemma 2, the optimum energy efficiency converges when $C - q^*E_c = 0$. If the iteration index is large enough, $C - q^*E_c$ will equal to 0. Moreover, the optimal energy efficiency will be obtained.

References

- [1] H. J. Visser and R. J. Vullers, "RF energy harvesting and transport for wireless sensor network applications: Principles and requirements," in *Proceedings of the IEEE*, June 2013, pp. 1410-1423.
- [2] A. Sample and J. R. Smith, "Experimental results with two wireless power transfer systems," in *Proc. IEEE Radio and Wireless Symposium (RWS)*, San Diego, USA, Jan. 2009.
- [3] H. Nishimoto, Y. Kawahara, and T. Asami, "Prototype implementation of ambient RF energy harvesting wireless sensor networks," in *Proceedings of IEEE Sensors*, Kona, Hawaii, USA, November 2010.
- [4] X. Zhang, H. Jiang, L. Zhang, C. Zhang, Z. Wang, and X. Chen, "An energy-efficient ASIC for wireless body sensor networks in medical applications," *IEEE Transactions on Biomedical Circuits and Systems*, vol. 4, no. 1, pp. 11-18, February 2010.
- [5] N. Shinohara, "Development of rectenna with wireless communication system,"

in *Proc. European Conf. Ant. Prop.*, Rome, Italy, April 2011, pp. 3970-3973.

- [6] R. Zhang and C. K. Ho, "MIMO broadcasting for simultaneous wireless information and power transfer," *IEEE Trans. Wireless Commun.*, vol. 12, no. 5, pp. 1989-2001, May 2013.
- [7] W. C. Brown, "Experiments involving a microwave beam to power and position a helicopter," *IEEE Trans. Aerosp. Electron. Syst.*, vol. AES-5, no. 5, pp. 692-702, Sep. 1969.
- [8] J. O. Mcspadden and J. C. Mankins, "Space solar power programs and microwave wireless power transmission technology," *IEEE Microw. Mag.*, vol. 3, no. 4, pp. 46-57, Apr. 2002.
- [9] K. Huang and V. K. N. Lau, "Enabling wireless power transfer in cellular networks: Architecture, modeling and deployment," *IEEE Trans. Wireless Commun.*, vol. 13, no. 2, pp. 902-912, Feb. 2014.
- [10] L. Liu, R. Zhang, and K. C. Chua, "Multi-antenna wireless powered communication with energy beamforming," *IEEE Trans. Commun.*, vol. 62, no. 12, pp. 4349-4361, Dec. 2014.

- [11] X. Chen, X. Wang, and X. Chen, "Energy-efficient optimization for wireless information and power transfer in large-scale MIMO systems employing energy beamforming," *IEEE Wireless Commun. Lett.*, vol. 2, no. 6, pp. 667-670, Dec. 2013.
- [12] Z. Popovic, "Cut the cord: Low-power far-field wireless powering," *IEEE Microw. Mag.*, vol. 14, no. 2, pp. 55-62, 2013.
- [13] Powercast. [Online]. Available: www.powercastco.com
- [14] M. Erol-Kantarci and H. T. Mouftah, "Suresense: Sustainable wireless rechargeable sensor networks for the smart grid," *IEEE Wireless Commun.*, vol. 19, no. 3, pp. 30-36, Jun. 2012.
- [15] M. Erol-Kantarci and H. T. Mouftah, "Mission-aware placement of RF-based power transmitters in wireless sensor networks," in *Proc. ISCC*, Cappadocia, Turkey, Jul. 2012, pp. 12-17.
- [16] M. Erol-Kantarci and H. T. Mouftah, "DRIFT: differentiated RF power transmission for wireless sensor network deployment in the smart grid," in *Proc. IEEE Globecom Workshops*, Anaheim, CA, USA, Dec. 2012, pp.

1491-1495.

- [17] I. Flint, X. Lu, N. Privault, D. Niyato, and P. Wang, "Performance analysis of ambient RF energy harvesting: A stochastic geometry approach," in *Proc. IEEE GLOBECOM*, Austin, TX, USA, Dec. 2014, pp. 1-6.
- [18] S. Lee, R. Zhang, and K. Huang, "Opportunistic wireless energy harvesting in cognitive radio networks," *IEEE Transactions on Wireless Communications*, vol. 12, no. 9, pp. 4788-4799, September 2013.
- [19] K. Kaushil, D. Mishra, S. De, S. Basagni, W. Heinzelman, K. Chowdhury, and S. Jana, "Experimental demonstration of multi-hop RF energy transfer," in *Proc. IEEE Int. Symp. PIMRC*, London, U.K., Sep. 2013, pp. 538-542.
- [20] J. P. Olds and W. K. G. Seah, "Design of an active radio frequency powered multi-hop wireless sensor network," in *Proc. ICIEA*, Singapore, Jul. 2012, pp. 1721-1726.
- [21] W. K. G. Seah and J. P. Olds, "Data delivery scheme for wireless sensor network powered by RF energy harvesting," in *Proc. IEEE WCNC*, Shanghai, China, Apr. 2013, pp. 1498-1503.

- [22] Y. Zuo, "Survivable RFID systems: Issues, challenges, and techniques," *IEEE Trans. Syst., Man, Cybern. C, Appl. Rev.*, vol. 40, no. 4, pp. 406-418, Jul. 2010.
- [23] U. Olgun, C. C. Chen, and J. L. Volakis, "Low-profile planar rectenna for batteryless RFID snesors," in *Proc. IEEE APSURSI*, Toronto, ON, USA, Jun. 2010, pp. 1-4.
- [24] H. Jabbar, Y. S. Song, and T. T. Jeong, "RF energy harvesting system and circuits for charging of mobile devices," *IEEE Trans. Consum. Electron.*, vol. 56, no. 1, pp. 247-253, Feb. 2010.
- [25] L. R. Varshney, "Transporting information and energy simultaneously," in *Proceedings of IEEE International Symposium on Information Theory*, Toronto, Ontario, Canada, July 2008, pp. 1612-1616.
- [26] X. Zhou, R. Zhang, and C. K. Ho, "Wireless information and power transfer: Architecture design and rate-energy tradeoff," *IEEE Trans. Commun.*, vol. 61, no. 11, pp. 4757-4767, Nov. 2013.
- [27] P. Grover and A. Sahai, "Shannon meets Tesla: Wireless information and power transfer," in *Proc. IEEE ISIT*, Austion, TX, USA, Jun. 2010, pp.

2363-2367.

- [28] A. M. Fouladgar and O. Simeone, "On the transfer of information and energy in multi-user systems," *IEEE Commun. Lett.*, vol. 16, no. 11, pp. 1733-1736, Nov. 2012.
- [29] P. Popovski, A. M. Fouladgar, and O. Simeone, "Interactive joint transfer of energy and information," *IEEE Trans. Commun.*, vol. 61, no. 5, pp. 2086-2097, May 2013.
- [30] I. Krikidis, S. Sasaki, S. Timotheou, and Z. Ding, "A low complexity antenna switching for joint wireless information and energy transfer in MIMO relay channels," *IEEE Trans. commun.*, vol. 62, no. 5, pp. 1577-1587, May 2014.
- [31] D. W. K. Ng, E. S. Lo, and R. Schober, "Robust beamforming for secure communication in systems with wireless information and power transfer," *IEEE Trans. Wireless Commun.*, vol. 13, no. 8, pp. 4599-4615, Apr. 2014.
- [32] D. W. K. Ng, E. S. Lo, and R. Schober, "Wireless information and power transfer: Energy efficiency optimization in OFDMA systems," *IEEE Trans. Wireless Commun.*, vol. 12, no. 12, pp. 6352-6370, Dec. 2013.

- [33] L. Liu, R. Zhang, and K. C. Chua, "Wireless information transfer with opportunistic energy harvesting," *IEEE Trans. Wireless Commun.*, vol. 12, no. 1, pp. 288-300, Jan. 2013.
- [34] L. Liu, R. Zhang, and K. C. Chua, "Wireless information and power transfer: A dynamic power splitting approach," *IEEE Trans. Commun.*, vol. 61, no. 9, pp. 3990-4001, Sept. 2013.
- [35] X. Zhou, "Training-based SWIPT: Optimal power splitting at the receiver," *IEEE Trans. Veh. Technol.*, vol. 64, no. 9, 2015.
- [36] D. W. K. Ng, E. S. Lo, and R. Schober, "Spectral efficient optimization in OFDM systems with wireless information and power transfer," in *Proc. IEEE EUSIPCO*, Marrakech, Morocco, Sep. 2013, pp. 1-5.
- [37] D. W. K. Ng, E. S. Lo, and R. Schober, "Energy-efficient power allocation in OFDM systems with wireless information and power transfer," in *Proc. IEEE ICC*, Budapest, Hungary, Jun. 2013, pp. 4125-4130.
- [38] X. Zhou, R. Zhang, and C. K. Ho, "Wireless information and power transfer in multiuser OFDM systems," *IEEE Trans. Wireless Commun.*, vol. 13, no. 4, pp.

2282-2294, Apr. 2014.

- [39] X. Chen, X. Wang, and X. Chen, "Energy-efficient optimization for wireless information and power transfer in large-scale MIMO systems employing energy beamforming," *IEEE Wireless Communications Letters*, vol. 2, no. 6, pp. 667-670, Dec. 2013.
- [40] K. Huang and E. Larsson, "Simultaneous information and power transfer for broadband wireless systems," *IEEE Trans. Signal Process.*, vol. 61, no. 23, pp. 5972-5986, Dec. 2013.
- [41] W. C. Brown, "The history of power transmission by radio waves," *IEEE Trans. Microw. Theory Tech.*, vol. 32, no. 9, pp. 1230-1242, Sep. 1984.
- [42] Z. Xiang and M. Tao, "Robust beamforming for wireless information and power transmission," *IEEE Wireless Commun. Lett.*, vol. 1, no. 4, pp. 372-375, Aug. 2012.
- [43] H. Zhang, K. Song, Y. Huang, and L. Yang, "Energy harvesting balancing technique for robust beamforming in multiuser MISO SWIPT system," in *Proc. IEEE Int. Conf. WCSP*, Hangzhou, China, Oct. 2013.

- [44] J. Xu, L. Liu, and R. Zhang, "Multiuser MISO beamforming for simultaneous wireless information and power transfer," *IEEE Trans. Signal Process.*, vol. 62, no. 18, pp. 4798-4810, Sep. 2014.
- [45] M. R. A. Khandaker and K. K. Wong, "SWIPT in MISO Multicasting Systems," *IEEE Wireless Commun. Lett.*, vol. 3, no. 3, pp. 277-280, Jun. 2014.
- [46] B. Koo and D. Park, "Interference alignment and wireless energy transfer via antenna selection," *IEEE Commun. Lett.*, vol. 18, no. 4, pp. 548-551, Apr. 2014.
- [47] W. Wang, L. Li, Q. Sun, and J. Jin, "Power allocation in multiuser MIMO systems for simultaneous wireless information and power transfer," in *Proc. IEEE Veh. Technol. Conf. (VTC)*, Las Vegas, USA, Sept. 2013.
- [48] S. Timotheou, I. Krikidis, G. Zheng, and B. Ottersten, "Beamforming for MISO interference channels with QoS and RF energy transfer," *IEEE Trans. Wireless Commun.*, vol. 13, no. 5, pp. 2646-2658, May 2014.
- [49] J. Park and B. Clerckx, "Joint wireless information and energy transfer in a two-user MIMO interference channel," *IEEE Trans. Wireless Commun.*, vol.

12, no. 8, pp. 4210-4221, Aug. 2013.

- [50] J. Park and B. Clerckx, "Joint wireless information and energy transfer in a k-user MIMO interference channel," *IEEE Trans. wireless Commun.*, vol. 13, no. 10, pp. 5781-5796, Oct. 2014.
- [51] D. W. K. Ng and R. Schober, "Resource allocation for coordinated multipoint networks with wireless information and power transfer," in *Proc. IEEE GLOBECOM*, Austin, TX, USA, Dec. 2014, pp. 1-7.
- [52] L. Liu, R. Zhang, and K. C. Chua, "Secrecy wireless information and power transfer with MISO beamforming," *IEEE Trans. Signal Process.*, vol. 62, no. 7, pp. 1850-1863, Apr. 2014.
- [53] Q. Shi, W. Xu, J. Wu, E. Song, and Y. Wang, "Secure beamforming for MIMO broadcasting with wireless information and power transfer," *IEEE trans. Wireless Commun.*, vol. 14, no. 5, pp. 2841-2853, May 2015.
- [54] D. W. K. Ng, E. S. Lo, and R. Schober, "Multi-objective resource allocation for secure communication in cognitive radio networks with wireless information and power transfer," *IEEE Trans. Veh. Technol.*, vol. PP, no. 99, pp.

1, May 2015.

- [55] J. N. Laneman, D. N. C. Tse, and G. W. Wornell, "Cooperative diversity in wireless networks: efficient protocols and outage behavior," *IEEE Trans. Inf. Theory*, vol. 50, no. 12, pp. 3062-3080, Dec. 2004.
- [56] J. N. Laneman, G. W. Wornell, and D. N. C. Tse, "An Efficient Protocol for Realizing Cooperative Diversity in Wireless Networks," in *Proc. IEEE ISIT*, Washington, DC, June 2001.
- [57] A. Meier, *Cooperative Diversity in Wireless Networks*. MSc Thesis, University of Edinburgh, 2004.
- [58] K. Ishibashi and H. Ochiai, "Analysis of instantaneous power distributions for non-regenerative and regenerative relaying signals," *IEEE Trans. Wireless Commun.*, vol. 11, no. 1, pp. 258-265, Jan. 2012.
- [59] I. Krikidis, S. Timotheou, and S. Sasaki, "RF energy transfer for cooperative networks: Data relaying or energy harvesting?," *IEEE Commun. Lett.*, vol. 16, no. 11, pp. 1772-1775, Nov. 2012.
- [60] A. A. Nasir, X. Zhou, S. Durrani, and R. A. Kennedy, "Relaying protocols for

- wireless energy harvesting and information processing,” *IEEE Trans. Wireless Commun.*, vol. 12, no. 7, pp. 3622-3636, Jul. 2013.
- [61] A. A. Nasir, X. Zhou, S. Durrani, and R. A. Kennedy, “Wireless energy harvesting and information relaying: Adaptive time-switching protocols and throughput analysis,” *IEEE Trans. Commun.*, vol. 63, no. 5, pp. 1607-1622, May 2015.
- [62] Z. Ding and H. V. Poor, “User scheduling in wireless information and power transfer networks,” in *Proc. IEEE Int. Conf. on Commun. Systems (ICCS)*, Macau, China, Nov. 2014.
- [63] Z. Ding, S. M. Perlaza, I. Esnaola, and H. V. Poor, “Power allocation strategies in energy harvesting wireless cooperative networks,” *IEEE Trans. Wireless Commun.*, vol. 13, no. 2, pp. 846-860, Feb. 2014.
- [64] K. Tutuncuoglu and A. Yener, “Cooperative energy harvesting communications with relaying and energy sharing,” in *Proc. IEEE ITW*, Sevilla, Spain, Sep. 2013, pp. 1-5.
- [65] B. Gurakan, O. Ozel, J. Yang, and S. Ulukus, “Two-way and multiple access

- energy harvesting systems with energy cooperation,” in *Proc. of IEEE Conference Record of the Forty Sixth Asilomar Conference on Signals, Systems and Computers (ASILOMAR)*, Pacific Grove, CA, USA, Nov. 2012, pp. 58-62.
- [66] Z. Chen, B. Xia, and H. Liu, “Wireless energy harvesting and power transfer in two-way amplify-and-forward relaying channels,” in *IEEE Global Conference*, Atlanta, GA, Dec, 2014, pp. 168-172.
- [67] D. Li, C. Shen, and Z. Qiu, “Two-way relay beamforming for sum-rate maximization and energy harvesting,” in *Proc. IEEE ICC*, Budapest, Hungary, Jun. 2013, pp. 3115-3120.
- [68] D. Li, C. Shen, and Z. Qiu, “Sum rate maximization and energy harvesting for two-way AF relay systems with imperfect CSI,” in *Proc. IEEE ICASSP*, Vancouver, BC, Canada, May 2013, pp. 4958-4962.
- [69] D. W. K. Ng, E. Lo, and R. Schober, “Energy-efficient resource allocation in OFMDA systems with large numbers of base station antennas,” *IEEE Trans. Wireless Commun.*, vol. 11, no. 9, pp. 3292 - 3304, Sep. 2012.
- [70] T. Chen, Y. Yang, H. Zhang, H. Kim, and K. Horneman, “Network energy

- saving technologies for green wireless access networks,” *IEEE Wireless Commun.*, vol. 18, no. 5, pp. 30-38, Oct. 2011.
- [71] F. Chu, K. Chen, and G. Fettweis, “Green resource allocation to minimize receiving energy in OFDMA cellular systems,” *IEEE Commun. Lett.*, vol. 16, no. 3, pp. 372-374, Jan. 2012.
- [72] K. Pentikousis, “In search of energy-efficient mobile networking,” *IEEE Commun. Mag.*, vol. 48, no. 1, pp. 95-103, Jan. 2010.
- [73] O. Arnold, F. Richter, G. Fettweis, and O. Blume, “Power consumption modeling of different base station types in heterogeneous cellular networks,” in *Proc. 2010 Future Network and Mobile Summit*, Florence, 2010, pp. 1-8.
- [74] J. Yang and S. Ulukus, “Optimal packet scheduling in an energy harvesting communication system,” *IEEE Trans. Commun.*, vol. 60, no. 1, pp. 220-230, Jan. 2012.
- [75] W. Dinkelbach, “On nonlinear fractional programming,” *Management Science*, vol. 13, no. 9, pp. 492-498, Mar. 1967.
- [76] A. D. Wyner, “The wire-tap channel ” *The Bell System Technical Journal*, vol.

54, no. 8, pp. 1355 - 1387, Oct. 1975.

- [77] S. Goel and R. Negi, "Guaranteeing secrecy using artificial noise," *Ieee Trans. Wireless Commun.*, vol. 7, no. 6, pp. 2180-2189, Jun. 2008.
- [78] D. W. K. Ng, E. S. Lo, and R. Schober, "Secure resource allocation and scheduling for OFDMA decode-and-forward relay networks," *IEEE Trans. Wireless Commun.*, vol. 10, no. 10, pp. 3528 - 3540, Oct. 2011.
- [79] Y. Liang, H. Poor, and S. Shamai, "Secure communication over fading channels," *IEEE Transactions on Information Theory, Special Issue on Information Theoretic Security*, vol. 54, no. 6, pp. 2470–2492, Jun. 2008.
- [80] S. Shabnam and S. Ulukus, "Achievable rates in gaussian MISO channels with secrecy constraints," *IEEE conference on Information Theory*, pp. 2466 - 2470, Jun. 2007.
- [81] S. Shabnam, N. Liu, and S. Ulukus, "Towards the secrecy capacity of the gaussian MIMO wire-tap channel: The 2-2-1 channel," *IEEE Transactions on Information Theory*, vol. 55, no. 9, pp. 4033-4039, Sep. 2008.
- [82] L. Dong, Z. Han, and A. P. Petropulu, "Improving wireless physical layer

- security via cooperating relays,” *IEEE Trans. Signal Process.*, vol. 58, no. 3, pp. 1875-1888, Mar. 2010.
- [83] J. Zhang and M. C. Gursoy, “Relay beamforming strategies for physical-layer security,” in *Proc. 44th Annual Conference on Information Sciences and Systems*, Mar. 2010, pp. 1-6.
- [84] Y. Yang, Q. Li, W.-K. Ma, J. Ge, and P. C. Ching, “Cooperative secure beamforming for af relay networks with multiple eavesdroppers,” *IEEE Signal Process. Lett.*, vol. 20, no. 1, pp. 35-38, Jan. 2013.
- [85] J. Li, A. P. Petropulu, and S. Weber, “On cooperative relaying schemes for wireless physical layer security,” *IEEE Trans. Signal Process.*, vol. 59, no. 10, pp. 4985–4997, Oct. 2011.
- [86] D. W. K. Ng and R. Schober, “Resource allocation for secure communication in systems with wireless information and power transfer,” in *Globecom Workshops (GC Wkshps), 2013 IEEE*, Atlanta, GA, Dec. 2013, pp. 1251 - 1257.
- [87] D. W. K. Ng, L. Xiang, and R. Schober, “Multi-objective beamforming for

- secure communication in systems with wireless information and power transfer,” in *Personal Indoor and Mobile Radio Communications (PIMRC), 2013 IEEE 24th International Symposium on*, London, Sept. 2013, pp. 7 - 12.
- [88] Q. Li, Q. Zhang, and J. Qin, “Secure relay beamforming for simultaneous wireless information and power transfer in non-regenerative relay networks,” *IEEE Trans. Veh. Technol.*, vol. 63, no. 5, pp. 2462–2467, Jun. 2014.
- [89] G. Zheng, Z. Ho, E. A. Jorswieck, and B. Ottersten, “Information and energy cooperation in cognitive radio networks,” *IEEE Trans. Signal Process.*, vol. 62, no. 9, pp. 2290 – 2303, May 2014.
- [90] X. Zhang, *Matrix Analysis and Applications*. Tsinghua, China: Tsinghua Univ. Press, 2004.
- [91] A. Charnes and W. W. Cooper, “Programming with linear fractional functions,” *Naval Res. Logist. Quart.*, vol. 9, no. 3-4, pp. 181-186, 1962.
- [92] M. Grant and S. Boyd. "Cvx: Matlab software for disciplined convex programming," [Online]. Available: <http://cvxr.com/cvx>
- [93] Y. Huang and D. P. Palomar, “Rank-constrained separable semidefinite

- programming with applications to optimal beamforming,” *IEEE Trans. Signal Process.*, vol. 58, no. 2, pp. 664-678, Feb. 2010.
- [94] M. Tao and R. Wang, “Robust relay beamforming for two-way relay networks,” *IEEE Communications Letters*, vol. 16, no. 7, pp. 1052-1055, July 2012.
- [95] H. S. Chen and W. Gao. "Mac and phy proposal for 802.11af," [Online]. Available:

<http://mentor.ieee.org/802.11/dcn/10/11-10-0258-00-00af-mac-and-phy-proposal-for-802-11af.pdf>
- [96] H. Ju and R. Zhang, “Optimal resource allocation in full-duplex wireless powered communication network,” *IEEE Trans. Commun.*, vol. 62, no. 10, pp. 3528 - 3540, Oct. 2014.
- [97] C. Zhong, H. A. Suraweera, G. Zheng, I. Krikidis, and Z. Zhang, “Wireless information and power transfer with full duplex relaying,” *IEEE Trans. Commun.*, vol. 62, no. 10, pp. 3447 - 3461, Oct. 2014.
- [98] Y. Zeng and R. Zhang, “Full-duplex wireless-powered relay with self-energy recycling,” *IEEE Wireless Commun. Letters*, vol. 4, no. 2, pp. 201-204, April

2015.

- [99] T. Marzetta, “Noncooperative cellular wireless with unlimited numbers of base station antennas,” *IEEE Trans. Wireless Commun.*, vol. 9, no. 11, pp. 3590–3600, Nov. 2010.
- [100] R. A. Horn and C. R. Johnson, *Matrix Analysis*. Cambridge University Press, 1985.
- [101] “Tgn channel models,” *IEEE 802.1103/940r4, Tech. Rep.*, May 2004.
- [102] H. G. Schantz, “Near field propagation law and a novel fundamental limit to antenna gain versus size,” *IEEE Antennas and Propag. Society Int. Symposium*, July 2005.
- [103] G. Zheng, S. H. Song, K. K. Wong, and B. Ottersten, “Cooperative cognitive networks: Optimal, distributed and low-complexity algorithms,” *IEEE Trans. Signal Process.*, vol. 61, no. 11, pp. 2778–2790, June 2013.
- [104] A. K. Sadek, K. J. R. Liu, and A. Ephremides, “Cognitive multiple access via cooperation: Protocol design and stability analysis,” *IEEE Trans. Inf. Theory*, vol. 53, no. 10, pp. 3677–3696, Oct. 2007.

- [105] O. Simeone, Y. Bar-Ness, and U. Spagnolini, "Stable throughput of cognitive radios with and without relaying capacity," *IEEE Trans. Commun.*, vol. 55, no. 12, pp. 2351-2360, Dec. 2007.
- [106] O. Simeone, I. Stanojev, S. Savazzi, Y. Bar-Ness, U. Spagnolini, and R. Pickholtz, "Spectrum leasing to cooperating secondary ad hoc networks," *IEEE J. Sel. Areas Commun.*, vol. 26, no. 1, pp. 203-213, Jan. 2008.
- [107] W. Su, J. Matyjas, and S. Batalama, "Active cooperation between primary users and cognitive radio users in cognitive ad-hoc networks," in *Proc. IEEE ICASSP*, Dallas, TX, Mar. 2010, pp. 3174-3177.
- [108] K. Hamdi, K. Zarifi, K. B. Letaief, and A. Ghayeb, "Beamforming in relay-assisted cognitive radio systems: A convex optimization approach," in *Proc. IEEE Int. Conf. Commun.*, Kyoto, June 2011, pp. 1-5.
- [109] S. H. Song and K. B. Letaief, "Prior zero-forcing for relaying primary signals in cognitive network," in *Proc. IEEE Global Commun. Conf.*, Houston, TX, USA, Dec. 2011, pp. 1-5.