

Immersion Scanning Thermal Microscopy - Probing Nanoscale Heat Transport in Liquid Environments

Oleg V. Kolosov and Peter D. Tovee

Physics Department, Lancaster University, Lancaster, LA1 4YB, UK
o.kolosov@lancaster.ac.uk; p.tovee@lancaster.ac.uk; www.nano-science.com

Abstract While Scanning Thermal Microscopy (SThM) using locally heated nanoscale probes is known for its ability to map heat transport and thermal properties of materials and devices with micro and nanoscale resolution. Such studies in the liquid environments were perceived to be impossible due to dominating heat dissipation from the heated probe into the surrounding liquid that would also deteriorate spatial resolution. Here we show that contrary to the common belief, the heat generated by the SThM nanoscale probe remains localised within the well-defined nanoscale volume, and that the amount of local heat transfer to the sample is comparable to the one of the standard ambient environment in organic and inorganic liquids. Moreover, the presence of liquid provides highly stable thermal contact between the probe tip and the sample eliminating one of the major drawbacks of the ambient or vacuum SThM's – variability of such contact. We show that such immersion SThM, or iSThM can effectively observe the semiconductor devices with the resolution of few tens of nanometres, providing new tool for exploring thermal effects of chemical reactions and biological processes with nanoscale resolution.

Keywords: Scanning Thermal Microscopy, SThM, nanoscale heat transport, immersion, heat transport in liquids, nanoscale.

1. Introduction

Nanoscale thermal properties are becoming of extreme importance in modern nanotechnology – they govern operation of processor chips and RF amplifiers that dissipate increasing power on the length scale of few tens of nanometers, performance of thermoelectric materials and sensitivity of nanoscale biosensors. In particular, nanoscale thermal transport in liquid environments is vital for understanding activity of heterogeneous catalysis during chemical reaction, functioning of power storage devices such as rechargeable batteries and supercapacitors, and is important for diverse biomedical studies.

While Scanning Thermal Microscopy (SThM) (Majumdar, 1999, Shi and Majumdar, 2002) that uses a microfabricated probe with nanoscale sized tip seem to be a perfect instrument for probing nanoscale thermal properties (Hinz et al., 2008, Pumarol et al., 2012), its operation in liquid environments until recently was considered impossible as the heat flow to the environment would be increased due to the high surface-to-volume area of the probe, and hence preclude its efficient operation in a liquid. Some results that show operation of the SThM in liquids demonstrated significantly reduced lateral resolution on the μm length scale (Aigouy et al., 2011).

Nevertheless, here we show that such SThM operation is possible and the new immersion SThM (iSThM) that can operate in the organic liquids (Tovee and Kolosov, 2013) should also be efficient for operation in the water based environments – a valuable feature essential for various real-life applications.

2. Exploring possibility of iSThM via FEA approach.

Our recent theoretical analysis of SThM (Tovee et al., 2012) based on the finite elements analysis (FEA) applied to liquid environments, showed that for a certain SThM probe design (KNT, UK) with the resistive heater located near the tip apex, the thermal signal is only moderately affected, by less than 50 % on immersion in a dodecane environment.

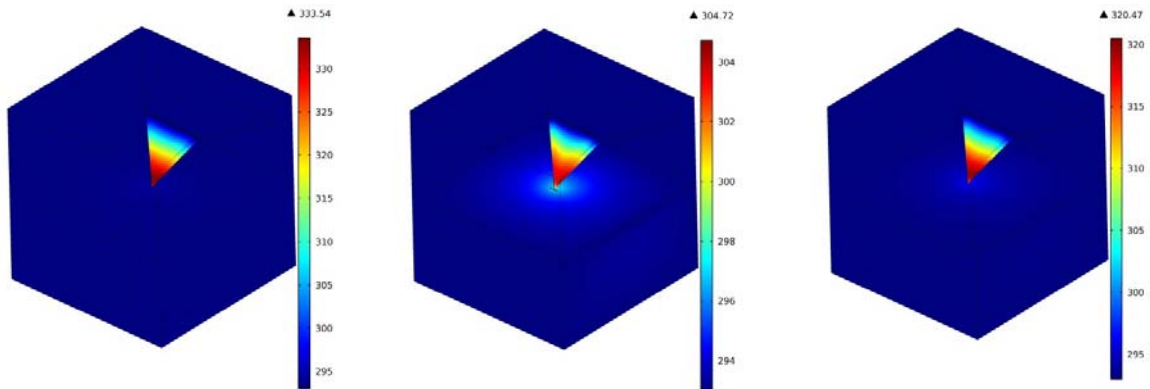

Fig. 1. Comparison of the tip and sample heating for in-air SThM (left panel) with the in-water (centre panel) iSThM and in-heptane (right panel) iSThM. Note the localised sample heating under the probe in water environment. Sample is SiO₂ glass.

In Fig. 1 we compare the results of the FEA simulation of the SThM probe in air for the sample of relatively low thermal conductivity (SiO₂) of few WK⁻¹m⁻¹ with the in-water and in-heptane iSThM. The temperature scale shows the highest excess temperature of the probe $T_p=333$ K (compared to the ambient temperature $T_0=293$ K) is in the air environment, and in heptane T_p reaches 320 K. Even in water $T_p=304$ K the response is more than 10 K above T_0 , that is sufficient for SThM measurements. Additionally, one can see in Fig. 1 that some de-localised heating of the sample under the probe tip is more notable in the water environment for the relatively low conductivity SiO₂ glass.

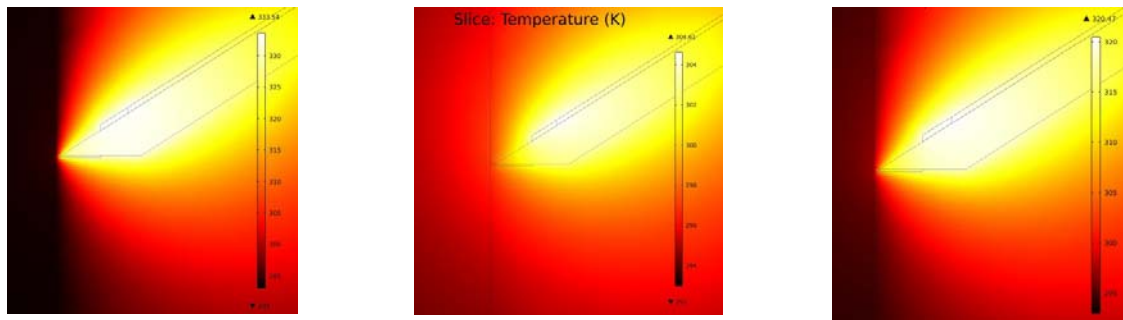

Fig. 2. 2D crosssection of the zoomed-in sample heating for in-air SThM (left panel) compared with the in-water iSThM (centre panel) and in-heptane iSThM (right panel). The SiO₂ sample heating under the probe in water environment matches the results for the 3D image in Fig. 1.

We further analyse this behaviour by zooming in onto the probe-sample contact in Fig. 2. The data show that the heating is more de-localised for in-water iSThM. This suggests that the water (that has thermal conductivity approximately 4 times higher than heptane) as well as other higher thermal conductivity liquid environments would be more beneficial for nanoscale heat transport studies of higher thermal conductivity materials, such as Si or metals. As such are the most materials used in the semiconductor industry, the in-water iSThM may open a new possibilities for those studies.

2. Experimental realisation of iSThM

Our experimental realisation of iSThM is based on a general purpose SPM (Bruker Multi-Mode, Nanoscope III) with SThM probes holder modified for using thermal probe in liquids as shown in Figure 3. A special cup with a glass window was used to contain the liquid and to create a flat refraction interface for SPM laser beam that monitors cantilever deflection.

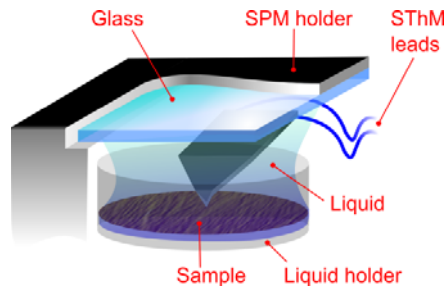

Fig. 3. Experiment setup of iSThM cell.

The SP thermal probe was calibrated on a variable temperature plate at temperatures ranging from room temperature to 60⁰ C by measuring probe electrical resistance as a function of the applied voltage and ambient temperature. The AC and DC voltage excitation for all measurements was provided by the precision function generator (Model 3390, Keithley Instruments). As the tip is brought in contact with the surface during SThM imaging, some heat starts to flow into the sample cooling the tip and, consequently, changing resistance of the sensor. Using a Maxwell bridge and combined AC-DC excitation (Tovee et al., 2012) schematically illustrated in Fig. 4 allowed to define power applied to the sensor and to measure the tip temperature via signal at the lock-in amplifier. As the tip is scanned across the sample, monitoring these values provides a thermal profile with the lower temperature of the probe corresponding to the higher local heat flux into the sample, therefore allowing direct evaluation of its local thermal conductivity.

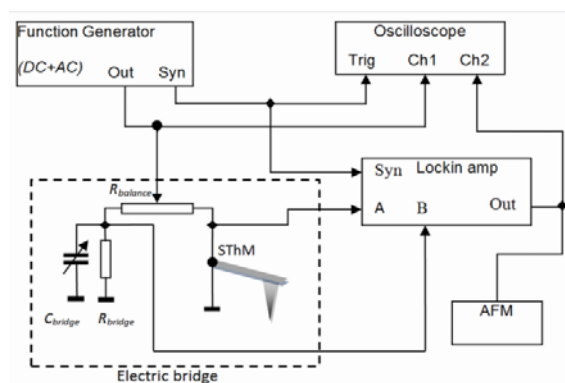

Fig. 4. Electronic setup for operations iSThM

Using such iSThM setup we reliably obtained spatially resolved 1D profiles for the probe across the the polymer – Al interface (Fig. 5). While the total signal was lower compared to in-air SThM with reduced signal-to-noise ratio by factor of 2, lateral resolution of the probe was not significantly reduced and was measured to be in the 50-100 nm range. Whereas using current KNT probe in water based environments requires modification of a conductive layer to avoid electrochemical corrosion of the probe,

the remarkable qualitative correlation of the experimental data with the FEA analysis in Fig. 5 indicated that it can be used for predicting lateral resolution of iSThM for various liquids and probed materials.

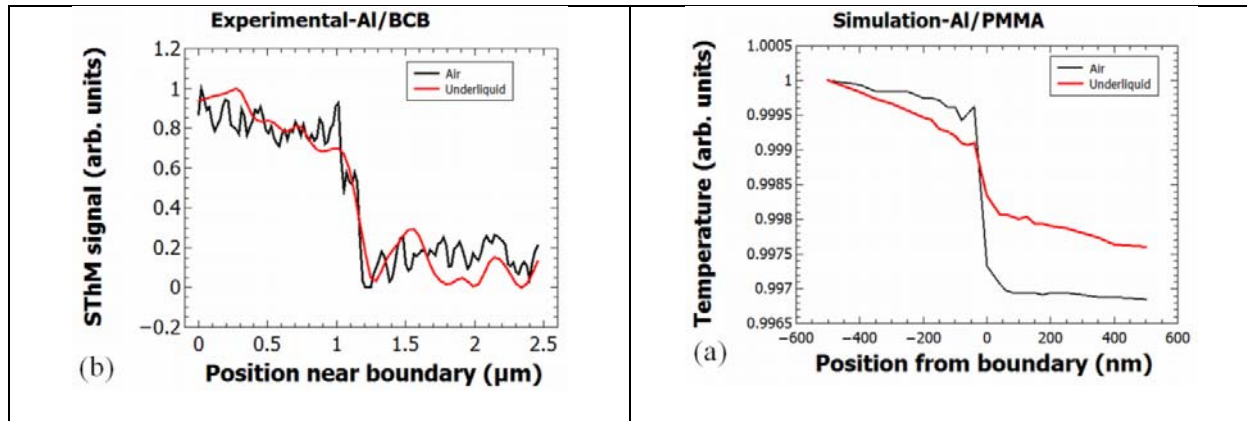

Fig. 5. (left panel) Experimentally measured spatially resolved response of the iSThM probe compared to SThM response of the same probe in the air environment produced by scanning across the polymer – Al interface. (Right panel) FEA simulation of the same response.

4. Conclusion

In conclusion, we show that iSThM can be used for the investigation of the nanoscale heat transport and thermal conductivity in variety of liquids, including highly important water based environments. While the absolute value of iSThM signal is reduced compared to SThM one, iSThM spatial resolution, surprisingly, remains unaffected. Additionally, the thermal contact between the tip apex and the studied sample beneficially improved eliminating detrimental effects of surface roughness. Finally, good correlation of the experimental data and FEA simulation allows to use such analysis for effective design of new probes and measurements of nanoscale heat transport in iSThM.

Acknowledgements

Authors acknowledge the support from the EU projects QUANTIHEAT and FUNPROB as well as EPSRC grant EP/K023373/1.

References

- Aigouy, L., Lalouat, L., Mortier, M., Low, P. & Bergaud, C. (2011). Note: A scanning thermal probe microscope that operates in liquids. *Review of Scientific Instruments*, 82.
- Hinz, M., Marti, O., Gotsmann, B., Lantz, M. A. & Durig, U. (2008). High resolution vacuum scanning thermal microscopy of HfO₂ and SiO₂. *Applied Physics Letters*, 92, 3.
- Majumdar, A. (1999). Scanning thermal microscopy. *Annual Review of Materials Science*, 29, 505-585.
- Pumarol, M. E., Rosamond, M. C., Tovee, P., Petty, M. C., Zeze, D. A., Falko, V. & Kolosov, O. V. (2012). Direct Nanoscale Imaging of Ballistic and Diffusive Thermal Transport in Graphene Nanostructures. *Nano Letters*, 12 (6), 2906–2911.
- Shi, L. & Majumdar, A. (2002). Thermal transport mechanisms at nanoscale point contacts. *Journal of Heat Transfer-Transactions of the Asme*, 124, 329-337.
- Tovee, P., D. & Kolosov, O., V. (2013). Mapping nanoscale thermal transfer in-liquid environment—immersion scanning thermal microscopy. *Nanotechnology*, 24, 465706.
- Tovee, P., Pumarol, M. E., Zeze, D. A., Kjoller, K. & Kolosov, O. (2012). Nanoscale spatial resolution probes for Scanning Thermal Microscopy of solid state materials. *J. Appl. Phys.*, 112, 114317.