

**Investigating Chinese Students' Academic  
Reading Practices in a UK University: A New  
Literacy Studies/Activity Theory Approach**

Xiao Cheng

**BA (Shanghai), MA (Lancaster)**

**Submitted for the degree of Ph.D.**

**July 2006**

**Department of Linguistics and English Language**

**Lancaster University**

ProQuest Number: 11003625

All rights reserved

INFORMATION TO ALL USERS

The quality of this reproduction is dependent upon the quality of the copy submitted.

In the unlikely event that the author did not send a complete manuscript and there are missing pages, these will be noted. Also, if material had to be removed, a note will indicate the deletion.



ProQuest 11003625

Published by ProQuest LLC (2018). Copyright of the Dissertation is held by the Author.

All rights reserved.

This work is protected against unauthorized copying under Title 17, United States Code  
Microform Edition © ProQuest LLC.

ProQuest LLC.  
789 East Eisenhower Parkway  
P.O. Box 1346  
Ann Arbor, MI 48106 – 1346

*To my parents,*

*Mimi,*

*and Yaoqiang*

---

# **Investigating Chinese Students' Academic Reading Practices in a UK University: A New Literacy Studies/Activity Theory Approach**

**Xiao Cheng**  
BA (Shanghai), MA (Lancaster)

Submitted for the degree of Ph.D.  
July 2006

## **Abstract**

The research study reported in this thesis explores Chinese postgraduate students' academic reading practices in Lancaster University (UK) from a combined New Literacy Studies (NLS) and Activity Theory (AT) perspective. It attempted to investigate the academic reading practices that the students in question undertook while writing their assignments, with a view to revealing some of the interacting historical, social, cultural, and institutional factors that were seen as influential in shaping the nature of their current reading practices. The data were gathered mainly through ethnographic interviewing, observations of lecture sessions, and document collection in the academic year 2004/05.

The findings indicate that the students' individual characteristics, their prior educational experiences under the Chinese education system, and the current contexts of their masters' programmes jointly affected their reading practices and experiences. In particular, the students' self-perception and long-established attitudes towards learning and reading remained fundamentally similar during their studies in the UK and played essential parts in shaping their reading practices. Also, in the context of their current studies, the clarity and explicitness of tutors' requirements, tutor-student communications, the availability of tutor support, the differences in the academic

---

conventions between China and the UK, and so on, were additional important influences in this matter. The thesis also discusses the pedagogical implications for EAP and subject-area teaching, with an attempt to indicate how more beneficial and rewarding academic reading experiences for Chinese students might be achieved in the UK higher education context. It likewise demonstrates and discusses the advantages of using a combined NLS and AT framework for throwing new light on academic reading in an L2 context.

**Key words: New Literacy Studies (NLS), Activity Theory (AT), activity system model, academic reading, Chinese postgraduate students, UK Higher Education.**

---

## Acknowledgement

First and foremost, I would like to express my deepest gratitude to my supervisor – Dr. Alan Waters, who has guided me through this prolonged and difficult journey, with his distinguished expertise, non-exhausting patience, thorough understanding, and generous encouragement. Those enlightening and inspiring supervision meetings, which were also very often comforting and amusing, will constitute part of my most cherished memory.

Sincere thanks also go to Prof. Charles Alderson, who directed me into the area of reading research at the beginning of my study; to Prof. Roz Ivanič and Dr. Uta Papen, who provided valuable feedback on my research in the upgrade panel and the annual review panel meetings; and to Dr. Dick Allwright, who offered useful suggestions for the orientation of the pilot study.

I am most grateful to all the Chinese postgraduate students who agreed to participate in my research and sacrificed so much of their precious time to make this research possible; and to all the members of staff at Lancaster University who accepted my interviews and generously provided me with useful information concerning the courses they taught and the feedback on the students' writings.

Sincere gratitude must be extended to Mrs. Marjorie Wood, whose very presence provided me with the strength and courage to face the difficult times, and who generously offered me her shoulders and tissues whenever I needed them.

I am also most grateful to my best friend in Lancaster – Yufang Qian, and her son Muyang, for treating me as part of their family and offering me the warmth and love of family life, which lightened up my life in the absence of my own family.

I would like to thank my colleagues and friends in the department – Saiqa Asif,

---

Yaling Chang, Dina Tsagari, Namwan Wijitsopon, May Wong, Liying Wu, and Dr. Xiao Zhonghua (and his family), for their company, comfort, and encouragement.

Finally, I would like to express my most sincere gratitude to my parents (Gaoxuan Cheng and Jian'e Pan), without whose selfless love and continuous support, financially, psychologically and physically, this research would have been impossible to take place. Special thanks to my daughter – Mimi, who was conceived, born and growing as this thesis was, and who tolerated life without Mom for two years, and to my husband – Yaoqiang Chen, whose love, support and sacrifice accompanied me all the way through. Also, I would like to thank my parents-, sister- and brother-in-law, my brother and sister-in-law, and my cousins – Xunyi Pan and Weiqin Li, for their enormous help in caring of my daughter in my absence.

---

## **Declaration**

This thesis is my own work and has not been previously submitted for the award of a higher degree elsewhere.

Xiao Cheng

July 2006



---

# Table of Contents

Abstract .....	i
Acknowledgement .....	iii
Declaration .....	v
Table of Contents .....	vi
Appendices .....	xi
List of Figures .....	xii
List of Tables .....	xiii
Glossary .....	xiv
Chapter One: Introduction .....	1
1.1 Introduction .....	1
1.2 Purpose .....	1
1.3 Focus and Orientation .....	3
1.4 The Structure of this Thesis .....	10
Chapter Two: Towards a Theoretical Framework .....	12
2.1 Introduction .....	12
2.2 Models of Literacy .....	12
2.2.1 The Autonomous Model of Literacy .....	13
2.2.2 The Ideological Model of Literacy .....	18
2.2.3 NLS in Academic Literacy .....	23
2.3 Working Concepts in the New Literacy Studies (NLS) Approach .....	26
2.3.1 Literacy Events .....	27
2.3.2 Literacy Practices .....	28
2.3.3 Context .....	30
2.3.3.1 Language in Context .....	31
2.3.3.2 Literacy in Context .....	34
2.3.4 Network .....	39
2.3.5 Ruling Passions—the Emotional Dimension in Literacy Practices .....	41
2.3.6 Community .....	42
2.3.7 Summary .....	43
2.4 Activity Theory (AT) Approach to the Study of Literacy Practices .....	44
2.4.1 Common Theoretical Root of NLS and AT .....	44
2.4.2 Activity Theory and Activity System Model .....	47
2.4.2.1 Action and Activity .....	47
2.4.2.2 Activity System (AS) Model .....	50
2.4.2.3 Advantages of the AS Model and its Suitability for My Study .....	54
2.4.3 Summary .....	57
2.5 Conclusion .....	58
Chapter Three Methodology .....	60
3.1 Introduction .....	60
3.2 Research Approach—Ontology and Epistemology .....	60
3.2.1 Ontological Position .....	60
3.2.2 Epistemological Position .....	63
3.3 Research Design .....	67
3.3.1 Pilot Study .....	68
3.3.2 Research Questions .....	71
3.3.3 The Subjects .....	73
3.3.4 Methods of Data Collection .....	77
3.3.4.1 Ethnographic Interviewing .....	79
3.3.4.2 Observation .....	80
3.3.4.3 Document Collection .....	82
3.3.5 Research Procedure .....	82
3.3.5.1 Preparation before the Main Study .....	82
3.3.5.2 Recruitment of the Subjects .....	83
3.3.5.3 Data Collection .....	85
3.3.5.4 Data Treatment and Analysis .....	86
3.4 Issues .....	88
3.5 Conclusion .....	90
Chapter Four: Stories of the Four Chinese Students and the Past Activity System .....	91

4.1 Introduction .....	91
4.2 A Historical Account of E1's Experiences of Learning and Reading in Two Languages .....	92
4.2.1 A Book Lover by Nature—Reading in Chinese .....	93
4.2.2 An Unsatisfied Learner of Chinese at School.....	95
4.2.3 A Top Student in a Foreign Languages Middle School .....	96
4.2.4 A 'Careful Investor'—Literacy Practices at University in China.....	98
4.2.5 Summary .....	101
4.3 A Historical Account of E2's Experiences of Learning and Reading in Two Languages .....	102
4.3.1 A Reluctant Reader.....	102
4.3.2 An Average Student Who Loved History .....	104
4.3.3 Learning of Two Languages.....	105
4.3.3.1 Learning Chinese .....	105
4.3.3.2 Learning English.....	106
4.3.4 Literacy Practices at University .....	107
4.3.5 Summary .....	110
4.4 A Historical Account of M1's Experiences of Learning and Reading in Two Languages .....	111
4.4.1 Learning and Reading in Chinese at School.....	111
4.4.2 Learning and Reading in English at School .....	113
4.4.3 Reading Practices at University .....	114
4.4.3.1 Reading in Chinese .....	114
4.4.3.2 Reading in English.....	115
4.4.4 Summary .....	117
4.5 A Historical Account of M2's Experiences of Learning and Reading in Two Languages .....	118
4.5.1 Learning and Reading in Chinese at School.....	119
4.5.2 Learning and Reading in English at School .....	120
4.5.3 Reading Practices at University .....	121
4.5.4 Summary of the Four Subjects—RQ 1.....	124
4.6 The Past AS .....	127
4.6.1 'Subject' .....	128
4.6.2 'Object' .....	130
4.6.2.1 Primary and Secondary Education.....	130
4.6.2.2 Tertiary Education.....	132
4.6.3 'Mediating Artefacts' .....	135
4.6.4 'Community', 'Division of Labour', and 'Rule' .....	136
4.6.5 Roles of the Components in the Subjects' Reading Practices .....	139
4.6.5.1 Family Factor—Pre-schooling Stage.....	139
4.6.5.2 The Role of the 'Object' .....	139
4.6.5.3 The Role of the 'Community'.....	140
4.6.5.4 The Role of the 'Rule' and 'Division of Labour'.....	141
4.7 Conclusion .....	141
Chapter Five: The Activity Systems of the Two Masters' Programmes .....	143
5.1 Introduction .....	143
5.2 Life in a Small Town in the North of England.....	144
5.3 Reading Practices in General.....	147
5.3.1 E1's Case.....	148
5.3.1.1 Three Stages of Reading Practices in Term One.....	148
5.3.1.2 Construction of 'Object' .....	152
5.3.2 E2's Case.....	155
5.3.2.1 Pre-sessional Course.....	155
5.3.2.2 Term Time Reading .....	156
5.3.3 M1 and M2's Cases.....	160
5.3.3.1 Pre-sessional Course.....	160
5.3.3.2 Term Time Reading .....	161
5.3.4 Summary .....	164
5.4 The Masters' Programmes as Activity Systems (AS) .....	166
5.4.1 'Subject' .....	167
5.4.2 'Object' .....	169
5.4.3 'Mediating Artefacts' .....	172
5.4.4 'Community' .....	177
5.4.5 'Rule' .....	178
5.4.6 'Division of Labour' .....	180
5.4.7 Summary .....	182
5.5 Inner Conflicts in the AS .....	183
5.5.1 'Subject'—'Object' .....	183
5.5.2 'Subject'—'Mediating Artefacts' .....	183

5.5.3 'Subject'—'Community' .....	186
5.5.4 'Subject'—'Division of Labour' and 'Rule' .....	192
5.5.5 'Community'—'Object' .....	192
5.5.6 'Community'—'Rule' .....	193
5.6 Conclusion .....	194
<b>Chapter Six: Doing the First Assignment - E1 and E2's Experiences</b> .....	<b>196</b>
6.1 Introduction .....	196
6.2 E1's First Assignment .....	197
6.2.1 The Process of Construction of 'Object'—Five Stages .....	198
6.2.1.1 Understanding the Writing Task and Identifying the Reading task .....	198
6.2.1.2 Finding a Way into the World of 'Research' .....	200
6.2.1.3 Choosing and Developing the Research Topic .....	202
6.2.1.4 Learning to Construct a Questionnaire .....	205
6.2.1.5 Integrating Reading into Writing .....	206
6.2.1.6 Summary .....	208
6.2.2 Tutor's Comments vs. E1's Reflection on Her Reading and Writing .....	210
6.3 E2's First Assignment .....	216
6.3.1 The Process of Construction of 'Object' .....	216
6.3.1.1 Choosing the Topic—a Choice out of Convenience .....	217
6.3.1.2 Identifying and Searching for the Literature .....	217
6.3.1.3 Reading .....	218
6.3.1.4 Integrating Reading into Writing .....	221
6.3.1.5 Summary .....	222
6.3.2 E2's Reflection vs. Tutor's Feedback .....	223
6.4 An Activity System View of E1 and E2's Cases .....	227
6.4.1 'Subject' .....	227
6.4.1.1 Personal Literacy and Education History .....	228
6.4.1.2 Emotional Aspect—Seeking a Sense of Security and Certainty .....	230
6.4.2 Relationship between the 'Subject' and 'Community' .....	232
6.4.2.1 Network of Support .....	232
6.4.2.2 Conflicts between the 'Subject' and 'Community' .....	233
6.5 Conclusion .....	235
<b>Chapter Seven: Doing the Second Assignment—E1 and E2's Experiences</b> .....	<b>238</b>
7.1 Introduction .....	238
7.2 The Process of Construction of 'Object' .....	239
7.2.1 Choosing the Topic .....	239
7.2.2 Understanding the Task and Identifying Readings .....	241
7.2.3 Searching for the Readings .....	243
7.2.4 Reading and Integrating Reading into Writing .....	245
7.2.4.1 E1's Case .....	245
7.2.4.2 E2's Case .....	248
7.2.5 Summary .....	250
7.3 A System View of the Academic Reading Practices for Writing .....	251
7.3.1 'Subject' .....	251
7.3.1.1 The Influence of Personal History .....	251
7.3.1.2 The Emotional Aspect of Reading for Writing .....	253
7.3.2 'Subject' vs. 'Community', 'Rule' and 'Division of Labour' .....	257
7.3.2.1 Network of Support .....	257
7.3.2.2 'Subject' and 'Community'—Non-cooperative Relation .....	258
7.3.2.3 'Subject' and 'Community'—Mismatch of Expectations .....	259
7.3.2.3.1 Regarding the Critical Review .....	259
7.3.2.3.2 Tutor's Feedback on the TLA Assignment vs. Students' Reflection .....	262
7.3.2.4 'Subject' vs. 'Rule' .....	265
7.3.2.5 'Subject' vs. 'Division of Labour' .....	266
7.4 Conclusion .....	268
<b>Chapter Eight: M1 and M2's Reading Practices in the MSc. in Management Activity System</b> .....	<b>272</b>
8.1 Introduction .....	272
8.2 Construction of 'Object' in Reading Activities .....	273
8.2.1 Individual Essay for the 'Learning to Manage' Module .....	273
8.2.1.1 Understanding the Task and Choosing the Topic .....	274
8.2.1.2 Identifying and Searching the Readings .....	276
8.2.1.3 Reading and Integrating Reading into Writing .....	278

8.2.1.3.1 M1's Case.....	278
8.2.1.3.2 M2's Case.....	281
8.2.2 Group Project Report for the 'Economics for Managers' Module .....	283
8.2.2.1 Understanding the Task and Choosing the Topic.....	283
8.2.2.2 Identifying and Searching the Readings .....	287
8.2.2.3 Reading and Integrating Reading into Writing .....	288
8.2.2.4 Summary.....	290
8.3 A System View of Reading Practices—Components of the Activity System and the Relationship between Them.....	292
8.3.1 'Subject' .....	292
8.3.1.1 Personal History and Personal Difference .....	292
8.3.1.2 Emotional Aspect of Reading for Writing .....	294
8.3.2 'Subject' vs. 'Community' .....	296
8.3.2.1 Supportive Relationship—the Network of Support.....	297
8.3.2.2 Conflicts and Contradictions between 'Subject' and 'Community'.....	298
8.3.2.2.1 Competition and Conflicts between the Students .....	298
8.3.2.2.2 Conflicts and Contradictions between Students and Tutors.....	300
8.3.3 'Subject' vs. 'Rule'.....	308
8.3.4 'Subject' vs. 'Division of Labour'.....	309
8.4 Conclusion .....	310
Chapter Nine: Conclusions.....	313
9.1 Introduction .....	313
9.2 Summary.....	313
9.3 Theoretical Insights .....	317
9.4 Pedagogical Implications.....	320
9.4.1 Implications for ELT in China.....	320
9.4.2 Implications for EAP Programmes.....	321
9.4.3 Implications for Subject Area Teaching in UK Higher Education .....	324
9.4.3.1 The Need for more Harmonious Tutor-Student Relationships.....	324
9.4.3.1.1 Understanding the Differences between the Two Education Systems .....	325
9.4.3.1.2 Understanding the Language Barrier.....	327
9.4.3.2 An Appropriate Level of Support.....	329
9.4.3.3 Programme Design .....	331
9.4.3.3.1 At the Intra-programme Level.....	332
9.4.3.3.2 At the Inter-programme Level .....	334
9.5 Limitations of the Study and Directions for Further Research .....	336
9.6 Final Remarks.....	337
Bibliography.....	339
Appendix 1: Questions for the first interviews with students.....	351
Appendix 2: Questions for the second interviews with students.....	354
Appendix 3: Questions for the third interviews with students .....	355
Appendix 4: Questions for the first interviews with subject tutors .....	356
Appendix 5: Questions for the second interviews with subject tutors.....	357
Appendix 6: Questions for the interviews with tutors of academic support course .....	358
Appendix 7: IER module outline .....	359
Appendix 8: IER module assessment details.....	362
Appendix 9: Feedback on E1's IER assignment .....	367
Appendix 10: Feedback on E2's IER assignment .....	368
Appendix 11: TLA module outline.....	369
Appendix 12: TLA module assessment details.....	372
Appendix 13: Feedback on E1's TLA assignments.....	375
Appendix 14: Feedback on E2's TLA assignments.....	377
Appendix 15: Marking criteria (Faculty of Arts and Social Sciences).....	378
Appendix 16: LM module outline .....	382
Appendix 17: LM module assessment details .....	385
Appendix 18: Feedback on M1's LM assignment.....	388
Appendix 19: Feedback on M2's LM assignment.....	389
Appendix 20: EM module outline .....	390
Appendix 21: EM module assessment details .....	393
Appendix 22: Feedback on M1's EM assignment.....	394
Appendix 23: Feedback on M2's EM assignment.....	395
Appendix 24: Marking criteria (Management School).....	396

---

Appendix 25: Questions for the first interviews with students (pilot study) .....	397
Appendix 26: Questions for the second interviews with students (pilot study) .....	399

---

## Appendices

Appendix 1: Questions for the first interviews with students.....	351
Appendix 2: Questions for the second interviews with students.....	354
Appendix 3: Questions for the third interviews with students.....	355
Appendix 4: Questions for the first interviews with subject tutors.....	356
Appendix 5: Questions for the second interviews with subject tutors.....	357
Appendix 6: Questions for the interviews with tutors of academic support course.....	358
Appendix 7: IER module outline.....	359
Appendix 8: IER module assessment details.....	362
Appendix 9: Feedback on E1's IER assignment.....	367
Appendix 10: Feedback on E2's IER assignment.....	368
Appendix 11: TLA module outline.....	369
Appendix 12: TLA module assessment details.....	372
Appendix 13: Feedback on E1's TLA assignments.....	375
Appendix 14: Feedback on E2's TLA assignments.....	377
Appendix 15: Marking criteria (Faculty of Arts and Social Sciences).....	378
Appendix 16: LM module outline.....	382
Appendix 17: LM module assessment details.....	385
Appendix 18: Feedback on M1's LM assignment.....	388
Appendix 19: Feedback on M2's LM assignment.....	389
Appendix 20: EM module outline.....	390
Appendix 21: EM module assessment details.....	393
Appendix 22: Feedback on M1's EM assignment.....	394
Appendix 23: Feedback on M2's EM assignment.....	395
Appendix 24: Marking criteria (Management School).....	396
Appendix 25: Questions for the first interviews with students (pilot study).....	397
Appendix 26: Questions for the second interviews with students (pilot study).....	399

---

## **List of Figures**

Figure 2.1 Language as discourse

Figure 2.2 Literacy in context

Figure 2.3 Social network

Figure 2.4 Mediated action

Figure 2.5 Activity system model

Figure 3.1 Ontology

Figure 4.1 Activity system of Chinese education system

Figure 5.1 Activity systems of UK and Chinese higher education

Figure 7.1 Process of constructing the 'object'

---

## **List of Tables**

Table 3.1 Pilot study subjects

Table 3.2 Main study—student interviewees

Table 3.3 Main study—tutor interviewees

Table 3.4 RQs and methods of data collection



---

## Glossary

AS	Activity system
AT	Activity theory
EM	'Economics for Managers' module
IER	'Introduction to Educational Research' module
L1	First language/mother tongue
L2	Second language/foreign language
LM	'Learning to Manage' module
NLS	New Literacy Studies
TLA	'Teaching, Learning and Assessment' module

Chapter One: Introduction.....	1
1.1 Introduction .....	1
1.2 Purpose .....	1
1.3 Focus and Orientation.....	3
1.4 The Structure of this Thesis .....	10

## **Chapter One: Introduction**

### **1.1 Introduction**

This chapter aims to explain the background of this research study, and the general rationale for the choice of the research focus and research approach. It will also present the overall structure of this thesis.

### **1.2 Purpose**

In recent years, there has been a rapid increase in the number of Chinese students studying in the UK higher education sector: the number has risen from 2,883 in 1997/98 to 32,000 in 2002/03, according to the UK Higher Education statistics agency (Universities-UK, 2005). Although a recent survey has suggested the number of applications has started to decrease, Chinese students still account for the largest number of overseas applicants (BBC-News, Feb 17, 2005). Moreover, it is not appropriate to consider Chinese students as a minority group, given the percentage of Chinese students in the whole student population: to take Lancaster University as an example, in the academic year 2004/2005 Chinese students accounted for 13% of all postgraduate students; in some programmes they even formed the majority (for example, 12 out of a class of 16 MA students in the Educational Research Department in the 2004-05 academic year were Chinese, and up to 50% of the whole class in the MSc. in Management programme came from China in 2004-05).

All such students are involved in a study process in which academic reading in English plays a crucial role. However, despite the large number of Chinese students, little research has so far been conducted concerning their experiences in this area. I

therefore felt it would be worthwhile researching what Chinese postgraduate students are actually experiencing regarding academic literacy practices of this kind in the UK university context. The need for such a study is recognised by at least some members of staff in UK higher education institutions. As one of the tutors that I interviewed for this research put it:

I need to know more about China, the system in China. I have so many (Chinese) students here and I know very little—where they are coming from, what they are doing, and why they are like that. (transst4/2:7, *my interpolation*)

Therefore, I felt that an investigation into Chinese students' academic reading practices may firstly help to improve our understanding of this particular area of their study experiences in UK universities - what do their studies involve in this respect, how well do they cope with them, what factors appear to affect their success, negatively and positively, and so on, thereby contributing to the development of knowledge of this kind with respect to Chinese students studying in the UK, but also, potentially, with respect to other groups of international students as well; secondly, I also felt that such a study might better inform members of staff in UK universities (and universities in other English speaking countries) of Chinese postgraduate students' actual academic reading experiences - e.g., in what ways they can be seen to cope well with their study requirements of this kind, but also where their problems tend to lie, and thus the kind of support and help the students might need most from the members of staff.

Apart from the potential usefulness of the research into Chinese students' academic reading practices and experiences mentioned above, my interest in this area also resulted from my experience as an English language teacher in a Chinese university (mainly teaching reading) before coming to the UK and as a postgraduate student at Lancaster University. As pursuing further studies abroad is one of the major occasions that my students will need to use English intensively

and authentically (another major occasion being working in multinational companies where English is the medium of communication), I felt this research might enable me to see how students manage their academic reading in the “real” situation, whether and how their English language education in China helps them with their real-life academic reading tasks, and how English teachers in Chinese universities could possibly prepare students for such experiences in optimum way during their undergraduate years.

Finally, the New Literacy Studies (NLS) framework that I encountered during my MA studies from a course run by Prof. David Barton seemed to yield illuminating insights into literacy that the traditional approaches to reading and writing could not achieve, yet it was seldom applied to studies of academic reading in English as L2. The Activity Theory (AT) framework that I also became acquainted with during the same period (from a thesis by Wu (2002) in this department) appeared to be an effective way of studying activities through exploring the relationships (i.e. conflicts and interactions) between different elements that are involved in an activity. Wu (2002) has demonstrated the analytical power of the AT in comparing and contrasting the old and new curriculum systems and in capturing the inner conflicts within each system in the process of a teacher-initiated curriculum innovation, which gave me some inspiration of how to apply the activity system model in the analysis of students’ academic reading activities. By combining these two frameworks in the study of L2 academic reading, I felt it was worth trying to see whether they might provide a new and interesting way of throwing light on the area of L2 academic reading.

### **1.3 Focus and Orientation**

As already indicated, the main focus of this study is on the reading side of the

academic literacy practices in question. Academic reading was chosen as the focus rather than academic writing because there are far fewer research studies related to academic reading than academic writing, as can be illustrated by the following three groups of statistics: I searched the phrases ‘academic reading’ and ‘academic writing’ in turn in three websites (i.e. Science Direct, Academic Search Premier, and Google Scholar), and retrieved 12 results for ‘academic reading’ and 107 results for ‘academic writing’ in Science Direct, 226 results for the former and 2689 results for the latter in Academic Search Premier, and 707 results for the former and 7210 results for the latter in Google Scholar. Although not every result retrieved is necessarily concerning academic reading or writing in its own right, the results nevertheless indicate that academic reading has been much less widely researched than academic writing. Despite the relative neglect of studies of academic reading, and although academic writing is undeniably important, since it is the primary product by which most students are assessed in higher education, academic reading is, of course, also of vital importance in students’ studies, as it provides materials and inspires ideas for written assignments (Leki, 2003; Peelo, 1994). It is thus the basis on which potential success in academic writing rests. Success in academic writing cannot be achieved without the student possessing an effective level of competence in coping with the requirements of the reading side of academic literacy practices, in other words. In a sense, students’ academic reading practices are inevitably inter-connected with their academic writing practices, and hence constitute an important and indispensable part of their academic studies in the academic discourse community (which will be shown in Chapters 6-8).

The approach adopted in this study, for reasons that will be explained in detail in the ensuing chapter, is to view the academic reading process as far as possible “in the round”. In other words, it has been seen as important to try to take into account recent

perspectives on literacy which look less at reading simply from a psycholinguistic perspective but which instead attempt to understand it in terms of what the learner and the learning context contribute to the experience. For this reason, the theoretical frameworks provided by the New Literacy Studies (NLS), on the one hand, and Activity Theory (AT) on the other, have been used as the main heuristics underpinning the research (see Chapter 2 in particular).

As far as existing research into reading goes, according to Mann “most studies (on L1 academic reading-*my interpolation*) have focused on student *learning* through text and have investigated relationships between approach, conception, outcomes, task definitions and context” (Mann, 2000:298, emphasis in the original), whereas very few studies have focused on the personal meanings and experiences involved in reading. In other words, reading is studied mostly at the micro level by looking at, for instance, the relationship between reading skills and strategies applied and the results in reading tasks or tests, the relationship between reading instruction and the performance in reading tests, the relationship between vocabulary knowledge and reading comprehension, and so on. Little is known about what reading means to a person’s life and learning; what significance is assigned to reading by individuals; how individuals experience the reading process; what factors have effect on individuals’ reading process apart from the immediate context of reading tasks; and so on.

Luke and Baker (1991), in an introduction to a collection of papers on ‘critical reading pedagogy’ at the basic education level (Baker & Luke, 1991), also pointed out the dominance of “the conceptualization of reading as an essentially internal, individual, cognitive process” (Luke & Baker, 1991: xi) in reading research and pedagogy. The contributors in Baker and Luke (1991) argue for the necessity of taking a critical social perspective on reading research and teaching: drawing “attention to

the origins, embeddedness, and place of (whatever counts as) ‘reading’ in economic, ideological, social and instructional formations” (Luke & Baker, 1991: xiii), “detailing how what now counts as reading in school has been historically, ideologically and culturally shaped, ..., and ... offering alternative perspectives on how reading can be conceptualized and on how the study of the practice of reading instruction in schools can proceed usefully” (ibid: xv). Although this collection of papers focuses on the basic education context, their conceptualization of reading is relevant in principle to the current study of academic literacy in higher education as well.

Examination of the research studies conducted in the area of second language (L2) reading seems to reflect a similar lack of research into reading experiences as indicated in Mann (2000) about the reading research in L1. For example, studies reported in the journal of ‘Reading in a Foreign Language’ (from 1983 to 2005) are mostly about the teaching of EF/SL reading in classroom settings, design of reading courses and reading materials, development of vocabulary, strategies instruction, reading comprehension, testing of reading, text analysis, etc. Also, Brantmeier, in order to provide L2 researchers with a convenient way of searching the latest relevant literature, summarizes publications on L2 reading during 2004 and 2005 in venues other than the journal of ‘Reading in a Foreign Language’, which again shows that investigations of reading comprehension, strategy instruction, vocabulary development, and the cognitive perspective of reading research still dominate the area of L2 reading research (Brantmeier, 2005). From Bernhardt’s two syntheses of L2 reading research in the 20<sup>th</sup> century, we may get a good idea of the trends in this area over three decades. In order to build an L2 reading model, Bernhardt examines the L2 reading research on adult readers (who are literate in L1) during the 1970s and 1980s in three areas: linguistic knowledge (e.g. word recognition, phonological aspects, lexical knowledge,

morphosyntactic knowledge, (Bernhardt, 1991:33)); literacy knowledge (i.e. “the operational knowledge that refers to knowing how to approach text, why one approaches it, and what to do with it when a text is approached”, *ibid*:35); world knowledge (i.e. cultural and topic knowledge, *ibid*:37). The studies in the first area mainly concern the relationship between the processing speed of word recognition and the L2 proficiency, vocabulary development and its influence on L2 reading, syntactic knowledge and reading comprehension; studies in the second area are mainly about strategy development and comprehension; the third area mainly deals with the relationship between reading comprehension and cultural or particular topic background knowledge. Her later work for the same purpose (Bernhardt, 2000) further points out that ‘metacognition’ and ‘affect’ in L2 reading were two areas rarely researched before the 1990’s. After reviewing the research studies in L2 reading during the last decade of the 20<sup>th</sup> century, she finds that the following areas “remained consistent instances of research interest”: affective factors, text structure, syntactic features, and word knowledge and instruction (Bernhardt, 2000: 798). As Bernhardt (1991) has commented:

It is quite possible that many of the findings in second language reading research are in actuality artefacts of the manner in which the measurement was taken. The majority of second language (reading) studies have used cloze (a syntactic/productive measure of clausal knowledge) or oral reading (a productive/performance measure that impedes comprehension) or multiple choice testing (a measure that interferes with the development of individual readers’ discourse models). . . . (M)any of the generalizations about L2 reading might be valid. We cannot determine their validity, however, until we allow all the variables entailed in reading—linguistic, literacy, and knowledge, to function simultaneously during real reading tasks with authentic texts. As long as we continue to manipulate both readers and texts, we will obscure the process we are attempting to investigate (Bernhardt, 1991:39).

Here, then, are the possible disadvantages of “mainstream” reading research, i.e. many of the reading tasks that were given to the readers for measurement of their reading comprehension may not be found in authentic situations; many of the texts used in the measurement may not be read in real-life situations; in many studies, one or more variables in reading (such as the level of difficulty of the texts, the readers’ language



proficiency, the topics of the texts in relation to the readers' background knowledge, etc.) were controlled, which is not likely to be the case in authentic reading situations, such as reading for the purpose of academic studies.

In investigating academic reading practices, thus, I thought it important to take into account recent conceptualisations of literacy practices in general and of academic literacy in particular, ones which might provide as complete a picture as possible of the student and the study context, and in this way avoid some of the limitations of the research tradition just outlined. Thus, Mann following Säljö's argument that "human action does not take place in a social vacuum" (Säljö, 1984:71), suggests that "(r)eading in the academic context cannot...be viewed as a purely neutral cognitive process undertaken in a social vacuum", which led her to investigate instead the students' experience of academic reading in order to "understand the meaning that reading in an academic context has for the individual student" (Mann, 2000:279). Mann studied four undergraduate students' (English as L1) academic reading experiences, by asking them to keep a reading diary over a week, to carry out a reading task, and to talk with the researcher about the diary, the way they approached the reading passage and the experience of reading it in a series of interviews. Her study reveals that reading needs to be viewed as "a meaningful activity which has significance for students in different ways" (ibid: 314). She concludes that "in order to **understand** the richness and complexity of reading, we need to view it as an activity that has both personal significance and socio-political significance. ... It is through trying to come closer to these biographical and socio-political realities for any one student that we can understand how it is that reading means (and) what it does for that person" (ibid:315-316, emphasis in the original). Her study has illustrated the importance and possibility of viewing academic reading from a different angle other than the more

dominant cognitive perspective of reading research.

Mann's view of reading echoes some of the principal propositions underpinning the theoretical model of literacy associated with the New Literacy Studies (NLS), which emphasize that reading and writing are always related to the social, cultural, historical practices of which they are a part, and thus can only be truly understood when studied within the specific contexts in which they take place (e.g. Barton, 1994:35). However, there are very few studies of reading which explicitly follow the NLS tradition, including Mann, one exception being Ridgway (2003). Ridgway, by adopting a NLS perspective, examines attitudes towards literacy in different countries and societies throughout history, and their valued or dominant styles in literacy practices, and concludes that values of literacy change over time, and vary from society to society and from culture to culture, which results in different attitudes and styles of reading among different societies and cultures (Ridgway 2003).

Moreover, research studies on academic *writing* using NLS as a theoretical framework have shown evidence of many new insights into academic *writing*, especially in relation to the study of writing by those who are new to western academic discourses, such as overseas students, mature students, etc. (Ivanič, 1997; C. Jones, Turner, & Street, 1999; Lea & Stierer, 2000; Lillis, 2001). Therefore, it seems both worthwhile and promising to focus the current study on academic *reading* within a similar theoretical framework, i.e., an NLS, social practice-oriented one. The academic reading practices and the contextual issues surrounding the academic reading will be in the centre of this research.

I also mentioned earlier that I felt it would be useful to use Activity Theory (AT) in this connection. The idea of bringing AT into the study of academic reading was to take advantage of the activity system model as a tool for theorising the contexts within

which the literacy practices were situated in the study the thesis is concerned with. Also, as will be explained in 2.4.1 below, the social orientation towards learning and knowledge shared by both NLS and AT makes it possible to profitably combine these two schools of thoughts together. In short, thus, it has been regarded as empirically necessary and rewarding, as well as theoretically feasible, to carry out a study on L2 academic reading practices from a combined NLS and AT approach in order to add to our understanding of the area of research in question and of the possible ways to apply the theoretical framework in focus.

#### **1.4 The Structure of this Thesis**

This chapter has attempted to introduce the research the rest of this thesis is concerned with, in terms of the rationale for the choice of the research focus, (i.e. academic reading experiences and practices of Chinese postgraduate students in a UK university) and the choice of the theoretical framework, (i.e. a combined NLS and AT approach). The overall purposes of the research have also been briefly introduced, and will be further developed in Chapter 3. In what follows, Chapter 2 establishes the theoretical framework that has guided the design and direction of the research. Chapter 3 justifies the choice of research methodology and methods of data collection, and documents the procedure that was used for conducting the research, the data treatment and data analysis. Chapters 4 and 5 clarify the contexts for the analysis of the data by retelling the four subjects' past experiences of literacy learning and practices in both their mother tongue and English, and their current literacy experiences and practices in general, and by constructing the activity system that the subjects used to belong to (Chapter 4), and the current activity systems of the two masters' programmes in which they were studying at the time of the data collection (Chapter 5). Chapters 6 and 7 focus on the two subjects from the MA. in Education programme, examining their academic

reading experiences and practices for the purpose of writing assignments through constructing the 'object' of their reading activities during the course of writing their assignments, and, by scrutinising the relationships between each pair of the components in the activity system, the factors contributing to their experiences and practices. Chapter 8 deals with the same type of analysis as the two previous chapters do, with the focus on the two subjects from MSc. in Management programme. Finally, Chapter 9 pulls together the arguments made throughout the thesis and draws out the wider implications of the current study for the teaching and researching of L2 academic reading.

Chapter Two: Towards a Theoretical Framework .....	12
2.1 Introduction .....	12
2.2 Models of Literacy.....	12
2.2.1 The Autonomous Model of Literacy .....	13
2.2.2 The Ideological Model of Literacy.....	18
2.2.3 NLS in Academic Literacy.....	23
2.3 Working Concepts in the New Literacy Studies (NLS) Approach.....	26
2.3.1 Literacy Events.....	27
2.3.2 Literacy Practices .....	28
2.3.3 Context.....	30
2.3.3.1 Language in Context.....	31
2.3.3.2 Literacy in Context .....	34
2.3.4 Network.....	39
2.3.5 Ruling Passions—the Emotional Dimension in Literacy Practices.....	41
2.3.6 Community.....	42
2.3.7 Summary .....	43
2.4 Activity Theory (AT) Approach to the Study of Literacy Practices .....	44
2.4.1 Common Theoretical Root of NLS and AT .....	44
2.4.2 Activity Theory and Activity System Model.....	47
2.4.2.1 Action and Activity .....	47
2.4.2.2 Activity System (AS) Model .....	50
2.4.2.3 Advantages of the AS Model and its Suitability for My Study.....	54
2.4.3 Summary .....	57
2.5 Conclusion.....	58

## Chapter Two: Towards a Theoretical Framework

### 2.1 Introduction

In this chapter, my main objective is to establish a working theoretical framework for the analysis of data through a review of the existing literature. I will present different schools of thoughts concerning literacy and different traditions of research into both reading and writing, with a view to building a case for following the school of New Literacy Studies (NLS). It will also be argued that Activity Theory (AT) should be adopted in this study as a way of theorizing the contexts in which the academic reading practices are situated. Thus, a review of the history and development of AT and the strengths of it as an analytical tool for the purposes of the research in question will also be presented in this chapter.

### 2.2 Models of Literacy

To turn first, thus, to models of literacy. Street (1984) uses the term ‘literacy’ to mean “the social practices and conceptions of reading and writing”, and argues that

there are two different approaches to the analysis of literacy, which he characterises as the ‘autonomous’ model and ‘ideological’ models (p.1).

### **2.2.1 The Autonomous Model of Literacy**

According to Street (1984, 1993a, 1993b) the ‘autonomous’ model of literacy refers to the way literacy is conceptualised by scholars such as Goody (1968, 1977), Goody and Watt (1988), Greenfield (1972), Hildyard and Olson (1978), and Ong (1982). Goody and Watt associate literacy and literate societies with “civilization”, rational and “logico-empirical” modes of thought, and social, economic, technological and political advance (Goody & Watt, 1988:14). By examining the way Greek philosophers such as Socrates, Plato, and Aristotle developed and wrote their works, they argue that the methods of western thought—such as logic, rationality, objectivity, abstraction—are intrinsically connected with writing (Goody & Watt, 1988:17). They believe in the existence of radical differences between literate and non-literate societies because “writing establishes a ... relationship between the word and its referent ... that is more general and more abstract, and less closely connected with the peculiarities of person, place and time” than is the language of oral communication (ibid:13); and believe that “the written word suggests an ideal of definable truths which have an inherent autonomy and permanence. ... (O)nce given the physical reality of writing, they (verbal words) take on a life of their own” whereas spoken words cannot be divorced from the rest of the sentence and the social contexts (ibid). They also suggest that acquisition of literacy improves cognitive and intellectual abilities, such as logical, abstract, and critical thinking. Ong (1988), like Goody and Watt (1988), holds that there are certain qualities pertinent to literacy and literate societies and orality and oral/non-literate cultures because of the intrinsic differences between writing and speaking. He depicts orally-based thought and expression as “aggregative, redundant, embedded in the

human lifeworld, situational, agonistic, and empathetic”, whereas literate thought as “analytic, abstract, neutral, and objective”(Ong, 1988). Olson (1988) claims that the transition from utterance to text<sup>1</sup> is an evolution both culturally and developmentally—the creation of “explicit, autonomous statements ... dependent upon an explicit writing system, the alphabet, and an explicit form of argument, the essay” brought about an altered conception of language and of rational man, which gave shape to many predominant features of Western culture (Olson, 1988:176). He further argues that writing (in order to make texts as autonomous representations of meaning) is a powerful intellectual tool to generate original theoretical knowledge.

What is in common for the scholars reviewed in the preceding paragraph is that they all see literacy (reading and writing) as “independent from social context, an autonomous variable whose consequences for society and cognition can be derived from its intrinsic character” (Street 1993a:5), possessing fundamentally different characteristics from orality (speaking and listening), and representing objective, neutral, logical, and permanent meanings that can be distanced from social and situational context. Although such scholars do not use the phrase “autonomous model of literacy” themselves, Street argues that the term ‘autonomous’ “draws attention to the underlying coherence and relationship of ideas which, on the surface, might appear unconnected and haphazard. ... the use of the concept helps us to see what is entailed by adopting particular positions, to fill in gaps left by untheorised statements about literacy, and to adopt a broader perspective than is apparent in any one writer on literacy” (Street 1984:3).

Hill and Parry (1990a) extend the discussion of the autonomous model of literacy in their consideration of reading tests, showing the dominance of this model in formal

---

<sup>1</sup> Utterance refers to “informal, oral-language statements”; text refers to “explicit, written prose statements” (Olson 1988:175-6).

education, and in the teaching and testing of reading in particular. Their discussion reveals that texts in such contexts are typically treated as autonomous. As they point out, Olson (1988) argues that “the transition from utterance to text ... can be described as one of increasing explicitness, with language increasingly able to stand as an unambiguous and autonomous representation of meaning” (p.176); and that the ideal text for schooling should “depend on no cues other than linguistic cues; it represents no intentions other than those represented in the text; it is addressed to no one in particular; its author is essentially anonymous; and its meaning is precisely that represented by the sentence meaning” (ibid:187). Hill and Parry notice that related to the concept of autonomy of text is the concept of the autonomy of skill—reading is viewed as a technical skill rather than a social skill, and once acquired, “it should not, in principle, be affected by the social identity of the reader, the origin of the text, or the purposes for which the text is being read”; or in other words, literacy is seen to be “socially neutral” (Hill and Parry 1990a:18). After examining reading tests in both the “British” tradition (i.e. open-ended questions) and the “American” tradition (i.e. multiple choice questions), Hill and Parry conclude that the tests share a common basic assumption—the autonomous model of literacy, i.e. autonomous texts are used to assess autonomous skill:

... test makers deliberately use a wide range of passages that candidates are unlikely to know much about, and they try to construct tasks that cannot be answered without reference to the text, even by someone well informed about its content. Indeed, the use of specialised knowledge can be a disadvantage, for it often leads to the choice of a distracter in a multiple-choice task or the inclusion of too much information in an open-ended one. ... The skill that they test, and thereby propagate, is a circumscribed kind of reading: it consists solely of perceiving ‘the very words’ of the text and drawing logical inferences from the propositions that they convey. ... other qualities, such as individuals’ factual knowledge, their ability to use it in obtaining new information from text, or their capacity for remembering and using such information for purposes other than immediate interpretation are all considered irrelevant. (1990a:19).

Hill and Parry (1990) also point out that the assumptions of the autonomous model of literacy have spread far wider than the area of testing of reading if we consider how the testing scores are used—students may be placed into different levels of reading



classes<sup>2</sup>, or subjects may be labelled as ‘good’ or ‘poor’ readers in research studies according to the test scores. Review of the literature also shows that studies of good/skilled/proficient readers and poor/unskilled/non-proficient readers abound in the area of both L1 and L2 reading research (e.g. Afflerbach & Johnston, 1986; Ahmad & Asraf, 2004; Anderson, 1991; Block, 1986; Brown, Armbruster, & Baker, 1983; Carrell, 1989; Chiappe, Chiappe, & Gottardo, 2004; Davey, 1987; Garner & Krauss, 1982; Guillund, 1996; Hosenfeld, 1977; Knight, Padron, & Waxman, 1985; Lau & Chan, 2003; Penney, Leung, Chan, Meng, & McBride-Chang, 2005; Wasson, Beare, & Wasson, 1990 amongst others), and reading tests are most commonly used to discriminate good from poor readers. The study of reading comprehension is another major topic in the area of reading research—there are studies of the relationship between comprehension and background knowledge (Alderson & Urquhart, 1988; Bernhardt, 1991, , 1991a; Brantmeier, 2005b; Carrell, 1984, , 1987; Chen & Donin, 1997; Hammadou, 2000; Hudson, 1988; Pulido, 2004; Ridgway, 1997), comprehension and reading strategies (Ahmad & Asraf, 2004; Carrell, Carson, & Zhe, 1993), comprehension and vocabulary knowledge or vocabulary development (Fukkink, Hulstijn, & Simis, 2005; Lubliner & Smetana, 2005; Nassaji, 2004), comprehension and text structure (Chambliss, 1995; Horiba, 2000; Martinez, 2002; Toledo, 2005; Wenger, 1993), and so on, in which the measurement of comprehension is an indispensable element which is usually achieved through reading tests with various task types (e.g. cloze, blank filling, multiple choice questions, true/false questions, recall, etc.). Another popular area of research, which also indicates the widespread influence of the autonomous model of literacy, is reading strategies/skills and instruction of such strategies/skills (Alfassi, 2004; Carrell & Carson, 1997; Dymock, 2005; Mutawa &

---

<sup>2</sup> Language placement tests are widely used at universities in many countries to allocate students to different levels of language courses. A reading component is usually an indispensable part of such tests.

Islam, 1994; Singhal, 2001; Stoller, 1994; Wood & Endres, 2004), since such studies assume that reading involves a set of strategies/skills that can be trained in educational settings and transferred to other situations once acquired. Studies on strategy instruction normally involve the evaluation of the effect of instruction, which is again usually achieved through comprehension tests of the kind mentioned above.

In short, the preceding discussion shows a long-standing tradition of reading research and instruction, which is underpinned by the autonomous model of literacy—viewing reading as psychological and cognitive processes and attributes within individual readers' minds and independent from the contexts of use.

However, the nature of academic reading extends beyond what can be accounted for by the autonomous model of literacy, as Säljö observes:

...the ability to read cannot be adequately considered as a mere technical skill denoting the ability to decipher strings of letters on a page. A core feature of much of the reading that is carried out in academic contexts is that individuals are required to see something in the outside world — be it the structure of physical objects, a historical development resulting in major social changes, or evolution — in a perspective which is not a familiar part of everyday thinking. ... This excursion into the fascinating topic of how people make sense of what they read is therefore to be conceived not merely as an inquiry into human capacity for learning in a narrow sense, but also into fundamental processes of knowledge-generation and mediation in a complex and dynamic cultural and scientific milieu where a multitude of — sometimes competing — conceptions of reality (Marton 1981) can be found (Säljö, 1984:71-72).

In the source from which the above quotation is taken, Säljö (1984) argues that reading in academic contexts is different from reading in everyday life (e.g. reading novels, newspapers) because students are required to view things from certain perspectives which are not familiar to them in everyday thinking, and students are often required to read something of others' choices and within certain time constraints (also see Peelo 1994, Mann 2000). Therefore, reading in different contexts “must not be assumed ... (as) one and the same cognitive activity” (Säljö 1984:72) as the autonomous model of literacy does. While these authors (Säljö 1984, Peelo 1994, Mann 2000) are all talking about native English speakers, the discussion of Chinese students' academic reading must also add to the picture cultural, educational and linguistic dimensions, as the

students are from a different culture and educational tradition and are now situated in a western academic context (see Cortazzi & Jin, 1996; Liu, 2005; Sowden, 2005; Watkins & Biggs, 1996 for discussion of cultural issues) and using a different language. As the quotation from Säljö (1984) above indicates, the notion of academic reading is unlikely to be “a familiar part of everyday thinking” even for students from the same educational tradition. This is, therefore, likely to be even more so for students from a different non-western educational tradition. For this reason, the autonomous model of literacy is unlikely to be helpful in understanding Chinese students’ academic reading.

In the foregoing section, I have showed the widespread influence of the autonomous model of literacy in the area of reading research and the inappropriateness of such a theory for my study of Chinese students’ L2 academic reading in a western university. To try to find a more suitable theory for my discussion of academic reading, I therefore now turn to the ideological model of literacy undergirding the New Literacy Studies (NLS).

### **2.2.2 The Ideological Model of Literacy**

In contrast to the picture underpinning the autonomous model of literacy, an alternative argument states that literacy practices are “always embedded in social and cultural contexts and moreover they are not simply neutral artefacts but are always contested and ideological” (Street 1993b:82). The discussion in 2.2.1 above indicates that the way literacy has been conceptualized in the autonomous model of literacy is largely based on the “essay-text” form of literacy (dominant in western academic circles to which scholars who support this view belong), which can be seen as socially constructed within western social traditions, and hence ideological in nature. Thus, scholars such as Goody, Olson, and Ong, emphasize the superiority of western alphabetic writing system to other writing systems, consider literacy with writing

systems other than alphabetic system as ‘restricted’ in terms of the scope of the literate population of the whole society, and view the western form of literacy as capable of fostering higher cognitive and intellectual abilities, all of which seem to confirm very well the ideology (of western traditions) and embeddedness (in western societies and cultures) of their own view of literacy (see in particular Goody 1968, 1977, Goody and Watt 1988, Olson 1988, Ong 1988). In reality, however, such claims are untenable, as the studies I will review next demonstrate.

Gough shows that non-alphabetic writing systems can also yield widespread literacy and sophisticated technology and civilization, as in India and China (Gough, 1988). Scribner and Cole point out that “it is a hazardous enterprise to attempt to establish causal relationships among selected aspects of social and individual function without taking into account the totality of social practice of which they are a part” (Scribner & Cole, 1988:57). They suggest a comparative approach—studying “seemingly ‘same’ practices in different societal contexts”—to investigate the intellectual impact of reading and writing practices. Thus, they combined anthropological field work and experimental psychological methods in a study of literacy practices of Vai people in a West African traditional society, where there are three scripts co-existing: English, Vai, and Arabic. English is taught at government-run schools and is used as the official script in political and economic institutions nationwide; Arabic is taught in Qur’anic schools<sup>3</sup> and is used in religious practices; Vai script is usually learned within a two-week to two-month period with the help of a friend or relative and serves the purpose of personal communication and community affairs in the villages<sup>4</sup>. The study indicated that schooled literacy does not lead to higher

---

<sup>3</sup> Learning usually only involves rote memorization of passages from Qur’an or frequently used prayers, without actual understanding of the language.

<sup>4</sup> Such as personal correspondence, record-keeping of public affairs.

cognitive or intellectual abilities and performance in a general sense, as the English literates educated in western-type schools did not perform better than other groups if they were not involved in schooled literacy practices after they left school; that certain activities involved in reading and writing may promote specific cognitive skills, or in other words, certain literacy practices are associated with certain skills and may promote those skills; and that it is uncertain whether literacy is a necessary or sufficient condition for any of the skills that were assessed, since not all non-literates were found to perform at a lower level than all literates in all tasks (Scribner & Cole, 1981, , 1988). This research shows that literacy does not have the general or global consequences on cognition claimed by some scholars. Instead, the effects of literacy are closely related to the practice of that literacy as part of people's social practices as a whole.

In his ethnographic study in an Iranian village in the 1970s, Street (1984, 1995) identified two types of literacies: the 'maktab' or Qur'anic school literacy, where students learn the Qur'an; and the 'modern' literacy taught in the state education system. Certain literacy conventions (such as 'the ordering of words on a page; the indicating of meaning by precise placing of words; the indication of the beginning and ending of words by different forms of a letter', 1995:41) learned in the 'maktab' are more or less 'hidden' compared with the skills taught in state schools, and 'maktab' students may be considered as 'illiterate' according to the formal school tests (1984:154). Yet the 'maktab' literacy learned from the 'maktab' enabled those who learned in this way to make their way through the Qur'an and other texts, and apply the information to their daily life—seeking the relevance between religious texts and their current situation, discussing and arguing with others about certain issues of their interest and so on.

Street also argues that the 'maktab' literacy facilitated the emergence of the 'commercial' literacy involved in fruit selling in mountain villages. The major form of

the ‘commercial’ literacy was a book of transaction records with neatly lined columns designated for accounts, weights, money, and signature, which bears characteristics of the ‘maktab’ literacy—extra textual features such as the layout, and conventions of presentation also contain meanings in addition to the content of language. The hidden knowledge of lists, tables, format, and layout that was learned from the ‘maktab’ and which helped to establish the ‘commercial’ literacy was not valued and taught in government schools; hence the ‘maktab’ better prepared people for the ‘commercial’ uses of literacy (Street 1984, 1995). Street also noticed that “there was also a deep ambivalence among villagers towards the state education system and the forms of literacy it transmitted” (1995:39), due to the conflicting values and interests on the part of urban educators and local villagers<sup>5</sup>. Street’s study illustrates that literacies acquired in different contexts can take very different shapes, and play very different roles in social life, and that it is therefore inappropriate for them to be evaluated and examined on the assumption that there is one universal form of literacy, based on western traditions. Only through the study of how people acquire certain forms of literacy and apply them in the concrete and specific social contexts and practices is it possible to understand the meanings and consequences of literacy.

Another well-known study in this tradition is the investigation by Barton and Hamilton (1998) of a literacy project in a community in Lancaster, England. They examined people’s everyday literacy practices, and the values and attitudes behind them. Through in-depth interviews, observations and document collection and by attending to the particulars of people’s doings with regard to reading and writing of various types, they present a rich and vivid picture of a (basically working-class) people’s literacy life in a local community in the north of England—how literacy is used to make sense of life,

---

<sup>5</sup> Villagers feel that urban teachers show more interest in urban advancement than in educating rural villagers, and made no effort in understanding rural values and material needs (Street 1995:39).

to get things done in the community, to fulfil personal goals, to meet emotional needs, etc. For instance, one informant viewed writing at work as a struggle since he didn't get trained sufficiently for this at school and hence viewed himself as uneducated; he viewed reading "authentic war stories" and writing his own "authentic war stories" as one of the pleasure of his life; another informant used literacy as a tool to solve community affairs, to help friends or neighbours solve their problems, to help her son fighting against dyslexia, and to bring changes to her life. The study shows that literacy has different meanings for different people; that the study of literacy cannot be distanced from the real-life social context in which it takes place; and that it is closely related to the personal, social and cultural history of its users.

Literacy studies of these kinds have revealed a very different picture from what was portrayed by the autonomous model, and at the same time refuted the fundamental assumptions underpinning it. As was mentioned at the beginning of this section, the 'autonomous' model of literacy tends to be based on western 'essay-text' literacy—a cultural-specific literacy practice, whose characteristics were treated by some scholars (see Goody and Watt 1988, Olson 1988, Ong 1988 for example) as 'the' characteristics of literacy. The studies reviewed above have shown the inadequacy of this model of literacy and point to a new direction of literacy studies based on the 'ideological' model of literacy. Street (1993b) terms studies based on the ideological model of literacy as new literacy studies (NLS), and I will use the two terms interchangeably hereafter. The basic tenets of the 'ideological' model of literacy or NLS include: there is no one single literacy but multiple literacies associated with different domains of social life and different social institutions; the meaning of literacy depends upon the social institutions/contexts in which it is embedded and upon the processes whereby reading and writing are learned (Barton 1994; Baynham 1995; Gee 1996, 2000; Street 1984,

1995). Therefore, from this point of view, in order to make sense of any given literacy practice (e.g. academic reading), one should study it in the social contexts that give it meaning (Street 1995).

### 2.2.3 NLS in Academic Literacy

There has been an expanding body of research studies in the area of academic literacy guided by the NLS theorisation of literacy (Ivanič, 1997; C. Jones, Turner, & Street, 1999; Lea & Stierer, 2000; Lea & Street, 1998; Lillis, 2001). However, nearly all of this has been concerned with academic writing; there have so far been very few research studies on academic reading that explicitly make use of the NLS theorization. Nevertheless, some researchers do conceptualize academic reading in a similar way as those who adopt NLS framework. For example, Mann (2000)<sup>6</sup> focuses on native English speaking UK university undergraduate students' experiences of reading and explores the meanings of reading in the students' lives in general and in their academic life at the university and how that shapes the students' approaches to reading. Her findings include that such students define the seemingly same reading tasks differently and assign different meanings to reading and to the academic context (e.g. one student sees academic reading as "intellectual activity", involving "concentration and engagement", from which she tries to work out her own ideas; and she sees universities as places for intellectuals where she feels safe and at home, as she views herself an intellectual. Another student, in contrast, thinks reading "a waste of time" and academic reading "not intrinsically meaningful and enjoyable"; being at university means to her more as a symbol of higher social status than a place for academic learning (p.303-306)); that the significance of academic reading for each student relates closely to his/her perception of themselves as a student and as a person; and that reading in academic

---

<sup>6</sup> See Chapter 1 (1.2) above for further discussion of this source.



context is not a private and personal activity but a public and evaluated activity, thus is often experienced by the students as ‘disturbed’ or ‘problematic’ not because of the actual reading process, but because of the purposes and consequences of the reading activity that is imposed upon the students by more powerful parties in the academic context. Although she does not mention anything in relation to NLS, her view of reading as meaningful in different ways to different people and within different contexts, as closely associated with personal history, and as social rather than individual and private, reflects very closely a number of features of the NLS theorization.

While Mann’s (2000) study is concerned with native speakers of English, Bell focuses on the reading practices of Thai postgraduate students in an Australian university (J. Bell, 2002, , 2005). She explores the cultural-educational difference between the Thai and Australian education systems, and how that shapes students’ reading practices before and after they started their studies in Australia. She holds that the students’ past literacy experience, cultural and educational background and the contexts in which their literacy practices take place, are crucial to our understanding of reading and hence must be taken into account while researching reading, which, once again, closely echoes the NLS theoretical perspective. Her study demonstrates that the conception of reading and hence the educational expectations in these two countries differ from each other, which resulted in different reading practices; and that the academic environment plays vital roles in shaping students’ reading practices.

Taillefer (Taillefer, 2005), through a questionnaire survey of European undergraduate exchange students in three countries (Britain, France and Spain), illustrates that difference in academic literacy culture exists even among western countries (cf. Sherman, 1992), and that such difference in academic literacy culture leads to distinct reading practices in these three countries, which echoes Bell’s

arguments and conceptions of reading (2002, 2005). Taillefer's study once again reflects some basic ideas of NLS by showing the necessity of considering students' home literacy culture and past literacy experiences in the study of L2 literacy practices, and of considering the differences between literacy cultures and the part such differences can play in students' literacy practices.

To sum up, the three studies mentioned above show that academic reading cannot be fully understood from an autonomous view of literacy discussed in 2.2.1 above, since, as the literature just reviewed show, reading *per se* may not be problematic, i.e. the students are not necessarily deficient in reading skills or strategies. Rather, it is the changes in the academic environment and differences between the host culture and the student's home culture that need to be studied in order to understand their reading practices. Although not explicitly using NLS theories to guide their studies, their theorization of reading and literacy nevertheless reflects some of the essential tenets of NLS, which have been steadily developed and improved over years by various researchers from areas of education, anthropology, linguistics, etc. However, without a comprehensive theory of literacy, such as the NLS framework, to guide their studies, none of the three researchers mentioned above was able to cover all the aspects that are essential to a full understanding of literacy.

By foregrounding NLS theories of literacy in my study of academic reading, I am therefore explicitly and systematically applying the whole set of the key arguments and concepts to my study, rather than grasp only one or two aspects as Mann (2000), Bell (2002, 2005) and Taillefer (2005) have done in their studies. Moreover, the authors mentioned above still have the individual readers and their knowledge and strategies of reading as the focus of their studies. For instance, Mann (2000) only examined the relationship between the students' academic reading experiences and their

self-perception as a student and as a person; Bell (2002, 2005) mainly examined how Thai students' cultural and educational background have influenced their reading strategies and approaches, and how they changed their reading strategies and approaches in an Australian university; Taillefer (2005) only used questionnaire to examine students' home academic literacy culture. The current study, instead, will emphasize the interactions and relationships between the individual and the context, and between the past experiences and current practices. In other words, I will examine the students' past education and literacy experiences as the current practices are very likely built upon the personal history of literacy experiences; I will examine all the literacy events that are potentially relevant to the students' academic reading for the purpose of writing assignments; I will then examine how the students interact with the other people involved in the events, how they interact with the physical, institutional, and sociocultural contexts, how their relationships with other people and with the contexts may have effects on their academic reading practices, and how their academic reading practices may have effects on their academic writing and their experience of being part of the academic discourse community in a UK university. In so doing, I am hoping that the current study will contribute to both our understanding of reading and to the further development of NLS by applying it to a field of study where there seem to have been relatively few studies adopting NLS tradition.

### **2.3 Working Concepts in the New Literacy Studies (NLS) Approach**

As I have already made clear that this research takes the view that it is important to relate academic reading practices to social context, I have also indicated that the NLS conceptual framework appears especially suitable for providing such a perspective. I will therefore now review the basic concepts of NLS that are central to a study of the kind this research is concerned with.

### 2.3.1 Literacy Events

A “literacy event” is defined by Anderson et al. as “any action sequence, involving one or more persons, in which the production and/or comprehension of print plays a role” (1980, quoted in Heath, 1983:386). As Heath puts it, “those occasions in which the talk revolves around a piece of writing” are literacy events. Such definitions imply that the interactions between the participants are based on a piece (or pieces) of writing—either to produce or to comprehend; and that the piece(s) of writing are very likely to play a central role in the interaction.

Barton extends this concept to include any occasion where “the written word has a role” (Barton, 1994:36). For example, parents reading a story to children at bed time, two friends talking about a newspaper article that they both read before, writing a shopping list, taking a telephone message, students reading textbooks are all seen by him to constitute literacy events. Ivanič (1997) provides further understanding of this concept, arguing that the text may either play a central or a peripheral role in an event; that one or more texts may be involved in an event, or a text may be involved in more than one event or may be involved in an event in more than one way; and that an event may be divided into sub-events (p.63). It is the literacy event in this broad sense that I will use in the current study of academic reading. Therefore, any occasion where the written word has a role for the purpose of reading for writing an academic assignment will be considered as a relevant literacy event. For example, going to the library to borrow books, searching the library catalogue and/or Internet database for references, looking at the reading lists, talking to others about the reading and writing tasks, emailing tutors asking questions concerning reading, and so on, are all considered relevant.

The advantage of studying literacy in terms of literacy events is that the concept

reflects the social nature of literacy. It foregrounds the relationship between reading and/or writing and the particular and specific occasion which is related to reading/writing in some way. Since “reading and writing are not undertaken for their own sake but in order to fulfil social goals” (Ivanič 1997:62), it is not sensible to study them in isolation or as only concerned with individual cognitive processing. It is necessary to take into account the social factors surrounding and related to reading and writing which give rise to and assign meanings to particular activities of reading and writing. In this regard, the concept of ‘literacy event’ can serve as a useful means for studying literacy as it is situated in specific occasions and activities in human social life, the overall perspective that my research is concerned with.

### **2.3.2 Literacy Practices**

However it is not sufficient to look just at specific events, in which people use literacy. It is also important to find out why the events appear the way they are. For example, from my experience both as a student and university teacher in China, and on the basis of anecdotal evidence provided by colleagues with similar experiences, it appears that many Chinese students seldom used the library as a source of reference books during their university studies in China. On the other hand, students in UK universities are expected to use the library on a regular basis in order to obtain resources for their essays (cf. Sherman 1992; Taillefer 2005). To understand why the same students may involve in different literacy events while studying in China and UK, we need to go beyond these specific literacy events. Another concept—literacy practices—is introduced for this purpose.

Baynham and Baker (2002) summarize three usages of the term ‘practice’: firstly, the everyday usage of practice as doing something repetitively to improve skills; secondly practice as in contrast to theory; and thirdly practice as “situated human

activity”—i.e. “incorporating both what people do and the ideas, attitudes, ideologies and values that inform what they do” (Baynham & Baker, 2002:2). They suggest that it is the third usage of practice that is currently referred to in NLS. For instance, Street (Street, 1993b:83) uses the concept of literacy practices to indicate the social uses and meanings of reading and writing beyond the level of literacy event. Barton sees literacy practices as the “general cultural ways of utilizing literacy which people draw upon in a literacy event” (1994:37), which “involves values, attitudes, feelings and social relationships”, and “includes people’s awareness of literacy, constructions of literacy and discourses of literacy, how people talk about and make sense of literacy” (Barton & Hamilton, 1998:6). For example, when students searching references in addition to the recommended reading lists from the tutors in the library or through the Internet, this constitutes a literacy event; the literacy practice involved in this event can be described as doing extra reading beyond the required or recommended reading lists. Such practices may very likely involve beliefs in the value of extensive reading in learning or achieving academic goals, or people’s positive attitudes towards extensive reading, or students’ past experiences in similar situations where they got rewarded by tutors (a more powerful party than the students) for doing extra reading, or students’ gradual realization that tutors’ reading lists may not always be adequate for every student’s purpose.

Another example is Thai students’ use of dictionary while reading (Bell 2005). The literacy event can be a Thai student consulting English/Thai dictionary while reading an academic text. The literacy practice here can be using native language to help reading comprehension in a foreign language, which, according to Bell (2005), is rooted in the way Thai students learn English in Thailand—i.e. by translating English sentences into Thai and vice versa—which very likely leads the Thai students to the reliance on their

native language in L2 reading. Bell (2005) also reports that after studying in Australia for some time, some Thai students that she researched showed changes in this practice as they realized the limitation of the dictionary definitions in helping them with reading tasks in an Australian university, where the requirements and purposes of reading differ from their home universities.

These two examples above may have shown how literacy practices involve values, attitudes, beliefs, cultural upbringing, etc. and how literacy practices may be constructed/reconstructed in relation to wider literacy discourses or social contexts. Literacy practices are always and probably can only be embodied in and realized through concrete literacy events, yet the concept of literacy practices “is pitched at a higher level of abstraction and refers to both behaviour and the social and cultural conceptualizations that give meaning to the uses of reading and/or writing” as Street puts it (1995:2). The above discussion also seems to show that the concept of literacy practice, as well as the concept of literacy event is also a reflection of the social nature of literacy, as Barton and Hamilton claim that “literacy practices ... include processes internal to the individual, ... social processes which connect people with one another, ... and shared cognitions represented in ideologies and social identities” (1998:6-7). Therefore, this concept serves as another central working concept for my research because I would not only like to investigate the literacy events in which the Chinese postgraduate students engage, but also to understand the underlying forces which drive them to engage in those literacy events.

### **2.3.3 Context**

My aim of this study is to look at literacy in context, therefore, it is inevitable and essential to consider the concept of ‘context’ in order to make meaningful discussion of literacy events and literacy practices in the current study. The concepts of literacy event

and literacy practices both point to a social theory of literacy, which emphasizes the embeddedness and situatedness of the individual activity of reading and/or writing in the wider social contexts, or in other words, the relationship between the individual and the social world, and emphasizes the concreteness and particulars of the occasions where reading and/or writing is involved in some way that may be of interest to researchers. As Goodwin and Duranti have observed, “context has long been a key concept both in the field of pragmatics and in ethnographically oriented studies of language use as well as quantitative ones” (C. Goodwin & Duranti, 1992a:1). Literacy studies, as a branch of studies of language use, also inevitably involve the notion of context, which various researchers have considered in their discussions (Barton, 1994 (by using the term 'environment'); Baynham, 1995; Gee, 1996; Ivanič, 1997; Lillis, 2001).

### ***2.3.3.1 Language in Context***

Literacy is closely associated with language. Baynham (1995) remarks that literacy is often collocated with language in public discourse. Ivanič explores the relationship between language and literacy, arguing that literacy is ‘less’ than language because literacy is basically concerned with written language, whereas language includes both written and spoken forms; and that literacy is ‘more’ than language in the sense that researchers working in the NLS tradition pay more attention to the “physical, mental and social practices and processes in which written language is embedded” than to the language itself (1997:57). It is quite common and natural to talk about language in the discussion of literacy (e.g. Barton 1994; Baynham 1995; Gee 1996; Ivanič 1997). Therefore, I will next discuss a theory of language in context and then move on to that of literacy in context.

It was Malinowski who first brought forward the importance of context beyond the



words and sentences immediately before and after the particular sentence that one is looking at in order to fully comprehend the sentence in question. From his ethnographic field work in Eastern New Guinea, Malinowski found that to understand an utterance, “the listener, whom we suppose acquainted with the language, ... would have first to be informed about the situation in which these words were spoken” (1923:301), or in other words, what was happening around while these words were spoken. He thus coined the term ‘context of situation’ to indicate “on the one hand that the conception of *context* has to be broadened and on the other that the *situation* in which words are uttered can never be passed over as irrelevant to the linguistic expression” (Malinowski, 1923:306, emphasis in original). He then went on to argue that after being informed about the ‘context of situation’, the listener should also “have them [these words] placed in their proper setting of native culture” (Malinowski 1923:301)—i.e. to fully comprehend the utterance, one should take into account the cultural condition within which the utterance is produced. Later on, Halliday gives this notion the term ‘context of culture’ (Halliday & Hasan, 1989).

Halliday further developed the concept of ‘context of situation’ after examining the works by Malinowski (1923), Firth (1935, 1950), and Hymes (1967). Halliday defines ‘the context of situation’ as the immediate environment where language is used, consisting of three components:

Field of discourse: the ‘play’—the kind of activity, as recognised in the culture, within which the language is playing some part [predicts experiential meanings];

Tenor of discourse: the ‘players’—the actors, or rather the interacting roles, that are involved in the creation of the text [predicts interpersonal meanings];

Mode of discourse: the ‘parts’—the particular functions that are assigned to language in this situation, and the rhetorical channel that is therefore allotted to it (e.g. is it persuasive, expository, didactic, etc.; is it spoken, written or some combination of the two) [predicts textual meanings] (Halliday and Hasan 1989:12, 46).

The ‘context of culture’ refers to the broader cultural background from which meanings

are derived, as Halliday argues that “any actual context of situation, the particular configuration of field, tenor, and mode that has brought a text into being is not just a random jumble of features but a totality—a package ... of things that typically go together in the culture” (Halliday and Hasan 1989:46). However, Halliday did not give a more concrete and specific definition of the ‘context of culture’.

Drawing upon Halliday, Fairclough (1989) expands the theory of context into a theory of language as discourse—a form of social practice. He uses the following diagram to illustrate his theory (see figure 2.1 below). His discourse view of language as a form of social practice configures language at three levels: he views language/discourse, firstly as a product, i.e. text (both in written and/or spoken form), which is represented by the inner layer—‘text’ in figure 2.1 below; secondly as processes (represented by the middle layer in figure 2.1 below), which involves “an interplay between the properties of texts ... and people’s knowledge of language, representations of the natural and social worlds they inhabit, values, beliefs, assumptions, and so on” (Fairclough 1989:24); and thirdly as involving social conditions—the outer layer, in which the text and the processes of production and interpretation of the text are embedded. Fairclough relates the social conditions to three levels of social organization. The level of the social situation or the immediate social environment can be seen as an equivalent of ‘context of situation’ in Halliday’s term. Fairclough further divides Halliday’s ‘context of culture’ into the level of social institution, and the level of the society as a whole (1989:25). This diagram in figure 2.1 below shows that “a text is inextricable from the processes of production and interpretation which create it, and that these processes are in turn inextricable from the various local, institutional and socio-historical conditions within which the participants are situated” (Ivanič 1997:41). Ivanič adds the arrows in order to make it more explicit

that language both shapes and is shaped by the social context (Fairclough 1989:23, Ivanič 1997:43).

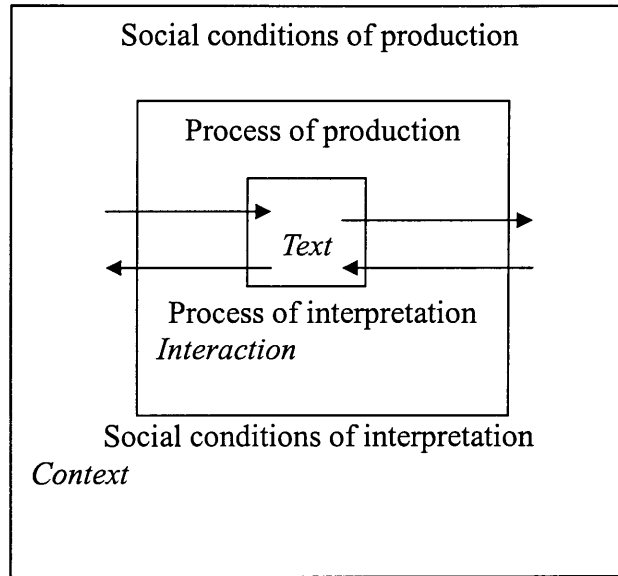

Figure 2.1 Discourse as text, interaction and context (Fairclough 1989:25), arrows added by Ivanič 1997.

To sum up, “in seeing language as discourse and as social practice, one is committing oneself not just to analysing texts, nor just to analysing processes of production and interpretation, but to analysing the relationship between texts, processes, and their social conditions, both the immediate conditions of the situational context and the more remote conditions of institutional and social structures” (Fairclough 1989:26).

As literacy involves language and texts (Ivanič 1997), Fairclough’s (1989) discourse view of language as a form social practice captures the main features of NLS’s theorization of literacy as social practice, and hence has been adopted by researchers in NLS tradition to conceptualize ‘literacy in context’. In the following part, I will discuss the ways in which Fairclough’s (1989) theory of language in context has been applied in literacy studies.

### **2.3.3.2 Literacy in Context**

Barton (1994) adopts the notion of language as discourse, maintaining that in the

study of literacy what must be covered is broader than just discussing linguistic form of particular registers or genres. Building on such a theory of language, he develops an ecological view towards literacy, the central propositions of which reflect Fairclough's theory of language as discourse and social practice, and further spell out the implications of Fairclough's ideas in literacy studies.

Barton contends that firstly literacy is a social activity that should be studied in terms of literacy events—concrete and particular occasions where people do things with written texts. Thus, a connection can be established between this perspective and Fairclough's model (see figure 2.1 above) as follows. Study of literacy as events implies analysing the interactions between people and between people and texts during the process of producing and/or interpreting the texts, and analysing the relationship among people involved in the event, and between the people and texts. This echoes Fairclough's argument that to understand language as discourse involves analysing not only texts and processes of production and interpretation, but also the relationship between texts and processes, and the interaction during the processes of production and interpretation (1989) (represented by the inner and middle layers of figure 2.1 above). Studying literacy at the level of literacy event also involves the immediate social context—'context of situation', which is part of the outer layer in figure 2.1 above.

Secondly, in addition to literacy events, as I have already argued (see section 2.3.3 above), literacy should also be studied as literacy practices, and this brings in the rest of the outer layer in figure 2.1, i.e. the context of social institution and the society as a whole. Barton further elaborates that there are different literacies that people make use of and that are associated with and supported by different social institutions. For instance, the literacy practices involved in reading and writing academic texts are typically associated with higher education and academic institutions such as a

university, and will be very different from those involved in home literacy associated with family life (e.g. bed-time story reading). If one is to make sense of academic literacy, it is necessary to study the academic institution and the wider social conditions in which the academic institution is situated.

In addition, Barton also specifies that the “broader social relations” literacy involves consist of people’s values, attitudes and awareness of literacy, as people’s attitudes toward literacy and the relative importance they attach to literacy will often have an effect on their literacy practices (1994:47-8). Moreover, he argues that the consideration of social context must include a historical dimension, i.e. literacy has a history both at the personal level and at the social level. The first level of history refers to the personal history of literacy learning and development from childhood throughout one’s life. As Barton notices from the Lancaster Community Literacy Project, people’s view about literacy and their choice concerning reading and/or writing at any one point of time is very much based on the possibilities provided by their past experiences; and literacy learning takes place throughout one’s life time as the personal life demands, social circumstances, technologies, etc. change. And the second level refers to the literacy changes in the whole culture. As my study is concerned with Chinese postgraduate students who came to UK for a one-year master’s programme, my main concern is the students’ personal history of literacy, rather than the social history of the development of academic literacy in UK higher education. Therefore, I will not elaborate the second level of literacy history.

Barton’s (1994) theory of literacy in context draws upon Fairclough’s idea of the inextricability of language/discourse from both the immediate and wider social conditions, and develops the concepts of literacy event and literacy practice for literacy studies, reflecting the embeddness and situatedness of literacy in the social context. He

thus breaks down the boundary between the middle and outer layers in Fairclough's diagram (figure 2.1 above) and spells out some important aspects of context at the level of social institution and at the level of whole society to help our understanding of literacy. However, Barton (1994) does not provide a diagrammatic representation of his theory, and it is Ivanič (1997) who combines the thinking of Barton (1994) and Fairclough (1989) and develops a model of literacy in context (see figure 2.2 below), which has since been quite widely adopted and applied among researchers of NLS.

Drawing on Barton's (1994) theory of literacy in context, and Fairclough's (1989) diagram (see figure 2.1 above) of discourse, Ivanič (1997) develops a diagram to represent literacy in context, showing the relationship between literacy event, literacy practice and the social conditions (see figure 2.2 below). The 'text' remains the innermost layer in this model, indicating the inevitable presence and role of written texts (be it central or peripheral) in any literacy event.

However, it is the second layer—'literacy event'—that is more of interest for researchers in the NLS tradition (see 2.3.1 above for the advantages of studying literacy event). The concept of literacy event already involves the context of situation, which is further specified by Ivanič as including firstly "physical situation ... an example from academic writing (can be) ... (a student's) bedroom ... (with) books, lecture notes ... (a tutor's) office ... with piles of essays, computer ..."; and secondly "specific purposes and interpersonal relationships", e.g. the event of a student writing an assignment involves purposes of writing a specific assignment from the student's point of view and the tutor's point of view, the student's guess of tutor's intention of setting the assignment or tutor's expectations for the assignment, tutor's evaluation of the student's written work, and so on (1997:59-60).

The outer layers of figure 2.2 below represent the social context or context of

culture, matching the outer layer of Fairclough's diagram (see figure 2.1 above). Ivanič divides the social context into two levels: the third layer represents "the conventions on which people are drawing in the literacy event: practices, the conventions for behaviour, and discourse types, the conventions for language use", more or less corresponding to Fairclough's social conditions at the level of institution. The outer layer refers to "the socio-cultural context which shape practices and discourse types: the configuration of values, beliefs, interests and power relations" (Ivanič 1997:64).

Ivanič's diagram incorporates the two most important concepts in NLS, i.e. literacy event and literacy practice, with Fairclough's theory of discourse, which shifts the focus on text only to include analysis of social relationships and social conditions, thus establishing a model of exploring different levels of context in literacy studies, in her own case the study of academic writing and writer identity in particular.

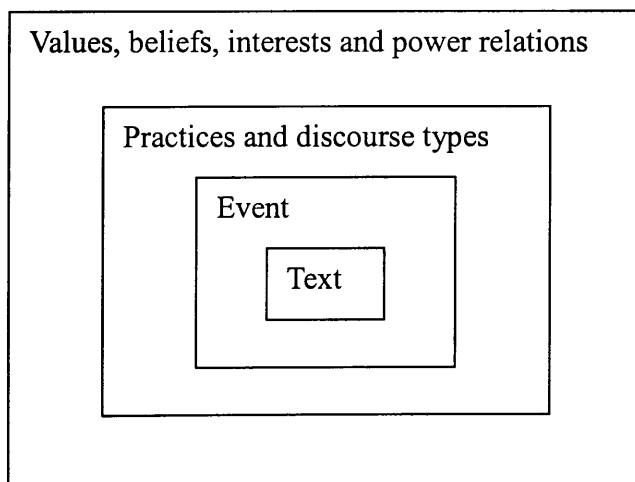

Figure 2.2 Literacy in context (Ivanič 1997:64).

The appropriateness and effectiveness of this model in the study of academic literacy has been illustrated by Ivanič's studies of academic writing in UK higher education (1997). Due to its comprehensive and integrated nature, and the close relationship between academic reading and academic writing in students' academic life at universities, it seems reasonable to assume that Ivanič's model is also relevant to and

useful for the study of academic reading. It has therefore been used to investigate the context of the aspects of academic literacy focused on in my study.

### 2.3.4 Network

In a theory of literacy as social practices, it is inevitable to analyze interpersonal relationships and the role such relationships play in literacy, as has been made clear in sections 2.3.1, 2.3.2, 2.3.3 above, and it has therefore seemed important to also make use of concepts related to this aspect of literacy in my study. As Barton and Hamilton (1998) point out, “the strength of the notion of networks is that it provides a simple way of moving beyond a focus on individuals and individual encounters, towards one which shows how literacy links across people and localities” (p.16). Therefore, the concept of network is often taken for the purpose of studying interpersonal relationships by various literacy researchers (Barton & Padmore, 1991; Fingeret, 1983, Barton 1994, Barton and Hamilton 1998; Gee, 2004).

A “network”, according to Boissevain, is “the social relations in which every individual is embedded” (1978:24). Figure 2.3 below is a simple illustration of Boissevain’s idea of social networks. The central circle with a letter ‘a’ is the person in question. The boxes with letters in are other people, and the lines represent social relations, such as family, relatives, friends, colleagues, etc. Persons ‘b, c, d, e, f’, who are connected with ‘a’ directly, form the “first order or primary network zone”; others, i.e. ‘g, h, i, j, k, l’, who are not directly connected to ‘a’, but may be in contact with ‘a’ through members of the first order zone, form the “second order zone” (ibid).

In literacy studies, Fingeret (1983) talks about two types of relationships in the social networks of a group of illiterate adults: ‘interdependent’, meaning that individuals both contribute to and get support from their networks, and ‘dependent’, referring to those who cannot help others with literacy but always get help from the



networks. Barton and Hamilton (1998) focus on different functions that social networks can fulfil in literacy activities, such as ‘getting things done in groups’, ‘finding out information’, ‘providing mutual support’ (p.16).

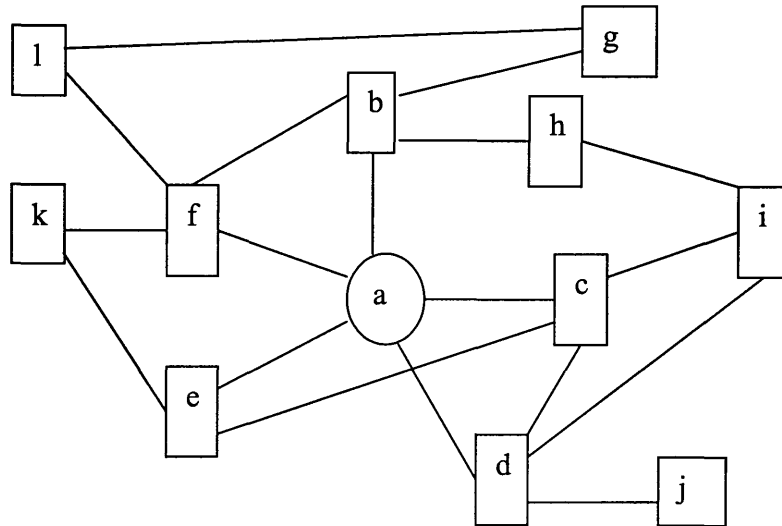

Figure 2.3 social networks (developed from Boissevain 1978)

They also argue that besides the positive effects of networks on individuals, networks can also be ‘oppressive, disruptive or resistant to individuals’ needs for change’ (ibid). For example, their study of community literacy shows that people’s wish to return to education may be resisted by family members, or by a circle of friends. Lillis (2001) illustrates hostile attitude of family members towards academic literacy events at home (e.g. the husband of one of the informants turned the light off when he saw his wife (a mature student in higher education) trying to do academic reading and writing at home, and other family members wanted her to spend time with them at home instead of doing reading and writing on her own). Thus, a network of social relations inevitably involves issues to do with power, roles and identity. In my study, I have therefore chosen to explore both supportive and non-supportive relations among the social networks, as both may make a difference in people’s literacy practice. In addition,

I have not restricted the investigation in the first order zone (i.e. networks by direct contact) only, but have also considered both direct and indirect relations in the network which may play a role in people's literacy practices.

### **2.3.5 Ruling Passions—the Emotional Dimension in Literacy Practices**

Literacy events and practices involve an emotional aspect, as has been shown by various researchers. For instance, Horsman (Horsman, 1994, , 2000), in her teaching and research of adult literacy, finds that many female adult learners of literacy associate literacy learning as a trigger for memories of failure of literacy learning in childhood, and for memories of violence at home and school as a child. She also points out that “literacy learning may be the first return to a school-like situation for many learners, and that, in itself, may be terrifying and lead to panic” (Horsman 2000:5). Rockhill shows the strong desire on the part of women to learn to be more literate or to return to education in order for change of their current lives, and the threat that their changes bring to men as well as the threat from the new situations to the women themselves (Rockhill, 1993). Besnier's (Besnier, 1993, , 1995) study indicates that letters (or written texts in a broader sense) can be “heavily affective”, conveying emotions such as “love, empathy, compassion, happiness, unhappiness”, etc. (1993:72-73). Barton and Hamilton (1998) find in their study that “the opening of mail in the mornings can be experienced as threatening as people deal with bills; other letters, in the form of love letters and consumer catalogues, can also embody dreams, fantasy and desire” (p.18). They also identify other strong feelings people have about literacy: “disapproval, triumph, control or mastery, stigma, fear” (ibid). They used the term “ruling passions” to refer to people's strong feelings toward literacy, or strong feelings that people associate with literacy (e.g. things, feelings, emotions, etc. that drive people to do reading and/or writing, and that people keep mentioning while talking about literacy).

Drawing upon Barton and Hamilton's notion of ruling passions, Baynham (2001) demonstrates the powerful role the passions for geology and weather has made the subject enthusiastic about "reading the weather, reading the media text of the weather report, reading and recording the rainfall" (Baynham, 2001:311).

I have felt it important to make use of the concept of "ruling passions" in my study of Chinese students' academic reading as I believe that their academic literacy experiences will inevitably involve an emotional dimension, which should not be overlooked in a study of literacy. For instance, a long reading list may appear daunting to them, hence may make them panic even before they start reading. By the use of the concept of ruling passions, thus, I will be able to refer to students' strong feelings toward literacy in general and toward academic literacy in particular, their feelings and emotions while talking about literacy experiences, and the feelings and emotions they experience while doing academic reading and writing. In short, this concept will enable me to include instances in the students' academic reading practices that involve some kind of emotions and feelings and try to see what effect they have on students' academic reading.

### **2.3.6 Community**

There are two commonly used senses of 'community' in NLS. One is defined in "geographic terms": e.g. Street's (1984, 1993, 1995) study of literacy practices in an Iranian mountain village, Heath's (1983) study of three communities in Carolina US, Barton and Hamilton's (1998) study of a working class community in Lancaster UK all refer to community in this sense. Although I have used the term 'geographic' to characterize the sense of 'community', in fact, the meaning also carries with it the notion of 'settledness', i.e. of a community rooted over an extensive period of time in a particular location. The other meaning often has the sense of 'discourse community',

which, as Barton puts it, is defined by “having a set of common interests, values and purposes. ... members have agreed common knowledge ... common ways of using language ... common ways of acting in relation to knowledge” (1994:57). Ivanič points out that there is the more abstract element in this term, relating to “the context of culture, the socio-historically produced norms and conventions of a particular group of people”, and the more concrete element, relating to “the identities, values and practices of real individuals”, both of which need to be borne in mind (1997:78).

However, for the purpose of my study, I find neither definition quite suitable. The focus of the study is on a group of Chinese postgraduate students in a UK university; hence they do not seem to fit the first definition of community in geographic terms. Also, in a sense, this group of students are new-comers to an academic discourse community, who may not have the same shared knowledge as other members. Therefore, the second definition does not seem helpful, either. Instead, therefore, I will argue that the use of the term ‘community’ as in the Activity Theory is more useful for my study, and this concept will therefore be discussed within the next main part of this chapter.

### **2.3.7 Summary**

In section 2.3 above, I have illustrated how the basic working concepts of NLS can help me conceptualize academic reading as social practices, and establish a framework of analyzing academic reading with essential aspects that need to be considered in a social view of literacy.

The focus of my study is to investigate Chinese postgraduate students’ academic reading practices in relation to their written assignments. The whole process of reading for the purpose of writing an assignment lasts over a period of time ranging from a few days to a few weeks, involving a series of inter-related literacy events. In order to keep

in mind all the relevant aspects of literacy practices involved (such as events, practices, context, histories, networks, ruling passions, community, etc.) at the same time as the analysis of the whole reading process, a more concrete framework is needed, in order to weave different aspects into one picture and to explore contributing factors of the literacy practices. Thus, in the following, it will be argued that “Activity Theory” (see Engeström 1987, 1990, 1999; Blackler et. al. 1999, 1999a, 2000 amongst others) can serve such a purpose. In the next section, I will therefore explicate the compatibility of the NLS and Activity Theory (AT) frameworks, the basic arguments of the AT and the main analytical tool involved—the “activity system” (AS). I will also discuss advantages and suitability of AT for my study.

## **2.4 Activity Theory (AT) Approach to the Study of Literacy Practices**

### **2.4.1 Common Theoretical Root of NLS and AT**

NLS and AT both share a common theoretical ground, i.e. the Vygotskian cultural-historical school of psychology, which, in turn, finds its root in Marx and Engels’ works (Karl Marx & Engels, 1975). It is widely acknowledged that AT has its most central concept of ‘activity’ developed out of Marx’s theses on Feuerbach (Marx and Engels, 1975); and that the main analytical tool for the AT—the activity system (AS), and the claims about the social origin of human mind, all owe debts to Marx (see for example Bourdieu, 1977; Engeström, Miettinen, & Punamäki, 1999; Scribner & Cole, 1981; Wertsch, 1985). I will provide a detailed discussion of AT later. However, the connection between the NLS and Marxist theories is far less visible and well-known, but nevertheless exists. Scribner and Cole’s (1981) study of literacy uses by Vai people in Africa, one of the early works that set the cornerstone for the development of NLS and *the* work that first brought forward the concept of ‘practice’ in literacy studies, drew heavily on Marx’s works and Vygotskian school of psychology for the research design

and interpretation of data. Inspired by Marx and Engels' statement about human-environment interaction—that man (sic) transforms physical nature in labour activity with the use of tools, and in the process of tool use, he transforms his own nature—Vygotsky argues that the concept of “tool” includes cultural tools such as language, writing, number system, etc. and such tools are “products of specific conditions of social development” and have significant consequences for the transformation of intellectual processes (Vygotsky, 1978:38-39). In this way, Vygotsky establishes a link between society and mind, which helps the investigation of the social origin of human thought. Based on this theorization, Scribner and Cole propose a “practice account of literacy” to understand how “socially organized activities may come to have consequences for human thought” (1981:235). Their notion of practice is derived from Marx and Engels' concept of tool-mediated activity mentioned above, which refers to “a recurrent, goal-directed sequence of activities using a particular technology and particular systems of knowledge” (ibid:236). Guided by this concept, they approached literacy as

a set of socially organized practices which make use of a symbol system and a technology for producing and disseminating it ... instead of focusing exclusively on the technology of a writing system and its reputed consequences (“alphabetic literacy fosters abstraction,” for example)... The nature of these practices ... will determine the kinds of skills (“consequences”) associated with literacy (Scribner & Cole, 1981:236).

Barton (1994) also refers to Vygotsky (1978) while exploring the roots of literacy, drawing mainly upon his theory of learning through interaction with more knowledgeable people in social activities. Accordingly, Barton (1994) argues that “literacy is embedded in the oral language and the social interaction of the child's surroundings ... first experienced by the child as social activities, for example between the child and its care-givers. The child or adult (any person learning) gradually builds upon existing knowledge and abilities, which become transformed by the new learning” (p.130-134). Barton further points out the importance of studying the situations where

literacy learning takes place, i.e. the events and activities of literacy learning and uses, and the importance of examining past experience of literacy learning and uses in literacy studies.

Gee (2000, 2000a) recognizes a number of areas in a variety of disciplines that have undergone a shift of their focus from “individual behaviour and individual mind toward a focus on social and cultural interaction” (Gee, 2000:180), among which NLS and AT are included. Although he says that disagreements exist among these schools of thoughts, he also takes the view that they seem to share the argument that “knowledge and meaning are seen as emerging from social practices or activities in which people, environments, tools, technologies, objects, words, acts, and symbols are all linked to each other and dynamically interact with and on each other” (ibid:184). He further points out that some of these “formally discrete areas are beginning to converge” in the study of literacy (Gee 2000a:195).

The discussion above, though brief, shows how the development of NLS and its basic tenets are connected to Vygotskian cultural-historical school of psychology, thus also illustrating the common ground for NLS and AT conceptual frameworks. The concepts of literacy events, literacy practices, the emphasis on the embeddness of literacy in its context of uses, and on the importance of the literacy history, etc., seem to be compatible with the basic notion of tool-mediated activity that is central to AT. Therefore, there appears to be a *prima facie* case for integrating the two theories into one study. Keating (2001) has made a successful attempt in this respect. She combines the AT (Engeström 1987, 1999), the theory of community of practice (Wenger 1998) and the theory of critical discourse analysis (Chouliaraki and Fairclough 2000) in a study of Portuguese women’s literacy experiences in London. The concept of activity helps her handle the tensions between “actual deeds and their semiotic representations”

(Keating, 2001:197), and provides her with a way of focusing both on “the individual’s developing ways with literacy and the historical changes happening within the Portuguese community (in London) as individuals participated in situated activities” (ibid:200). In the following, I will first discuss the AT and AS, and then further explore the potential advantages of the combination of NLS and AT for my study.

## 2.4.2 Activity Theory and Activity System Model

### 2.4.2.1 Action and Activity

As was mentioned earlier, Activity Theory has its philosophical roots in classical German philosophy, in the works of Marx and Engels, and in the Soviet Russian cultural-historical school of psychology (Engeström 1999). Marx’s concept of labour activity—man (the ‘subject’) by making and using tools (the ‘mediating instrument’) produces useful objects (the ‘object’)—serves as the source for the conceptualization of the term ‘activity’ in Activity Theory. Thus, Vygotsky based his triangular model of the mediated action on this concept, as is shown in figure 2.4 below.

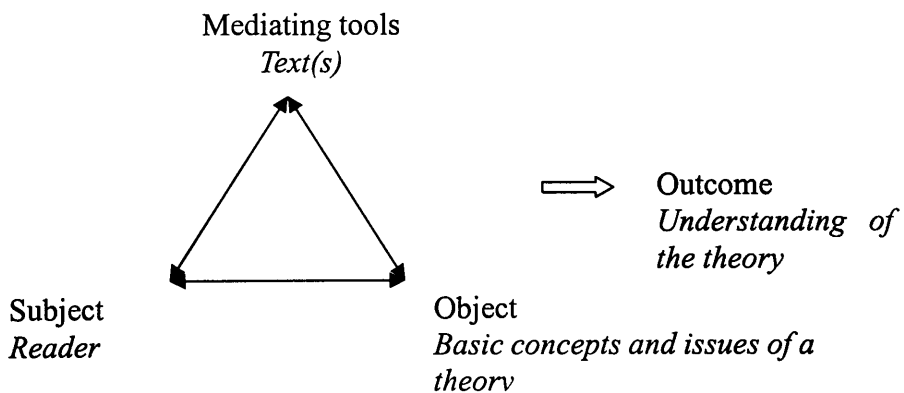

Figure 2.4 triangular model of mediated action (Engeström 1999:30, developed from Vygotsky, 1978)

The ‘subject’ is usually the human being—the active agency in any activity—which can either be an individual or group(s) of individuals. The ‘object’ is generally what the ‘subject’ is working at. It can be a material object (e.g. a table that a carpenter is



making), or an abstract concept (e.g. a theory that a student is trying to understand). “An ‘object’ is both something given and something projected or anticipated” (Engeström, 1995:397). For example, students may be asked to read about a certain theory by a certain person. The ‘object’ is partly given in the sense that the scope of reading, or sometimes even the exact texts are set aside by the tutors; and therefore students usually have some idea of what they are going to read, but they do not know exactly what they are going to work at. However, more importantly, the ‘object’ is constructed by the ‘subject’ and “gives shape and direction to activity” (ibid). In other words, even though the students are reading the same text, the ‘object’ may not be the same and hence each student reader may thus engage in a different reading activity. To use the earlier example again, a reader of an academic text may have, for example, (1) facts stated in a text as the ‘object’; (2) issues identified by the author as the ‘object’; (3) the author’s position in the debate of key issues as the ‘object’; (4) the reader’s position in the debate of key issues as the ‘object’; and so on. In each case, the reader is engaged in a different activity of reading because s/he is working at a different ‘object’. Therefore, the ‘object’ is not static, nor the same for everyone; rather, it is the product of the activity of the ‘subject’ and is only fixed when the activity comes to an end. As Leont’ev puts it, “the object of activity is twofold: first, in its independent existence as subordinating to itself and transforming the activity of the subject; second, as an image of the ‘object’, as a product of its property of psychological reflection that is realized as an activity of the subject and cannot exist otherwise” (Leont’ev, 1978:52). What he tries to say is similar to the view of Engeström (1995) mentioned above: that the ‘object’ is disclosed at the beginning of the activity, directing and transforming the activity, yet at the same time, the ‘object’ is a product of the activity of the ‘subject’, existing and being realized only within and through the activity.

Mediating tools not only include physical objects, but also culturally and historically formed artefacts, such as signs, languages, etc., employed by the ‘subject’ in order to work on the ‘object’. In the case of academic reading, mediating tools are usually texts (both in print and in digital forms), talks and discussions about texts, reading lists, lectures and lecture notes, and so on.

This triangular model of mediated actions seems to focus on individual actions, and does not entail the idea of mediation by other human beings and social relations, though such an idea is implied in Vygotsky’s theory (e.g. the role of the more experienced person(s) in the theory of the zone of proximal development (ZPD)). As Engeström (1999) argues, focusing on the level of actions exclusively makes it difficult to account for the “socially distributed or collective aspects of ... purposeful human behaviour. ... the notion of time tends to be reduced to relatively discrete slices, often described in algorithmic terms with clear-cut beginnings and ends, dictated by given goals or tasks. The continuous, self-reproducing, systemic, and longitudinal-historical aspects of human functioning seem to escape most theories of action” (Engeström, 1999:22). In answering to the inadequacy of the concept of action, Leont’ev makes his major contribution to the conceptualisation of ‘activity’ by formulating the three-level model of activity as follows, and spelling out the distinction between action and activity (1978, 1981).

Three levels		Driving forces
<i>Activity</i>	Correspondingly	<i>Motive</i>
<i>Action</i>		<i>Goal</i>
<i>Operation</i>		<i>Instrumental conditions</i>

He illustrates the distinction between action and activity by using the example of a primeval collective hunt:

A beater, for example, taking part in a primeval collective hunt, was stimulated by a need for food or perhaps, a need for clothing, which the skin of the dead animal would meet for him. At what, however, was his activity directly aimed? It may have been directed, for example, at frightening a herd of animals and sending them toward other hunters, hiding in ambush. That, properly speaking, is what should be the result of the activity of this man. And the activity of this individual member of the hunt ends with that. The rest is completed by the other members. This result, i.e. the frightening of game, etc., understandably does not in itself, and may not, lead to satisfaction of the beater's need for food, or the skin of the animal. What the processes of his activity were directed to did not, consequently, coincide with what stimulated them, i.e. did not coincide with the motive of his activity; the two were divided from one another in this instance. Processes, the object and motive of which do not coincide with one another, we shall call "action". We can say, for example, that the beater's activity is the hunt, and the frightening of the game his action (1981:210).

According to Leont'ev, activity is driven by motive, and action by goal. Activity involves a series of actions, each of which has a goal of its own. One action alone cannot fulfil the motive of the activity; yet the achievement of the goal of each action is necessary for the completion of the whole activity. The above example also shows that the 'subject' of the activity can be multiple individuals or groups.

Take reading as an example again. A student needs to read in order to write an assignment (motive). The process of looking at the reading list shall be considered as an 'action' because it alone could not enable the student to generate thoughts and words to finish the assignment. The action of looking at the reading list is driven by the goal of identifying appropriate texts to read. The 'activity' in this case is the whole process of searching and reading academic texts in order to understand and to generate ideas, which is driven by the motive of writing an assignment.

#### **2.4.2.2 Activity System (AS) Model**

Although Leont'ev's concept of activity as consisting of goal-directed actions constitutes a big step forward in the theorization of Activity Theory, drawing attention to activity as a whole rather than focusing exclusively on action, he does not provide any specific model of analysis that captures the richness of the object-oriented, culturally, historically and socially mediated activity. To overcome the limitations of the Vygotsky's triangular model of mediated action (figure 2.4 above), Engeström expands

it into a more complex model, one of what he terms the “activity system” (see figure 2.5 below). This model adds three elements, i.e. ‘rule’, ‘community’ and ‘division of labour’, to the triangular model showed in figure 2.4 above, which form the social basis of activity.

The following is a brief definition of the six components of the AS in figure 2.5 below, using Wu’s adaptation of Rathbun (1999:19).

- Subject: individual or sub-group whose agency is chosen as the point of view in the analysis
- Object: tangible or intangible, what the activity is directed at and which is moulded into the outcome
- Mediating artefacts: physical or symbolic instruments/tools
- Rule: the explicit and implicit regulations, norms and conventions that constrain action
- Community: multiple individuals and/or sub-groups sharing the same general object
- Division of labour: the horizontal division of tasks between the members and the vertical division of power and status

(Wu, 2002:43)

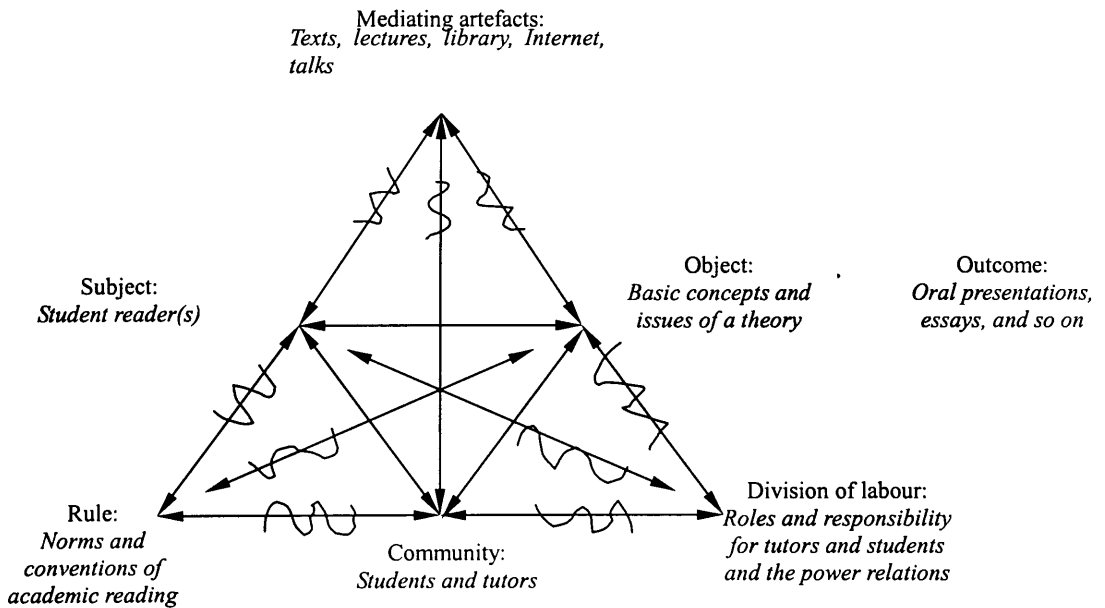

Figure 2.5 Complex model of activity system (Engeström 1999:31). Wavy lines are added by Blackler et.al. (1999a) to represent incoherencies within and between elements of the activity system.

To illustrate what this model means in concrete terms, I will use the example of reading again. The ‘subject’ might be, for example student reader(s). The ‘object’ remains the same as in figure 2.4 above, i.e. attempting to uncover the basic concepts

and issues of a theory. 'Mediating artefacts' include lectures, handouts, conversations with tutors or fellow students, academic texts, reading list, library, Internet resources, etc. which may all have an effect on the reading. The 'rule' consists of norms and conventions of academic reading in a UK university. The 'community' refers to the group of students and tutors who have interest in the particular theory, or who are required to learn/teach about the theory. 'Division of labour' consists of roles and responsibilities assigned to and taken by tutors and students, and the power relations within them. The 'outcome' of the reading activities may be an oral presentation, a written essay, and so on.

The AS model provides me with a framework to explore academic reading as an activity taking place within the activity system, and investigate the interacting factors that contribute to the students' reading practices and experiences as the activity unfolds. In addition, the AS model can integrate the key arguments and concepts of NLS framework into its own constituent components. There are a number of ways in which the AS model is compatible with the NLS concepts. Firstly, the AS reflects the NLS's idea of emphasizing the embeddedness of literacy by situating the activity in its social context. Secondly, the way in which "context" is theorized in AT, i.e. context as consisting of 'mediating artefacts', 'community', 'rule', and 'division of labour', is compatible with the context in NLS's theorization (see figure 2.2 above: Ivanič's model of "literacy in context", and 2.3.3.2 above for details of context in NLS). Thirdly, the notion of activity and the process of constructing the 'object' integrates the concept of literacy events into the analysis, as we can view a series of inter-related literacy events as constituting the activity of academic reading. A comparison between figure 2.2 and figure 2.5 above may help the points to be seen more clearly. In figure 2.2, the inner box is a "literacy event" with a text (or texts) and the immediate physical settings and other

person(s) involved in the same literacy event. In figure 2.5, the starting point is the ‘subject’—a person or a group of people engaging in certain activity, academic reading in my case; text(s) and the other physical settings become the ‘mediating artefacts’; other people whose point of view is not chosen to construct the AS, yet who are also involved in the academic reading activity, will be discussed under the category of ‘community’ in the AS. The two outer layers in figure 2.2, representing “conventions for behaviour, ... conventions for language use, ... the configuration of values, beliefs, interests and power relations” as Ivanič puts it (1997:64), are covered under the components of ‘rule’ and ‘division of labour’ in the AS.

The history aspect, which is much emphasized in the NLS, does not constitute one of the components in the AS. However, historicity is also considered as a key principle of Activity Theory, the implications of which “have been surprisingly little discussed, a notable exception being Sylvia Scribner’s (1985) impressive article on Vygotsky’s uses of history” (Engeström, 1999:25). As Vygotskian theory is often termed as “sociohistorical” or “cultural-historical” theory, Vygotsky holds that “because socially organized activities change in history, the human nature they produce is ... a changing category... (P)sychological study of human nature (thought and behaviour) must concern itself with the processes of formation of human nature ... need to search for specifically human behaviour in history rather than biology” (Scribner, 1985:122-123). Vygotsky attends to human mental development or cultural development taking place on two levels—the level of general world history and the level of individual history (ibid:125). Such arguments are also followed by the NLS theorization in the sense that the study of current literacy practices must involve the study of the history of literacy practices (see 2.3.3.2 above). As I am mainly concerned with the history on the individual level, I will integrate the historical dimension into the component of

‘subject’.

One aspect that appears to have been overlooked by researchers following the Vygotskian tradition is the emotional dimension of learning (Bazerman 2001, cited in Blackler & Kennedy, 2004). The importance of the emotional dimension in literacy practices has been discussed earlier (see section 2.3.5 above). The role of emotion and affect in learning process has also been widely explored in literature on learning and education (Cornu & Collins, 2004; Haynes, Ben-Avie, & Ensign, 2003; A. Jones & Issroff, 2005; O’Neil & Spielberger, 1979; Rubin, Katznelson, & Perpignan, 2005). It is sensible and possible to include the concept of ‘ruling passions’ from NLS while using the AT framework, as Blackler and Kennedy (2004) have demonstrated successfully by including an emotional dimension in their design and evaluation of a development programme for chief executives in public sector, which was informed by an Activity Theory approach to learning. I will again integrate ‘ruling passions’ into the ‘subject’ component.

Having now discussed the compatibility of the AT and NLS frameworks, I will further elaborate what I see as the advantages of using AS model in my study in the following part.

#### ***2.4.2.3 Advantages of the AS Model and its Suitability for My Study***

This complex model of AS (see figure 2.5 above) draws our attention to the social contexts in which the activity is situated, and the possible relationships, i.e. the interaction and contradiction, between each of the pairs of elements of the AS, which may play important roles in the process of activity, thus helping us understand what Vygotsky’s triangular model of mediated action (figure 2.4 above) is not able to account for. Blackler et. al. (1999, 1999a, 2000)’s interpretation of the AS model further clarifies the ways in which relationships can be analysed in an AS, as I will discuss in

the following part.

Blackler et. al. (1999a), in their organizational studies, elaborate on the ways in which the AS can help interpret relationships, arguing that this model of activity system is a way of “representing the relationships between personal knowledge and the cultural infrastructure of knowledge, and between individual actions and the broader pattern of activities of which they are a part” (p.6-7). Blackler et. al. (2000) view the AS model (see figure 2.5 above) as consisting of two triangles: the inner inverted triangle of ‘subject’, ‘object’ and ‘community’ that represents “relationships between individuals, their work colleagues, and the activity in which they are jointly engaged”, and the outer triangle of ‘mediating artefacts’, ‘rule’ and ‘division of labour’ that represents “factors that mediate these relationships” (Blackler, Crump, & McDonald, 1999a:7). They term the outer triangle as “the infrastructure of knowledge” (Blackler, Crump, & McDonald, 1999:208)—“material, mental, social and cultural resources for thought and action” (Blackler, Crump, & McDonald, 2000:281). They argue that the relations between each two components of the inner triangle are mediated by the component of the outer triangle that is between them. For instance: “the relations between individuals and the ‘object’ of their activity are mediated by concepts and technologies (mediating artefacts), the relationships between the community and the overall ‘object’ of its activity are mediated by its division of labour, the relations between individuals and the communities of which they are a part are mediated by rules and procedures” (Blackler, Crump, & McDonald, 2000:281). They also point out that “Activity Theory interprets practice as activity, explores the links between event and context ... Activity theory features the intimate relations between the factors that mediate activity and the activities themselves” (Blackler et al. 2000:278, 297). Based on their interpretation of the AS model, I would argue that one of the most important advantages of the AS model lies in



its power of exploring the relationships between the components during the process of activity. In my analysis, I will not restrict the discussion of relationships to the mediating relations that Blackler et. al. (2000:281) list above<sup>7</sup>. For example, while examining the relationship between the ‘subject’ and ‘community’, I will not only consider the ‘rule’ as a mediating factor, but also include ‘division of labour’ as a factor that may have effect on the relation between the ‘subject’ and ‘community’. A further point worth mentioning here is that the AS model visualizes the relationships, including the interactions and contradictions between the components through a triangular diagram as is shown in figure 2.5, which the NLS framework does not specify explicitly.

Another strength of AT is that the activity is analysed from two perspectives in the AS. As Engeström puts it,

Activity system as a unit of analysis calls for complementarity of the system view and the subject’s view. The analyst constructs the activity system as if looking at it from above. At the same time, the analyst must select a subject, a member (or better yet, multiple different members) of the local activity, through whose eyes and interpretations the activity is constructed. This dialectic between the systemic and subjective-partisan views brings the researcher into a dialogical relationship with the local activity under investigation. The study of an activity system becomes a collective, multivoiced construction of its past, present, and future zones of proximal development. ((Engeström, 1987)cited in Engeström and Miettinen 1999:10)

In other words, the AS model enables a researcher to attend to the particulars of a local activity from the ‘subject’ point of view—an insider’s view, as well as keep a comprehensive picture of the related factors around the activity—an outsider’s view from above the whole system. By choosing different participants in the same activity as the ‘subject’, the researcher can also gain insight from different insider perspectives about the same activity. In my analysis, I will first examine the process of reading activities from the ‘subject’ point of view to see how the ‘object’ is being constructed;

---

<sup>7</sup> I.e. “the relations between individuals and the ‘object’ of their activity are mediated by concepts and technologies (mediating artefacts), the relationships between the community and the overall ‘object’ of its activity are mediated by its division of labour, the relations between individuals and the communities of which they are a part are mediated by rules and procedures”.

and then look at the relationships between the components and between the past and current AS to see what contributes to the reading practices of the 'subject' from an outsider's point of view.

### **2.4.3 Summary**

In this section, I have introduced the AT and AS model, discussed the compatibility of the AT framework with the NLS framework, and illustrated the advantages of the AS model in my study of academic reading. In short, the AS model can incorporate all the key concepts of NLS, and the diagram of the AS model (figure 2.5 above) helps me visually keep track of the factors that mediate the reading practices in the particular situation that I am going to study.

There seem to be very few (only three as far as I have been able to determine) reported studies of reading using AT. Bomer (2003) studies the reading and writing workshops in a multi-age primary classroom in the USA. She used the Vygotskian framework to analyse the tools used in the classroom and found that even material objects without language in them can help children learn to do new things. The reading and writing workshops were viewed as an activity system, and her main focus was the nature and functions of the mediating tools. Johnson (2003) reports a study into the assessment of children's L1 literacy development in Bangladesh. Arguing that conventional assessment of reading and writing cannot fully capture children's potential of meaning making and communicating in reading and writing activities, Johnson and his colleagues proposed an alternative way of assessing reading, by putting students into a reading activity with fellow students and examining the students' use of tools (including non-linguistic tools), and the positioning of themselves in relation to other students and the task in the course of meaning making from the story that they were reading. Johnson concludes that the target of assessment should and can possibly be

broadened to include not only the outcomes, but also the action and artefact-mediated literacy learning process. Guikema (2004) applies AS to her study of intermediate-level learners of French. By examining learners' motives, choices, goals and strategies in reading and reflecting on foreign language texts, the study illustrates the influential role of the personal history, and the complexities of goal and strategy formation and modification, thus showing the nature of learner agency and awareness in literacy development. All three studies reviewed above are more concerned with the literacy learning process than the actual uses of literacy in real life situation; the first two studies (Bomer, 2003; D. Johnson, 2003) deal with the L1 literacy learning and only the third study (Guikema, 2004) is concerned with L2 literacy. The current study, instead, explores the literacy practices that are actually taking place in the subject's everyday life. By examining the interactions and contradictions between and within the constituent components of the AS, I am attempting to account for why the literacy practices are the way they are, which includes an examination of literacy development in both L1 and L2. Moreover, this study commits itself to the area of L2 literacy practices, which does not seem to have received much attention from researchers in NLS tradition. Therefore, through this study, I am applying the AT, which seems to yield promising new insights into literacy studies judging by the three studies reviewed above, together with the NLS framework, to the area of L2 academic reading, with a hope to reach a better understanding of Chinese students' academic reading practices in the settings under investigation.

## **2.5 Conclusion**

This chapter has endeavoured to build a case for adopting the NLS theorization of literacy over the 'autonomous model of literacy' that is more prevalent in the area of education and reading research over years, and has illustrated how NLS theories can be

applied to the study of academic reading. I have also argued for the possibility and necessity of combining the NLS and AT frameworks in order for more productive and constructive findings from the current study. Through a discussion of the main arguments of AT and the AS model developed by Engeström (Engeström, 1990, 1999), I have attempted to demonstrate the compatibility of the two theories, i.e. NLS and AT, and the advantages of combining the two of them for the potential new light that can be shed on the area of reading research.

In the next chapter, I will further elaborate the use of this theoretical framework in my data analysis, as well as explain the design and methodology of the current study.

Chapter Three Methodology .....	60
3.1 Introduction .....	60
3.2 Research Approach—Ontology and Epistemology .....	60
3.2.1 Ontological Position.....	60
3.2.2 Epistemological Position.....	63
3.3 Research Design .....	67
3.3.1 Pilot Study.....	68
3.3.2 Research Questions .....	71
3.3.3 The Subjects .....	73
3.3.4 Methods of Data Collection .....	77
3.3.4.1 Ethnographic Interviewing .....	79
3.3.4.2 Observation.....	80
3.3.4.3 Document Collection .....	82
3.3.5 Research Procedure .....	82
3.3.5.1 Preparation before the Main Study .....	82
3.3.5.2 Recruitment of the Subjects.....	83
3.3.5.3 Data Collection .....	85
3.3.5.4 Data Treatment and Analysis .....	86
3.4 Issues .....	88
3.5 Conclusion .....	90

## **Chapter Three Methodology**

### **3.1 Introduction**

In this chapter, I will explain the general research approach in terms of the ontological and epistemological positions that I am taking for the current study in relation to the theoretical framework that I have established in the previous chapter. I will then document the process of research design and conduct, including sampling, methods of data collection, and methods of data analysis.

### **3.2 Research Approach—Ontology and Epistemology**

#### **3.2.1 Ontological Position**

In my discussion of ontology, I will use Bhaskar's categorization of social reality (1978, 1998). This consists of three domains of reality—the real, the actual and the empirical. He argues that the world consists of structures and mechanisms, i.e. the domains of the real, which generate the phenomena that constitute the actual states and happenings of the world or in other words the sequence of events, termed by him as the domains of the actual, which in turn, may or may not be manifest to and empirically identified by men or women—as thinkers, perceivers, agents—i.e., in the domains of

the empirical. In other words, he holds that “the real”—structures and mechanisms<sup>1</sup>—exist independently of the actual patterns of events, and events may occur independently of experiences (Bhaskar, 1978 :13). For example, the existence of higher education institutions provides us with a range of possibilities of events and activities such as lectures, seminars, essay writing, academic reading, oral presentation, examinations, etc. However, the institutions, with structures within them and wider social structures, will not cease to exist even if the events are not taking place. Similarly, events, i.e. “the actual”, may occur whether people can perceive them or not. Thus, the events going on in the same seminar room are unlikely to be experienced in the same way by different people present there. Therefore, “[s]tructures and mechanisms ... are real and distinct from the patterns of events that they generate; just as events are real and distinct from the experiences in which they are apprehended. Mechanisms, events and experiences thus constitute three overlapping domains of reality, viz. the domains of the *real*, the *actual* and the *empirical*” (Bhaskar 1978:56, emphasis in the original).

For Bhaskar, “the real” constitutes a more fundamental domain of reality than “the actual”, and “the actual” more fundamental than “the empirical”. Human experience, i.e. “the empirical”, only represents the part of the reality that is perceived by human beings. And the understanding and explanation of “the empirical” can be achieved by reference to more fundamental domains of reality, i.e. the events from which such experience is extracted, and the structures and mechanisms that generate the events (Bhaskar 1978).

Bhaskar’s theory of ontology is also in harmony with the theoretical framework of the current study, which makes it possible for me to adopt his ontological position, as decisions about methodology are also inevitably guided by the theory of ontology that informs the study (Mason, 2002:179; Silverman, 2005:109). The theoretical

---

<sup>1</sup> In social sciences, or more specifically, in my study, the “real” refers to the social structures, i.e. the rules and conventions, relations, cultural tools, etc. of the research setting.

framework—a combined NLS and AT approach to academic literacy studies, that has been established in the preceding chapter—emphasizes the importance of examining the particular literacy events or activities in which people engage within the particular contexts in which the events or activities are taking place in any literacy studies. Under such a theoretical framework, the focus of my study from an ontological perspective is Chinese postgraduate students’ experiences and social practices of academic reading in a UK university, which involve the examination of the students’ past literacy experiences and practices, concrete reading events or activities that the students carry out as a form of the concrete realization of their reading practices, and the personal feelings and emotions, the social relations, and rules within the research setting that play a role in the students’ academic reading practices. In other words, to study practices and experiences, I consider three levels of the social reality to be relevant (see figure 3.1 below): firstly, I will concentrate on the person(s)—the Chinese postgraduate students that the current study concerns, examining their history of literacy learning and practices, feelings and emotions involved in their academic reading practices and values and meanings they attach to academic reading, corresponding to “the empirical” domain in Bhaskar’s terminology. Secondly, I will look at the academic reading events or activities in which the students engage, i.e. “the actual”. And thirdly, I will focus on the relations and interactions between the subjects, i.e. the Chinese postgraduate students in question, and the social institutional contexts, comprising the other members of the community, the rules and conventions of the community, mediating artefacts available, and so on—or in other words, the social structures and mechanisms—in order to see the possible factors that contribute to the shaping of the students’ academic reading practices and experiences.

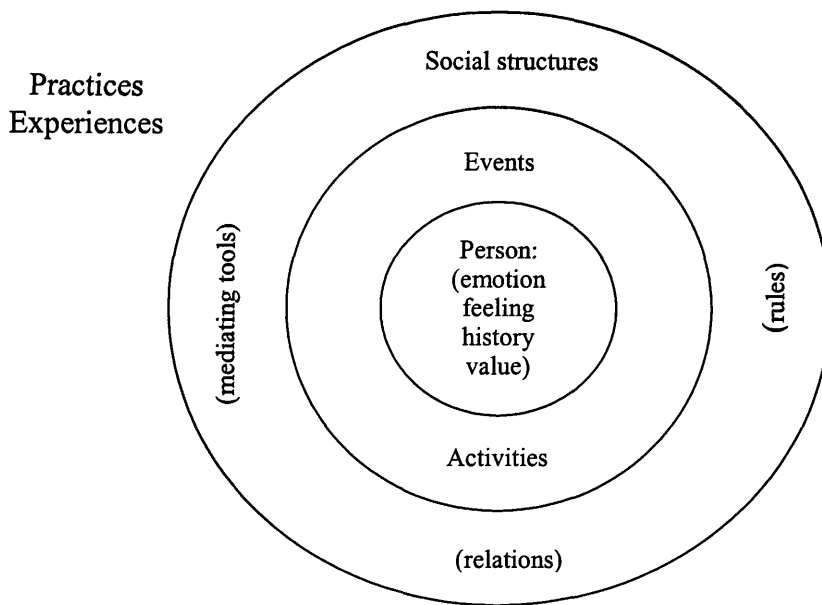

Figure 3.1

Ontology: three levels of social reality that will be investigated in the current study.

### 3.2.2 Epistemological Position

The preceding section on ontology has established the three domains or strata of reality that this research is concerned with, i.e. the Chinese postgraduate students' literacy experiences (the empirical), the literacy events they engaged in (the actual), and the social structures in which the experiences and events are embedded and conditioned (the real), with the latter domains or strata exceeding the former in terms of the ontological depth and providing possible explanations to the former (Bhaskar 1978, 1998). In this section on epistemology, what I need to establish is how these three domains of reality can be knowable, the answer to which in turn leads to the choice of research approach and methods of data collection.

In the stratum of 'the empirical', I am attempting to reveal and understand Chinese postgraduate students' academic reading experiences, as one of the major aims of this study. It seems that a powerful and effective way of gaining global knowledge about human experiences is via narrative. As many scholars and researchers have pointed out,



human experience can be tellingly revealed through accounts or stories told by the individual(s) in question (R. Atkinson, 2001; Bruner, 1985; Carter, 1993; Clandinin & Connelly, 1998; Mishler, 1986; Sarbin, 1986). For instance, Sarbin argues that “human beings think, perceive, imagine, and make moral choices according to narrative structures” (1986:8). Paley also holds that “none of us are to be found in sets of tasks or lists of attributes; we can be known only in the unfolding of our unique stories within the context of everyday events” (1990: xii, cited in Carter 1993:5). And as Gudmundsdottir puts it, “(the) narrative way of knowing ... is basic to the ways in which human beings understand the world and communicate that understanding to others” (Gudmundsdottir, 1991:207). Clandinin and Connelly express a similar view by saying that “stories are the closest we can come to experience as we and others tell of our experience. A story has a sense of being full, a sense of coming out of a personal and social history. ... Experience, in this view, is the stories people live. People live stories, and in telling of them reaffirm them, modify them, and create new ones” (1998:155).

Because of the strength of personal accounts and story telling mentioned above, narratives have been considered as an increasingly important means of inquiry in various areas, such as anthropology (Bateson, 1994; Geertz, 1995), psychology (Lieblich, Tuval-Mashiach, & Zilber, 1998; Polkinghorne, 1988; Riessman, 1993), history (Carr, 1986; White, 1981), education (Clandinin & Connelly, 1995; Clandinin & Connelly, 1996, , 1998, , 2000; Connelly & Clandinin, 1987, , 1988; Contreras E, 2000; Elbaz, 1983; Golombek, 1998), language education (Jill Sinclair Bell, 1997; J. S. Bell, 2002; Berman & Slobin, 1994; Johnstone, 1996; Kanno, 2000; Pavlenko, 2002; Pavlenko & Lantolf, 2000), organization studies (Czarniawska, 2001), and literacy (J. S. Bell, 1997a). In the area of academic reading, Mann (2000) has demonstrated the importance of exploring students’ “lived experience” (p.300) of academic reading

through constructing stories from interviews in understanding the meanings of reading to the informants as students and as human beings. In the current study of Chinese postgraduate students' academic reading practices, I have therefore also used narratives constructed on the basis of in-depth interviews to explore the subjects' past and current experiences of reading.

Events and activities, as the second stratum of reality, are usually studied through ethnography in both the NLS and AT tradition (Barton, 1994; Barton & Hamilton, 1998; Baynham, 2001; Blackler, Crump, & McDonald, 1999, 1999a, 2000; Blackler & Kennedy, 2004; Heath, 1983; Street, 1984, 1993). Ethnographic research is based on fieldwork, or in other words, the first-hand experience of a particular social or cultural setting mainly (though not exclusively) through participant observation (P. Atkinson, Coffey, Delamont, Lofland, & Lofland, 2001; Mason, 2002; Silverman, 2005). Atkinson et. al. (2001) point out that although "observation and participation remain the characteristic features of the ethnographic approach, [i]n many cases, fieldwork entails the use of other research methods too" such as interviewing, collecting textual and/or visual materials, collecting and analysing oral history and life history materials, narratives, etc. (p.4-5). Although neither observation nor participation is its central form of data collection, the current study can and should still be classified as taking an ethnographic approach because firstly, it is conducted in the setting with which the study is concerned; and secondly, the primary method of data collection, i.e. interview, belongs to the category of ethnographic interviewing "in which researchers have established respectful, on-going relationships with their interviewees, including enough rapport for there to be a genuine exchanged of views and enough time and openness ... for the interviewees to explore purposefully with the researcher the meanings they place on events in their worlds" (Heyl, 2001:369). Undoubtedly, it would have been desirable

to also watch the subjects in my study visit the library, browse the Internet for references, exchange email or discuss face to face with fellow students and tutors concerning reading, read texts, etc. in addition to ethnographic interviewing. However, considering the practical constraints such as that the students' timetables were so full, especially when the assignments deadlines approached, that they might only manage to visit the library during the break of lecture sessions or group meetings, or to search the references online and to read in the early hours of the day, it was not easy or even practically possible to arrange observations. And considering the characteristics of reading activities—i.e., much is going on in the reader's head—it may also be advisable to use more conventional method of reading research, the think-aloud protocol (Kamil, Pearson, Barr, & Mosenthal, 2000). However, the reason for not using observation and think-aloud protocol both lies in my reluctance of intruding the subjects' life and study too much. They all had a full timetable for their one-year masters' programmes, and observation and think-aloud methods of data collection will inevitably disturb their normal way of reading and take more of their time.

As Spradley (1979) has once pointed out, "the essential core of ethnography is this concern with the meaning of actions and events to the people we seek to understand" (Spradley, 1979:5). Thus, with my own experience as a master's student at the same university, living with and observing other students in the similar situation as the particular subjects of the current study, I felt it was not impossible and even quite sufficient to recapture the pictures of relevant events and activities in the subjects' lives through ethnographic interviews together with the help of other materials such as notes the students took while reading, written requirements for reading and writing, observation of lecture sessions, and so on.

In the third stratum of reality, the social structures as the governing mechanisms of

activities, as Bhaskar (1998) points out, “exist only in virtue of the activities they govern and cannot be empirically identified independently of them” (Bhaskar, 1998 :38). To study the social structures, Bhaskar further argues that we need “a system of concepts designating the ‘point of contact’ between the human agency and social structures” (ibid:40). Such a mediating system is conceptualized in his terms as “that of the *positions* (places, functions, rules, tasks, duties, rights, etc.) occupied (filled, assumed, enacted, etc.) by individuals, and of the *practices* (activities, etc.) in which, in virtue of their occupancy of these positions (and *vice versa*), they engage” (ibid:40-41, emphasis in the original). Bhaskar’s idea of such a mediating system, which has been developed from Marx’s works (K. Marx, 1974, , 1975), echoes exactly the conceptualization of the AS model, which stresses that the activities (the ‘subject’s’ working on the ‘object’) are conditioned and mediated by the other components (the ‘mediating artefacts’, ‘community’, ‘rule’, ‘division of labour’) in the system; and at the same time the social conditions and structures are either reproduced (revealed as they are) or transformed (modified to some extent) as a result of the activities (Engeström, 1987, 1999). Such a system helps us to investigate social relations, which in turn help us understand the social structures in which the social explanations for activities lie, as social structures “must always include or tacitly presuppose ... some or other social relation” (Bhaskar 1998:41). Therefore, I will explore the relationships between the components of the AS in seeking the social explanations for the academic reading activities that the Chinese postgraduate students engaged with in my study, and in so doing, reveal the nature of the social structures that mediated and conditioned the activities.

### 3.3 Research Design

Having explained the ontological and epistemological stances underlying the study,

in this section I will lay out the research questions that the current study sought to answer, the sampling of the subjects, the methods of data collection, the design of the instruments for data collection, the procedure of the data collection, and finally the methods of data analysis. Before doing this, it is also necessary to briefly mention the pilot study that was carried out from March to July 2003, which laid the foundation for many of the decisions that I made regarding the design and conduct of the main study.

### **3.3.1 Pilot Study**

The main purpose of the pilot study was to get a ‘feel’ of the field of academic literacy practices, with special concerns on reading, in the research site in question. In so doing, in other words, I was trying to identify a possible focus of the proposed main study, and possible research methods for it.

I chose to focus on a group of Chinese postgraduate students studying at Lancaster University as the subjects for my research, because as an English language teacher at a Chinese university, I felt I had the relevant background knowledge to enable me to better understand Chinese students than students from other countries. Also, I chose to focus on postgraduates rather than undergraduates because the former constitute the major proportion of Chinese students studying at Lancaster University (both in terms of the actual number and the percentage in relation to the whole student population according to the statistics from Student Registry office of Lancaster University). Such students all got their first degree in China before coming to the UK. Thus, I felt that their experience of academic reading in Chinese, and English language learning at Chinese universities may enable me to find out whether and to what extent these factors matter in their academic reading in English. The subjects were selected in consultation with other postgraduate students in the Department of Linguistics and English Language (LAEL), who also provided me with a number of contacts whose

characteristics match my subject profile. I had intended to include master students from management, social sciences, and sciences programmes. However, given the small number of Chinese students doing sciences programmes, and the limited time for the pilot<sup>2</sup>, I was not able to find a science student for the pilot study. The details for the five subjects are as shown in Table. 3.1 below:

Subject	Gender	First degree	No. of years of work experience	Area of work experience	Lancaster degree programme
Y	F	Marketing	2	Marketing in tourism	MA. in Tourism and Leisure
F	F	International Business	6	Business	MSc in Management
Q	M	English	5	Language teaching	MSc in Management
J	F	Accounting	0	N/A	PhD in Accounting
D	F	Accounting	1	Stocks and securities	MSc in Finance

Table 3.1 Details of pilot study subjects

I started my pilot study research with an initial focus on the difficulties that my subjects—Chinese postgraduate students at Lancaster University—might experience in reading while they studied at a UK university, and factors that contributed to the formation of those difficulties. However, after the first interview with one of the subjects, I thought it would be better not to presuppose the existence of difficulty, or at least not to put too much emphasis on the difficulties in the first place, since to do so would be to adopt a ‘deficit-oriented’ perspective. Thus, I shifted the focus to investigating reading practices in general, trying to explore how and why the students’ reading practices had developed into their current forms.

There were two stages in the pilot study: first, an initial set of interviews aimed to eliciting more general information, e.g. family background, learning experience of Chinese and English, experiences of reading in Chinese and English before and after

<sup>2</sup> Due to the fact that the researcher was approaching the end of her pregnancy.

coming to the UK, and differences between their reading experiences in China and UK (see appendix 25 for detailed information), and second, a further round of interviews, comprising more concrete and detailed questions about the subjects' reading experiences in the UK in contrast to in China (see appendix 26). The interviews were all conducted in Chinese, audio recorded, and transcribed into Chinese. The transcriptions that were quoted in the analysis of the pilot study were translated verbatim into English. The subjects' reading experiences were organized into narratives; the subjects' academic reading practices were then analyzed in the activity system model: the features of the activity system of a Chinese university and that of a UK university had been compared, and the internal conflicts of the activity system had been explored to reveal the development of the subjects' reading practices. The pilot interviews formed the basis on which the interview plans for the main study were formulated.

Judging by the analysis of the pilot data that has been done by drawing upon theories of NLS and AT, it seemed more practical and productive to narrow the focus of my study down to one type of literacy practice—reading for the purpose of writing assignments. The reasons for this decision were: firstly, as was shown in the pilot data, this type of practice was considered as the most significant among their reading tasks according to most subjects; secondly, it entails some key elements of other types of reading practices (e.g. reading before attending a lecture/seminar, reading for presentation); thirdly, as students usually have more than one occasion when they need to write an assignment during the course of most masters' programmes (in contrast to the writing of the dissertation toward the end of their study), I felt it was possible for me to see the development of the subjects' reading practices in the activity system in question.

The pilot analysis also showed that in order to apply the Activity Theory more

effectively, it was essential to define appropriately the activity system in which I would study the subjects' reading practices. It also appeared reasonable to focus on two masters' programmes in two different departments, and look at two subjects from each programme (three or four subjects were selected in each programme in order to make sure there were two subjects remaining in the study). In so doing, I was attempting to investigate Chinese students' reading practices for the purpose of writing assignments in two activity systems (i.e. two masters' programmes) from two subjects' perspectives. Potential advantages of doing this were felt to be: firstly, focusing on fewer activity systems might allow me to make fuller exploration of each activity system in question, instead of touching on a lot of systems only superficially, and similarly, focusing on two subjects in each activity system was felt to allow more detailed study of each individual; secondly, looking at two systems instead of one might enable me to get a better picture of the ways in which students' reading practices may be similar or different in different activity systems; thirdly, by choosing two masters' programmes in two departments instead of in the same departments, it might be more likely to reveal differences between activity systems at the departmental level; finally, having (at least) two subjects from each AS allowed me to examine the reading practices from (at least) two different perspectives.

### **3.3.2 Research Questions**

The overall purpose of the study was to attempt to produce a comprehensive picture of Chinese postgraduate students' academic reading experiences in a UK higher education situation (with Lancaster University as an exemplar), unfolding the details of students' day to day practice of academic reading and their experiences of reading while doing assignments, the implicit rules of the current activity system and the implicit expectations from tutors regarding students' reading and writing, and the overt and



hidden conflicts between the students and other components of the activity system. As a result of this study, I have also had it in mind to draw pedagogical implications for L2 literacy teaching and academic subject teaching to Chinese students in English-speaking countries, and to examine the appropriateness and potential of the conceptual tools—NLS and AT—in the area of L2 reading research and teaching.

The main research questions (RQ) my study involved were as follows:

1. What were the main reading practices of the subjects before they came to the UK? This question was aimed to reveal the subjects' literacy history prior to their study in the UK, which is an indispensable element contributing to the understanding of their current literacy practices in the UK university setting.
2. What aspects in the context (in terms of the activity system model) have played what role in the shaping of the subjects' reading practices prior to their arrival in the UK?

The second RQ intended to account for the subjects' literacy history from the perspective of Activity Theory. Together with the first RQ, these two questions attempted to form the basis on which the comparison between the past and the current activity systems could be made in order to identify possible roles of the subjects' literacy history in their literacy experiences in the UK.

3. What are the main kinds of academic reading practices which the students experience in a UK university setting?

This question was designed to explore the subjects' academic reading practices in general in their current settings with a view to constructing the activity system of the two masters' programmes.

4. What are the features of the activity system of a master's programme in a UK university in comparison with and in contrast to the activity system that the subjects

used to belong to in China?

RQ 4 was aimed to identify the characteristics of each of the components in the activity systems in which the subjects were currently participating, and to make comparison and contrast with the activity systems that the subjects used to belong to before they came to the UK. The answer to this RQ was essential for answering RQ 6 below.

5. What literacy experiences did the subjects actually have while reading for writing assignments within the context of their current activity systems?

This RQ was designed to reveal a detailed picture of the subjects' academic reading experiences while writing assignments, including aspects such as how and why they chose to write a certain topic, to read certain materials and to use them in certain ways into their writing; how they felt about their decisions and performances; how they viewed the importance of academic studies in their life and future, etc.

6. What factors appear to have led to the subjects having such experiences?

This last RQ was aimed to explore the contributing influences that played a role in the subjects' academic reading experiences, by taking into account the answers to the first four RQs, and by studying the interactions and interrelationships between the components of the activity systems of the masters' programmes.

In what follows, thus, the details of the research methodology that was used in order to obtain data that might answer these questions are described.

### **3.3.3 The Subjects<sup>3</sup>**

As was mentioned at the end of 3.3.1 above, on the basis of the pilot study, it appeared theoretically reasonable and practically feasible to focus on two masters' programmes in the main study instead of one programme or more than two programmes.

---

<sup>3</sup> To make distinction between the "subject" as the student participant in my study, and the "subject" as the component of the activity system, from this point onwards, I will use 'subject' (in inverted commas) to refer to the component of AS. This also applies to all other components of the AS.

Due to the qualitative nature of the main study, in order to achieve the level of detail and depth of the analysis needed, it was not felt advisable to try to focus on too many programmes; whereas on the other hand, to study only one programme was felt to run the risk of producing too narrow a picture.

As the main purpose of the main study was to throw light on the academic reading experiences of Chinese postgraduate students in UK university setting, in order to increase understanding by subject tutors and EAP tutors, it was felt to be sensible to study those programmes which attracted a relatively large number of Chinese students. The MSc. in Management programme was selected as one of the masters' programmes because it had more Chinese students than any other masters' programmes in Lancaster University. Moreover, this programme is a Management school programme, which does not belong to any one department, but is team taught by staff from different departments in the school. In other words, this programme touches upon all areas in Management by offering students one module in each relevant area of Management. As a result, students in the MSc. in Management programme study at least one module, whose reading and writing requirements may be similar to the students from the department which offers that particular module; and through the study of the students in MSc. in Management programme, one may get some rough idea of the reading and writing requirements for other masters' programmes in the Management school. That was also the reason why I did not choose other programmes in Management School that outnumbered the MA. in Education programme in terms of Chinese students. I chose the MA. in Education programme because firstly, it had the largest group of Chinese students outside the Management School; secondly, I found that it could form a better contrast to the MSc. in Management programme compared to other programmes in Management School in terms of the reading and writing requirements. The masters' programmes in the "hard"

sciences were not considered in this study because of the relatively small number of Chinese students recruited, which on the one hand, may make it difficult to find suitable subjects for my purpose, and on the other, may make the study less beneficial and informative because the programmes that were studied did not involve many Chinese students.

In each master's programme, I focused on the reading for writing assignments of two modules which were taught in the first term: modules "Teaching, Learning and Assessment", and "Introduction to Educational Research" in MA. in Education programme were chosen because they were the only two core modules in the first term besides the study skills core module. For MSc. in Management programme, modules "Learning to Manage" and "Economics for Managers" were chosen considering the contrasting nature of the reading and writing requirements: the former mainly involved reading of management theories and their application in the daily practice in the management world; the latter involved reading of mathematical analysis, statistical interpretations, mathematical models, and the like.

As was mentioned at the beginning of section 3.3.1 above, Chinese students doing masters programmes in the UK were the primary subjects. I decided to focus on the postgraduate level instead of the undergraduate level because the proportion of Chinese students in the whole student population was higher at the postgraduate level than the undergraduate level. In addition, I only chose those students who had obtained their first degree in China before they came to the UK, so that their experiences of academic reading in Chinese (and English in some cases) and English language learning at Chinese universities may enable me to find out whether and to what extent these factors matter in their academic reading in English in the UK higher education system. Another reason for focusing on the master's level is that my own experience as a master's

student in the research setting has allowed me the opportunity to position myself as an insider as well as an outsider in my research. My experience may also help establish trust and good rapport between the researcher and the subjects, which is essential for the kind of in-depth and continuous ethnographic interviewing that this research is applying (J. M. Johnson, 2001). However, the way in which this research was designed did not seem able to show the extent to which the difference between the reading requirements at the undergraduate and postgraduate levels might affect the Chinese students' academic reading practices in the UK. I am not denying that the difference in the reading requirements of the undergraduate and postgraduate studies may well have a role in the subjects' experiences of academic reading in the UK. To find out that, I need to conduct a research similar to the current one in order to get a picture of the students' academic reading practices in the Chinese postgraduate education. As my main focus is the subjects' reading practices in relation to the UK academic discourse community and due to the limited space of this thesis, I felt it not practical to add a dimension of the undergraduate versus postgraduate comparison.

I also included some subject tutors who were involved in designing and/or teaching the modules mentioned earlier, as well as tutors (conveners) for academic support course as another data source in order to get first hand information on reading and writing requirements for the modules that they taught, help that was or might be available from the academic staff to the students concerning reading, and the feedback on students' assignments. In this way, I may also be able to cross-check some students' data.

The following tables summarize basic information about the main study subjects (\*indicates the cases that are reported in the thesis):

Name of the master's programme	Name of the interviewee	Gender	First degree
MA. in Education	E1*	F	BA in English Language and Literature
	E2*	F	BA in History
	E3	F	BA in English Language and Literature
MSc. in Management	M1*	M	BA in English for Technology
	M2*	F	BA in English Language and Literature
	M3	F	BA in Chinese Literature

Table 3.2: student interviewees

Name of the master's programme	Interviewee	Responsibility
MA. in Education	Tutor 1	Lecturer of the 'Teaching, Learning and Assessment' module
	Tutor 2	Lecturer of the 'Teaching, Learning and Assessment' module
	Tutor 3	Convener of the 'Introduction to Educational Research' module
	Tutor 4	Lecturer of the 'Introduction to Educational Research' module
	Tutor 5	Convener of the 'Study Skills Core Module'
MSc in Management	Tutor 6	Lecturer of the 'Learning to Manage' module
	Tutor 7	Lecturer of the 'Economics for Managers' module
	Tutor 8	Lecturer of the 'Economics for Managers' module
	Tutor 9	Seminar leader of the 'Learning to Manage' module
	Tutor 10	Tutor of academic support course

Table 3.3: tutor interviewees

### 3.3.4 Methods of Data Collection

As has been pointed out in section 3.2 above, my study involved an ethnographic approach and the primary method of data collection was ethnographic interviewing—a series of in-depth interviews conducted on the spot of the research setting over a period of time, in and through which the interviewer and interviewees develop a relationship that enables them to explore meanings the interviewees place on events and activities (Heyl 2001). The interviews in this study were semi-structured (Mason, 2002;

Oppenheim, 1992), where I planned a number of topics to cover but also allowed room for developing unexpected themes during the course of interviewing. In addition to interviews, observation and document collection were also used to collect information complementary to the interview data. In this section, I will explain why and how the three methods have been used in the current study. Table 3.4 below shows the relationship between the research questions and the methods of data collection:

Research questions:	Methods:
1. What were the main reading practices of the subjects before they came to the UK? 2. What aspects in the context (in terms of the activity system model) have played what role in the shaping of the subjects' reading practices prior to their arrival in the UK?	Interview with students
3. What are the main kinds of academic reading practices which the students experience in a UK university setting?	Interview with students; observation of lectures; collection of students' reading materials, reading notes, etc.
4. What are the features of the activity system of a master's programme in a UK university in comparison with and in contrast to the activity system that the subjects used to belong to in China?	Interview with students; interview with tutors; observation of lectures; collection of documents such as programme/course handbook, lecture handouts, reading lists, writing task sheets, etc.
5. What literacy experiences did the subjects actually have while reading for writing assignments within the context of their current activity systems?	Interview with students; collection of students' reading materials, reading notes, writings, etc.
6. What factors appear to have led to the subjects having such experiences?	Interview with students; interview with tutors; collection of tutors' feedback sheets and written comments within the students' writings

Table 3.4: research questions and corresponding methods of data collection

### **3.3.4.1 Ethnographic Interviewing**

Ethnographic interviewing was applied in this study to explore firstly the subjects' past experience of learning their mother tongue and English, and of learning to read in these two languages, and their past literacy practices. The reason for covering this aspect in the interview is due to the importance that the NLS and AT frameworks attach to people's literacy and education history in our understanding of literacy. As was argued in section 3.2.2 above, personal accounts or narratives are a powerful means of studying experiences. And the open-ended, in-depth ethnographic interviewing appears better at soliciting the kind of narratives from the subjects than methods such as questionnaire. This interview was chronologically structured, intending to cover the subjects' learning of and reading in both mother tongue and English at four stages—pre-schooling stage, primary school stage, secondary school stage, and tertiary education stage, with questions tapping on their literacy practices both within and without the educational settings at various stages (see appendix 1 for the detailed interview plan and the relation between the RQs and the interview questions).

Secondly, for reasons outlined in section 3.2.2 above, ethnographic interviewing was used to help the subjects' recall and retell their current academic reading practices and experiences in the research setting, particularly those related to the writing of assignments. A series of interviews were designed to be conducted at different stages during the subjects' stay at Lancaster University: firstly at the beginning of the first term in order to find out the subjects' general reading practices and academic reading practices after their arrival in the UK; secondly during the first term while the students were preparing and writing their assignments, to see their academic reading practices and experiences for the purpose of writing particular assignments; thirdly after they finished writing the assignments, to find out their self evaluation of their reading and



writing; and finally after they got the tutors' feedback of their writings, to see their understanding of the feedback, whether and to what extent they agreed with their tutors' comments, lessons learned from the reading for and writing of the assignments, how they will approach other assignments and the final dissertation in the future and so on (see appendices 1, 2 and 3 for the relation between the RQs and the interview questions and the corresponding interview plans).

Thirdly, ethnographic interviewing was also used to explore the reading and writing requirements from the tutors' perspective and their comments on students' writing. The first set of interviews intended to explore from the tutors' point of view, the reading and writing requirements for the modules that they taught, their expectations of students' reading and writing, the choice of reading materials, the function of lectures and reading materials and the relationship between the two, and channels of student-tutor communication to help students with their reading and writing. Another set of interviews was addressed to tutors of academic support courses in order to find out what type of support concerning academic reading and writing was available from such courses. A third set of interviews was designed to explore tutors' comments on students' writing and reading after they finished marking the assignments (see appendices 4 and 5 for interview plans for subject tutors, and appendix 6 for the interview plan for the tutors of the study skills courses, and the relation between the RQs and the interview questions).

### **3.3.4.2 Observation**

Observation of lecture sessions and of students' reading activities was carried out because the rich picture of observations might provide important background information for the design and interpretation of the interview data. Observation was used in two ways in the current study. Firstly, it was used as a supplementary way, in

addition to tutor interviews, of finding out how pre-reading materials were used in relation to the lecture sessions. Therefore, the focus of the observation was on the settings of the classroom, the seating arrangement, the lecturers' presentation formats, visual aids, occasions when the lecturers mentioned or used the pre-reading materials, occasions when the lecturers or students asked questions, classroom activities (besides lecturing) where the pre-readings or textbooks played a role, and so on. In this way, I felt I would be able to better understand the lecturers during the interviews regarding the relations between the readings and lectures as they could use the lecture sessions that I observed to illustrate their points. Field notes were taken as the record of the observations. As the emphasis was not on the classroom interactions between the tutors and students, I did not make audio recording during the observations.

Secondly, and less formally, systematically, and overtly, from time to time, I observed other Chinese students (both undergraduate and postgraduate) known to me, whom I happened to have a chance to see or stay with while reading, visiting the library, searching references online, making notes, discussing readings with others, etc. to get an idea of what kind of activities they usually engaged themselves in. Although I did not directly observe the subjects involved in the study due to my reluctance of taking up too much of the subjects' precious time and of disturbing their normal life and study, and although each student may have his/her unique characteristics in reading practices, it was still felt worthwhile to observe other Chinese students in this way and use the observations and my own experience as a postgraduate student to guide the interviews in order to reconstruct the subjects' the reading activities. It was reasoned that the subjects were also likely to engage in the kind of reading activities that many other students find themselves doing.

### **3.3.4.3 Document Collection**

Certain written materials were collected during the course of this study as a supplementary data source, in order to serve various purposes: for instance, students' writings, tutors' feedback and comments can be used to help formulate interview questions and elicit answers; notes and marks made by the students while reading can help illustrate interview data with concrete examples; documents such as course handbook, assignment guidelines, and so on, provided extra information concerning the modules. The documents collected included module handbooks outlining the course aim, content, assessment, reading and writing requirements; reading lists; assignment guidelines; lecture handouts; copies of reading materials in which the students had marked and made notes; notes taken by the students while reading (both for pre-reading tasks and for the writing tasks of the two modules under investigation); students writings for the two assignments in question; tutors' comments and feedback on student writings; and so on.

### **3.3.5 Research Procedure**

In this section, I will document the whole process of the planning, data collection, and data analysis of the research.

#### **3.3.5.1 Preparation before the Main Study**

A pilot study was carried out from March to July 2003, by interviewing five Chinese postgraduate students studying at Lancaster University twice regarding their literacy experiences and practices both before and after their arrival in the UK, through which the focus of the main study has been narrowed down to the academic reading practices and experiences for the purpose of writing academic assignments and the scope of sampling has been clarified to be two (to three) Chinese students in each of the two

masters' programmes chosen as the two activity systems (see section 3.3.1, 3.3.2 and 3.3.3 above for details). The two masters' programmes chosen for the main study were identified by means of examining the statistics of the distribution of Chinese students population across different departments in Lancaster University over the past four years (from academic year 2001-2002 till 2004-2005)—the MSc. in Management hosting the largest group of Chinese students in all four academic years, and MA. in Education hosting the largest group of Chinese students outside the Management School over the last two academic years. Although programmes in Management School usually outnumber programmes in other faculties and departments, in order to form potentially better comparisons and contrasts in the two activity systems this study concerned with, it seems more sensible to choose one programme within the Management School and the other without (also see 3.3.3 above for reasons for the choice of the programmes).

### **3.3.5.2 Recruitment of the Subjects**

The main study was carried out during the academic year 2004-2005. After deciding on the two masters' programmes as the two activity systems for the study, I used my social networks in recruiting subjects (Arksey & Knight, 1999; Biernacki & Waldorf, 1981; Weiss, 1995), i.e. seeking help among friends and colleagues to introduce their friends in these two programmes who met the criteria of the subject in my study and who would like to take part in it, with a hope that friends or friends of friends may be more cooperative during the course of research which may more likely ensure a smooth progress of the research.

Ideally, I would have liked to be able to recruit subjects who had studied a number of different specialisms for their undergraduate degrees, because as the pilot study showed, what the subjects specialized in for their undergraduate studies did play some role in their reading in the UK university setting in question. With subjects from various

undergraduate specialism backgrounds, it may be possible to see to what extent such background influenced students reading. However, it turned out to be quite difficult to do so, as the subjects that I first recruited in the MSc. in Management programme all happened to have done their first degree in English language in China. I then, managed to get help from their programme director to circulate an email among the whole group of Chinese students in this programme asking them about their first degree, hoping to recruit subjects with other undergraduate subject background. The reply rate was very low (about 5-8%), and among those few who replied, most of them studied English language for their first degree. According to the subjects recruited (to the best of their knowledge), the majority of their Chinese course mates also had a first degree in English Language, with the exception of a couple of students with science, engineering, and other background. Fortunately, one of the Chinese students who replied to my email had studied Chinese Language and Literature who also agreed to take part in my research. The situation in the MA in Education programme was simpler: there were twelve Chinese students in that programme and only one of them did a first degree in history (who agreed to attend the study) and the rest all hold a BA degree in English Language. In the end, I managed to recruit one subject with a BA in History Education, one with a BA in Chinese Language and Literature, one with a BA in English for Computer Science, and three with BA in English Language and Literature (see the summary of the subjects in Table 3.2 in section 3.3.3 above). Half of the subjects had a first degree in English Language and Literature, reflecting the fact that the majority of the Chinese students in both programmes came from such a background. And I have also tried to ensure some variety in terms of the subjects' undergraduate specialisms.

As for the tutor interviewees, I contacted the tutors (the module conveners or coordinators in the cases of team taught modules) of the relevant courses that this study

concerned with (also including academic support course in both programmes) via email, asking for an interview and possibility of observing one of the lecture sessions. It took up to a few weeks time to get reply back from various tutors. Through the introduction of the conveners/coordinators, I contacted the other tutors in those modules asking for permission for interviews and observations. By the time I got replies from all tutors, it was sometimes impossible to observe their lectures because some of them had already finished teaching their share of the modules. When a module involved too many tutors (e.g. up to 7 tutors), I waited till the students got their assignment marks back and then contacted their markers, asking for interviews about their comments and the part of teaching they did for the module. Most of the tutors were helpful and cooperative, but there were also a couple of tutors who refused to be interviewed even after I tried to persuade them several times, in which case I had to give up.

### **3.3.5.3 Data Collection**

For each student subject, I interviewed them firstly about their past literacy experiences and practices (for some subjects, this interview was scheduled during the Christmas holiday due to their tight timetable in the first term); secondly about their general literacy practices and academic literacy practices in the current situation; thirdly about their experiences of reading for the purposes of writing their first assignment; fourthly about their self-perception of their reading and writing of the first assignment; fifthly about the tutors' feedback on their writings, the lessons they learned from their first experience, and their potential future practices. The third, fourth and fifth interviews were repeated for the second assignments this study concerned with. During the interviews, I normally rephrase or paraphrase the interviewees' answers from time to time in order to ensure the accuracy of my understanding of the answers. As already explained (see 3.3.4.1 above), I have prepared outlines of each interview, but during the

interviews I also allowed the interviewees to talk about things that they felt worth mentioning.

For tutor interviewees, firstly I interviewed them about the way they taught particular modules that this research concerned with, the reading and writing requirements for the modules, relationships between the readings and the lectures, their expectations of students' reading and writing, and academic support available to the students; and secondly after they marked the students' writings, about the general impression of all the writings they had marked, and the particular subjects' performances.

I observed one lecture session of each of the four modules I focused on (see 3.3.3 above for details of the courses, and 3.3.4.2 above for details of the observation). Documents of the kind described above (see section 3.3.4.3 above) that may be relevant to the research were collected during the course of interviews and observations.

It may be more desirable to extend the period of data collection till the end of the subjects' masters' studies, as ethnographic research usually features prolonged period of contact in the research setting (P. Atkinson, Coffey, Delamont, Lofland, & Lofland, 2001; Mason, 2002). I decided not to do this because firstly, there was only limited time available to finish this research; and secondly, the subjects' answers in interviews following their first and second assignments showed that they would most likely keep the majority of the reading practices they had undertaken earlier when they did later assignments.

#### **3.3.5.4 Data Treatment and Analysis**

All interviews have been audio recorded and transcribed (mostly word by word) into the language in which they were conducted, i.e. interviews conducted in Chinese were transcribed into Chinese and those in English into English. Chinese interview

transcriptions were translated into English only when they were quoted into the thesis. Field notes of observations were read through carefully, and summaries about observations were written shortly after each observation session. The results of observations also formed part of the following interviews with students and/or tutors in order to clarify or confirm what could not be observed.

All transcriptions were reviewed for a second time by listening to the recordings, which was done by the researcher herself in order to keep the data as confidential as possible when the subjects still remained in the research setting. While interpreting the transcriptions, I sought verifications from the subjects concerning my understanding of the interview data via face to face talk (interviews at a later stage), telephone conversation, or email, which is sometimes called 'respondent debriefings' (Singleton & Straits, 2001).

Data about the subjects' past experiences and practices were arranged into narratives which highlighted the unique features of each subject's experiences and practices. The subjects' educational experiences were then analysed within the AS model to reveal the characteristics of the Chinese education system and the possible effects on the subjects' reading experiences and practices. Data about the subjects' current general literacy practices, and their current reading and writing requirements were treated in a similar way mentioned above, and as a result, the two masters' programmes were analysed and constructed as two activity systems. Interview data about the subjects' experiences of reading for the purposes of writing assignments were first examined with a view to revealing the process of the construction of the 'object' of the reading activities in which the subjects' were engaging while writing their assignments; and secondly examined in terms of the relationships between each pair of the components in the activity system model with a view to exploring the contributing



factors of the subjects' current academic reading experiences and practices. To protect the subjects' identities, and for ease of reference, in what follows, the two MA. in Education subjects will be referred to as E1 and E2, and the two MSc. in Management ones as M1 and M2. Also, the tutors mentioned in the thesis were all anonymous.

### **3.4 Issues**

As for all research reports, issues like reliability and validity constitute an indispensable part of the discussion. As is argued by various researchers and scholars, qualitative research should not be evaluated by the same criteria of validity and reliability developed for quantitative research (Altheide & Johnson, 1998; Mason, 2002; Silverman, 2005). Mason suggests two ways of demonstrating the validity of qualitative research, i.e. to show the validity of data generation methods and the validity of interpretation (2002:189). By validity of data generation methods, she means that data sources and generation methods can potentially answer the questions the researcher is attempting to answer through the research (Mason 2002), which has been discussed in sections 3.2.1 and 3.2.2 above in this chapter. The validity of interpretation depends on the reflexive accounting for the data interpretation process (Altheide and Johnson 1998; Mason 2002), which means the researcher should be able and prepared to show in what context and setting, from what perspective, with whose voice, in what representational and rhetorical forms, and to what audience the interpretation is made. This has been briefly outlined in sections 3.3.5.3 and 3.3.5.4 above in this chapter, and will be spelt out in more detail in the following data chapters. Reliability can be demonstrated, according to Mason (2002), by ensuring the audience that the “data generation and analysis have not only been appropriate to the research questions, but also thorough, careful, honest and accurate (as distinct from true or correct—terms which many qualitative researchers would, of course, wish to reject)” (p.188). This, again, has been

discussed under sections 3.2.1, 3.2.2, 3.3.5.3, and 3.3.5.4 above.

The researcher's role and position is another issue that I want to emphasize here as it determines, to a great extent, the process and the result of ethnographic research (D. Goodwin, Pope, Mort, & Smith, 2003; Punch, 1994; Rowling, 1999; Walmsley, 2004). Just as Punch points out that "where you stand will doubtless help to determine not only what you will research but also how you will research it" (1994:94), my decision on the research topic, focus, theoretical approach, subjects, and so on, was closely related to my experiences as a postgraduate student in the research setting, and as an English language teacher in a Chinese university. Such experiences helped me more easily establish rapport with the subjects and understand their situations; but on the other hand, also brought the danger of being engaged too deeply in and unable to step back from the field (D. Goodwin, Pope, Mort, & Smith, 2003; Hammersley & Atkinson, 1995). This also brought the issue of how intimate or detached the researcher should be in the relationship with the subjects: for instance, when the subjects encountered problems that I might help them with, should I remain as an 'observer', or should I interfere and act as a friend, a helper, or a fellow student with more experience in the academic setting? Rowling (1999) terms this type of tension as the "clash between the 'researcher I' and the 'counsellor I'" (p.172). Goodwin et al. (2003) point out that "ethical conduct is not fixed, but is personally, socially, and contextually constructed" (p.569). Rowling (1999) also argues that "interfering" with the participants does not always have a negative effect on the research, as her study demonstrated that such "interfering" proved to produce positive and profound outcome. Therefore, from an ethical point of view, I would argue that in return for the cooperation and help the subjects offered me in my research, I should always try to provide them with as much advice, support, comfort and encouragement as possible. That was what I actually did during the course of my

research, and thus developed a friendly relationship with the subjects. At the same time, I feel confident that my involvement in this way was not such that the basic veridicality of my apprehension of the situation in focus was impaired.

### **3.5 Conclusion**

In this chapter, I have attempted to explain the ontology and epistemology that guide the research design, and have documented the whole process of research design, conduct and methods of data collection (or “generation” in Mason’s (2002) term) and data analysis. There has also been brief discussion of issues concerning validity, reliability and research ethics within various sections in this chapter. More detailed account of the methods of data analysis will be presented in the data chapters following this chapter.

Chapter Four: Stories of the Four Chinese Students and the Past Activity System.....	91
4.1 Introduction .....	91
4.2 A Historical Account of E1's Experiences of Learning and Reading in Two Languages .....	92
4.2.1 A Book Lover by Nature—Reading in Chinese .....	93
4.2.2 An Unsatisfied Learner of Chinese at School.....	95
4.2.3 A Top Student in a Foreign Languages Middle School .....	96
4.2.4 A 'Careful Investor'—Literacy Practices at University in China.....	98
4.2.5 Summary .....	101
4.3 A Historical Account of E2's Experiences of Learning and Reading in Two Languages .....	102
4.3.1 A Reluctant Reader.....	102
4.3.2 An Average Student Who Loved History .....	104
4.3.3 Learning of Two Languages.....	105
4.3.3.1 Learning Chinese .....	105
4.3.3.2 Learning English.....	106
4.3.4 Literacy Practices at University .....	107
4.3.5 Summary .....	110
4.4 A Historical Account of M1's Experiences of Learning and Reading in Two Languages .....	111
4.4.1 Learning and Reading in Chinese at School.....	111
4.4.2 Learning and Reading in English at School .....	113
4.4.3 Reading Practices at University .....	114
4.4.3.1 Reading in Chinese .....	114
4.4.3.2 Reading in English.....	115
4.4.4 Summary .....	117
4.5 A Historical Account of M2's Experiences of Learning and Reading in Two Languages .....	118
4.5.1 Learning and Reading in Chinese at School.....	119
4.5.2 Learning and Reading in English at School .....	120
4.5.3 Reading Practices at University .....	121
4.5.4 Summary of the Four Subjects—RQ 1.....	124
4.6 The Past AS .....	127
4.6.1 'Subject' .....	128
4.6.2 'Object' .....	130
4.6.2.1 Primary and Secondary Education.....	130
4.6.2.2 Tertiary Education.....	132
4.6.3 'Mediating Artefacts' .....	135
4.6.4 'Community', 'Division of Labour', and 'Rule' .....	136
4.6.5 Roles of the Components in the Subjects' Reading Practices .....	139
4.6.5.1 Family Factor—Pre-schooling Stage.....	139
4.6.5.2 The Role of the 'Object' .....	139
4.6.5.3 The Role of the 'Community' .....	140
4.6.5.4 The Role of the 'Rule' and 'Division of Labour' .....	141
4.7 Conclusion.....	141

## Chapter Four: Stories of the Four Chinese Students and the Past Activity System

### 4.1 Introduction

This chapter forms the first of a series of chapters in which the research data that this thesis is concerned with are presented and analysed. Thus, here the four research subjects' past education and literacy experiences are introduced and the activity system (AS) of the contexts within which their literacy practices took place are reconstructed; Chapter 5 describes the AS of the two masters' programmes at Lancaster University in

which the subjects studied, and their literacy practices in general after their arrival in the UK; and Chapters 6 to 8 discuss the details of the subjects' academic reading practices while doing two of their programme assignments, and explore the factors contributing to the shaping of their reading practices.

In this chapter, thus, the past experiences of learning and reading in both English and Chinese of the two MA in Education subjects (E1 and E2) and the two MSc. in Management subjects (M1 and M2) this research is concerned with are first of all described. Then, from an AT perspective, it summarizes the features of the AS in which their reading practices used to take place in the Chinese educational settings. As the chapter unfolds, links will be made to RQ 1 (*What were the main reading practices of the subjects before they came to the UK?*) and RQ 2 (*What aspects in the context (in terms of the AS model) have played what role in the shaping of the subjects' reading practices prior to their arrival in the UK?*). This will in turn provide the basis for the discussions in subsequent chapters: i.e. the data in this chapter will be compared and contrasted with the data concerning the subjects' literacy practices gathered in the context of the AS of each of the two relevant Lancaster University masters' programmes.

## **4.2 A Historical Account of E1's Experiences of Learning and Reading in Two Languages**

E1 graduated from a key university in the southwest of China with a first degree in English Language and Literature. After graduation, she worked for a couple of companies in the south of China for a very short period of time and then settled down as a college English teacher in an east coastal province. She has two years of teaching experience when she started her MA course in the UK. She chose the MA programme in education rather than that in linguistics because: a) she was not satisfied with just

teaching English and would like to be involved in some administrative or policy making jobs; b) the linguistics course she took during her undergraduate years was such a painful experience that it turned her away from any possible further involvement with linguistics courses (Transal:25, 30).

#### 4.2.1 A Book Lover by Nature—Reading in Chinese

Deeply influenced by her family, her father in particular, E1 loved reading since she was very young. In her own words, “I love reading by nature” (天性就比较喜欢阅读. Transal:1). Her father often bought books for himself and for E1 as well, so there was a good collection of books at home, most of which were literary works due to her father’s own interest. Being the only child in the family and with her parents both busily engaged in their work, E1 developed her interest in reading and made it her major pastime. Like her father, E1 was particularly fond of literary works, both ancient classics and modern and contemporary works. She started with children’s picture story books<sup>1</sup> when she was younger, and quickly moved on to tackle ancient classics, such as ‘A Dream of Red Mansions’, which would be considered a great endeavour for a primary school pupil. As time went by, E1’s interest in reading was growing. And reading continued to be her favourite hobby through out the years. She read even a wider variety of books, most of which were contemporary works. Her father’s collection was no longer the only source of books—she borrowed books from libraries and friends, bought books by herself, and joined reading clubs in book stores. She was more selective in the sense that while the pressure of academic study was enormous, she chose to read something light, which could relax her brain; whereas when there was not so much pressure, she read things that were more serious and thought-provoking. But

---

<sup>1</sup> A type of pocket-size publications designed for children, with a big picture (usually black-and-white) on each page and a couple of lines of words underneath. They used to be very popular in China until mid and late 1980s.

she still reread some classics, ‘A Dream of Red Mansions’ in particular, every now and then.

E1 considered her interest in reading highly rewarding in many ways. First of all, due to her extensive reading, Chinese lessons in primary school were simple for her. In lower grades (grade 1, 2 and 3), the main task for the students was to learn Chinese characters, as E1 described, “[we] started with learning Pinyin, and then characters. Up to grade 2 and grade 3, the main task was to learn Chinese characters through texts with Pinyin attached to each character, ... which was very simple for me because I read widely since I was very young and thus knew a lot of characters. (从教拼音开始, 认字, 基本上就认字。…到二三年级, …它主要是通过这种拼音和这种课文来教你认字啦。…这个我觉得对我来说很简单, 因为我从小就有阅读习惯, 所以你就认识很多字。Transal:2)”. Secondly, extensive reading helped E1 to “cultivate good reading habits<sup>2</sup>...and increase reading speed. So I read faster than ordinary people, because the more you read, the faster you can read (有良好的阅读习惯, ... 确实提高阅读速度。所以我看书一般比别人要快。因为你看得多, 你会觉得看得快点。Transal:2)”. Thirdly, reading widely helped her in writing. As she put it,

通过阅读你的认知面肯定比, 尤其是读得多的, 肯定比同龄人的认知面要广, 那么他/她写的时候选的题材就会多一些。而且由于一些, ... 怎么说呢, 就说是象文章的风格呀, 文章的整体意思啊那肯定思想深度啊, 肯定都要比那些阅读少的人要, 要深, 要广, 而且可以引用的东西, 因为大家知道, 在文学作品里面名人名句那你也可以随手拈来啊, 写出来的东西肯定是要比那些阅读面窄的人要好。(transal:8)  
Reading, extensive reading in particular, enlarges one’s scope of knowledge. When it comes to writing, people who read widely tend to have more choices in terms of topics to write about and writing styles, and tend to write in more depth than those who don’t read as much. As we all know, the more you read, the more famous sayings you get to know, which you can quote in your writing, which, in turn, often makes your writing better than those written by people who read less.

But most important of all, she thought that reading contributed to character building and the development of a person as a whole, as she put it, “reading, in a broad sense,

---

<sup>2</sup> By this, E1 meant extensive reading made her love reading even more and hence read more widely, which helps improve her ability of comprehension and reading speed.

influences greatly the construction of one's character, and one's outlook on life and world. (阅读... 从广义上来说呢, 对你这个人的性格, 性格的形成, 品德的培养, 还有就是对个人的那种... 世界观人生观都是很有影响的。Transa1:3).” She went on to argue that “the more one reads, the more deeply s/he understands the culture, and the more s/he will be in harmony with the culture, and in turn, the more s/he will be influenced unconsciously by this culture.” From this point of view, she said she was more purely Chinese than many other Chinese people. She loved Chinese life style and she loved Chinese cultural traditions (Transa1:11).

#### 4.2.2 An Unsatisfied Learner of Chinese at School

As a student, E1 was not satisfied with the Chinese language education at school. In her view, “Chinese language lessons at school are quite a failure (他们的语文课是相当失败的 transa1:4)”, with a main function of increasing the number of Chinese characters that she knew. She thought that the teaching methods were largely “exam-oriented, and the texts have been in use for several decades without any change (还是以应试教育为主, 教的课文都是几十年, 可能课文可以不变的那种 transa1:3)”. Throughout primary school and secondary school years, students were trained to summarize the main idea of each paragraph of the text and the theme of the whole text in a more or less standardized way, which would be considered acceptable by exam markers. To E1, such practice was “ridiculous (transa1:12)”. As she remarked in one of the interviews:

人, 尤其是在心智没有发育特别完全, 一个中学生还不算一个成年人, 而且就算成年人, 他/她对一个事物看法也是有区别的。但它就要求标准答案, 连对语文课上中心思想, 整个文章的意思上面, 它都要求你达到标准答案, 所以这种是高度机械化, 高度教条化的一种教育, 我觉得是这样。不好。

A high school student is not grown up yet, who may be immature both physically and intellectually. Even adults are not likely to have the same opinion about the same thing. And yet the students are required to arrive at a single standard answer concerning the main ideas and central theme of a text. Such rigid and dogmatic way of teaching is not good in my opinion. (Transa1:12)

As far as the textbooks were concerned, although they contained some classic master pieces, there were a lot of texts written with a clear political purpose (e.g. texts



about anti-Japanese war<sup>3</sup>, Chinese civil war<sup>4</sup>, etc.), which E1 thought “are very much out-of-date (很过时的东西 transa1:7)”. Another complaint by E1 was that “the Chinese lessons are too inadequate, ... with too little input. (语文课上...东西太少了 transa1:7)”. In short, she felt the input from Chinese lessons was inadequate not only in terms of quality, but also in terms of quantity.

#### 4.2.3 A Top Student in a Foreign Languages Middle School<sup>5</sup>

E1 chose to apply for a foreign languages middle school not because she was very interested in foreign languages, but because this was a top school in the city, which happened to be located nearer to her home than other good schools. As she explained in one of the interviews:

说实话我个人对英语不是特别爱好，...因为一个人总有一样偏好，你对中国文学的爱好已经占得太多的话，你没有那么多时间的。

To be honest, I am not very fond of English language. As each of us will have our favourite hobbies, I happen to be too occupied with my interest in Chinese literature to spare any time on anything else. I don't have that much time (to develop an interest in English) (transa1:15, my interpolation).

However, lack of interest in foreign languages did not keep her from becoming a top student: she was admitted directly to the senior middle school section from the junior middle school section of the same school without taking the entrance exams, which were designed to eliminate about 60% of all the graduates from the junior section. She was also exempted from the College Entrance Exams and admitted to a key university on the recommendation of her middle school.

There were things that were special in this school concerning the English lessons, according to E1. For example, English lessons were conducted in small classes (e.g. 20-30 students each class compared to 50-60 students a class in other schools). The

---

<sup>3</sup> 1937-1945

<sup>4</sup> 1946-1950

<sup>5</sup> Foreign Language Middle Schools are usually very good secondary schools, which feature foreign language education. There is usually no more than one of such schools in each province, and only very good students can be enrolled.

textbooks they used while E1 was studying there were different from other schools: in the junior section, they used ‘Look, Listen, and Learn’; in senior section, they used ‘New Concept English’ in combination with the widely used standard textbooks (in order to prepare for the College Entrance Exam). During the years in the senior section, students were offered two hours of speaking class each week conducted by native English speakers and two hours of listening and speaking classes to improve their speaking and listening skills, which were rarely available in other schools. Students were also offered a chance to learn a second foreign language during their second year in the senior section. Another privilege for E1 and her classmates was that whenever the students did writing tasks, the teachers discussed with each individual student about the writing s/he had done, though teachers were normally concerned with the spelling, concordance, tenses, and the like. As E1 understood it, the main purpose of writing tasks at that time “besides for the preparation of the writing component in the College Entrance Exam, was to deepen the students’ understanding of grammar and syntactic structures (除了应付高考了那种题型之外, 还有一个就说是, 主要是为了帮助你更加深你对于这个句型语法的认知。Transa1:19)”.

Apart from those differences, E1 described their English lessons as “conducted in a traditional Chinese way of teaching English (很传统的大陆的教学方法, 英语教学方法 transa1:16)”. Take her English lessons in the senior section as an example,

我们老师也是很厉害的一个, 在那个 Nottingham 留学回来的一个老师。虽然也是在英国拿了学位, 但是她还是蛮传统的, traditional 那种的。她会让你还是起来, 叫一个同学起来读, 读完课文, 她会再重新读一遍, 给你纠正你的语音。然后纠正完了以后, 然后就说是就开始把里面重要的单词剔出来讲。讲的时候会很详细, 这个单词比如说是及物还是不及物的, 动词的话。名词的话她会给你所有的单词会给你出例句, 让你搭配, 然后再请下面同学起来自己举例句来搭配。讲到词组的话, 会给你讲这个词组的用法, 然后给你归一下类啊, 例如说这个词组和那个词组意思差不多。就是, 就是差不多这样的语法词汇的讲解。讲解完以后, 然后再, 然后她一般会上课前会, 先默写, 默写上节课的单词和一些语法现象, 然后讲课讲完了这节课以后, 她会布置下节课的作业, 然后再发一些 handout 让你做。

Our teacher was a very good one, who graduated from Nottingham University. Although she got her degree in the UK, she still taught in a very traditional way. (Normally), she asked a student to read (the text). And she read it again by herself in order to correct our

pronunciation. After that, she teased out some important words for detailed discussion, e.g. differentiating transitive verbs from intransitive verbs, giving sample sentences to illustrate the usage of nouns, asking students to think of collocation of certain words and making sentences with them, summarizing uses of phrases and listing some more phrases with similar meaning, etc. Usually at the beginning of each session, she checked whether we had mastered the new words and grammar from last session by asking us to write down those words and grammar rules from our memory. At the end of each session, she set the after class tasks and gave out some handouts (exercises) for us to do (transal:16, my interpolation).

As mentioned at the beginning of this section, E1 was not particularly interested in English. Nor was she enjoying reading in English. Or to be more accurate, E1 had “no time to read and no access to (第一是没有时间, 第二是没有来源。transal:15)” interesting readings in English. The only readings she did in English was for doing reading comprehension exercises, which was not interesting at all as part of her exam preparation. She commented that whether the reading was easy or difficult depended on whether she could answer the questions correctly rather than whether she understood the content of the reading. However, she later admitted that even if she had time for and access to anything interesting in English (as she did during her undergraduate years), she would prefer to read the translated versions in Chinese instead of the original English versions. As uninterested in English as she was, E1 was admitted to a key university on the recommendation of her middle school<sup>6</sup> to study English Language and Literature. As a graduate from a foreign languages middle school, she could only choose to study a foreign language if she wanted to be exempted from the College Entrance Exams. And the primary reason for her to accept the offer was that the university was situated in the city where her parents originally came from and most of their relatives still live.

#### 4.2.4 A ‘Careful Investor’—Literacy Practices at University in China

E1 enjoyed much more freedom at university than in middle school. For instance, she could choose to go or not to go to a class, to listen or not to listen to the lecturer in

---

<sup>6</sup> Only top students from good middle schools can be admitted to key universities without taking the entrance exams.

class, to read or not to read in preparation for a lecture, etc. as long as she could manage to pass the exams or other forms of assessment. E1 was very careful about the investment of her time and energy, i.e. she never read anything that did not interest her except for the preparation of exams a couple of weeks before the exams, and she was often absent or at least absent-minded in lectures that seemed boring or useless to her. Most of the courses were assessed by exams, and E1 usually managed well by studying textbooks and/or lecture notes (more often than not, copied from her classmates) shortly before the exams<sup>7</sup>. She was happy with her way of study (though she could not possibly have learned much in this way<sup>8</sup>), because the courses did not seem interesting or to have any use for her in the future.

The only courses that were interesting and challenging enough to encourage her to read before and/or after the lectures were courses like ‘The Selected Readings of English and American Literature’, ‘The Selected Readings of English and American Poetry’, and ‘History of English and American Literature’. One reason for this might be that she was generally more interested in literature than anything else, as was evident in the way she chose her reading for pleasure. It could also be that this was an area that she was not very familiar with and thus would like to know more. She also had courses on ancient Chinese literature and historical documents, but she did not seem to do reading in relation to those courses because that is an area she already knew quite well and read widely before. Besides, those Chinese courses were not demanding enough to make her feel the necessity of doing reading for preparation of lectures—as she mentioned: “I am interested in them (e.g. ‘Ancient Chinese literature and Historical Documents’). But to be honest, those courses were too simple... I already read most of the stuff discussed in class (这种是我比较感兴趣的, 但说实话我觉得它讲的程度太低, 它讲的东西我都看过

---

<sup>7</sup> Study usually meant learning by heart in such cases.

<sup>8</sup> As she mentioned she forgot most of the things that were taught during that time.

transa1:20)”. The most important reason probably was the way the lectures were delivered. As she mentioned a few times in her interview, she liked the courses by one particular lecturer very much, who taught ‘Selected Readings of English and American Poetry’ and part of other literature courses, because his lectures were

very insightful and interesting. ... He often appeared to pay no attention to anyone else in the classroom, or to the students’ reactions. I appreciated greatly his way of lecturing—sitting on the desk and talking about his understanding (of certain poems and poets). ... He was very learned, and gave very good talks, which kept attracting students’ attention. ... He seldom paid any attention to the students’ reactions ... but you gained a lot of knowledge from his talks (讲的很精辟的那种，讲得很有意思。... 这个老师是那种旁若无人型的，他也不管学生反应，我就很欣赏他那种很洒脱的那种，坐在桌子上就开始讲他的理解啊。... 因为人家有水平，他能讲得很好，吸引学生听下去... 他不太注意学生的感受，... 但是你能从他讲，你能获得很多知识。Transa1:24-25, my interpolation).

In contrast to her calculated effort on academic studies, as she summarized for herself: “my reading in English related to my academic study was very limited; reading in English that was not related to my study was none (和课相关的总结起来就是，和课相关的我的阅读量是非常 limited，和课不相关的是 none.Transa1:27)”, she ‘invested’ generously on reading non-academically, which was always in Chinese. At this stage, she read more widely in terms of the types of books she chose to read, ranging from “easy and light Kong Fu novels to complex and profound books on philosophy by people like Kant (从最低层次的特别滥的武侠小说，一直看到包括一些康德的一些哲学啊，... 比较深奥的哲学书啊都看过。Transa1:27)”. She described herself as being “rebellious—a furious youth—during her undergraduate years (大学时候都是有种，叛逆心，愤青的那种感觉 transa1:21)”, reading a lot of things attacking current social and political situations, which she thought was something that a university student should do, rather than following the conventions and doing what his/her parents and teachers thought appropriate. But she still reread ‘A Dream of Red Mansions’ once every year, and also reread some other books that she thought good (transa1:21).

As far as writing is concerned, there were not many essays that they needed to write in Chinese, except for the exam of the Chinese writing course where they were asked to

write two essays in 2 or 3 hours. In the English writing courses, they were asked to write short essays, imitating the writing styles of famous writers. And while taking the English and American literature and poetry courses, the lecturers sometimes asked them to write short stories and poems. However, the only lengthy academic essay they wrote was the dissertation during the last year. E1 chose to write her dissertation on a comparison of two novels—‘The Adventure of Huckleberry Finn’ and ‘The Catcher in the Rye’. She had a few months’ time to finish it, yet she kept postponing to start working seriously on it till a week before the deadline. She managed to submit it on time and get passed. The result was not satisfactory according to her past academic record, but she thought the mark was fair considering the effort she put into it. This experience of hers reconfirmed that she seldom invested more than necessary time and energy on anything which did not seem interesting or worth doing except for getting a mark.

#### **4.2.5 Summary**

E1, influenced by her father, loved reading and read widely in Chinese since she was young. In other words, she had a ruling passion for Chinese literature so much so that she did not like reading in English at all. She thought very positively of the function of reading in the development of a child as a human. In her case, reading enlarged her vocabulary, broadened her vision, improved her writing, and deepened her understanding of and love for Chinese culture. She felt unsatisfied with Chinese textbooks for not providing adequate and up to date language input compared with other readings she did after school. She criticized Chinese lessons and teachers for being rigid in teaching Chinese reading. However, her disapproval of Chinese education at school did not prevent her from becoming a top student. Moreover, despite her lack of interest in English, she did very well in a foreign languages middle school and was admitted to

the English Department of a key university without taking the College Entrance Exams. Since she was not interested in her subject area (English Language and Literature), she was not very keen on study, nor on reading related to her study, which meant she seldom read in English. However, she read even more widely in Chinese due to more free time at her disposal during her undergraduate years, and at the same time managed to get satisfactory academic results. On the whole, E1's experiences seemed to show that she was confident in her academic ability and judgment, and seemed able to manage her study well, even though she did not approve the way in which she was taught, or make full effort on her study.

Having described E1's education and literacy history, I turn next to E2's history of education and literacy practices.

### **4.3 A Historical Account of E2's Experiences of Learning and Reading in Two Languages**

E2 graduated from a teacher's university in a big city in the east coast of China with a BA in History. She came to the UK right after graduation with a hope to get a better job with another degree from a UK university. According to her, she did not want to be an ordinary history teacher since history is only a minor subject in secondary schools. She would like to be a teacher of a major subject (i.e. Chinese, maths, and English)—an English teacher in her case. Even though she might not teach English, with improved English after a year's study in the UK, she hoped to teach history in a bilingual school (transb1:1).

#### **4.3.1 A Reluctant Reader**

When she was young, E2 lived with her parents and her grandparents. Her mother ran a small business of her own and spent a lot time on it, and her father was often away from home as a seaman. Her grandparents were her primary caretakers, who were not

very concerned about her early education and school performance. They were not particularly interested in reading themselves and there were not many books at home. They did not encourage E2 to read, either. As a result, E2 read very little (transb3:1, 3). According to her, “during my childhood, except for reading for school work, I spent most of my time playing (我童年的时候, 除了学校正规念书, 我都是玩的. Transb3:3)”. Only occasionally did she read some fairytales and stories because she liked listening to the stories her grandfather told her before she could read by herself. After she started secondary school, she read some romantic novels and cartoon books, because they were very popular among the students at that time and they were easy to read. But she was not as enthusiastic as her classmates (transb3:9). She also reported that she seldom read newspapers, magazines, or classics; and she never went to the school library (ibid). She loved watching TV. As she put it, “I probably spent all the time that I should have spent on reading on watching TV instead (我所有阅读的时间我估计都用在电视上了 transb3:10)”.

E2 believed that “there were internal and external factors that contributed to the fact that she did not read a lot when she was young—lack of personal interest (internal) and lack of nurturing and encouraging environment<sup>9</sup> and adult guidance<sup>10</sup> (external) (一个我觉得是个人的兴趣吧…我就是没有兴趣…还有一个我觉得是要有条件, 有这个环境, 有这个氛围, 我觉得是这样的。因为我完全就没有人告诉我要看, 我觉得还是要有一定引导。 Transb3:6)”.

Although not interested in reading, she still read some fairytales, story books and novels as a school girl. Since she had little interest in reading, she always needed someone to arouse her attention to those books. For instance, her grandfather told her stories such as ‘Snow White and the Seven Dwarfs’, ‘Cinderella’, every night while she

---

<sup>9</sup> Her family members were either constantly absent (her parents) or not fond of reading (transb3:3).

<sup>10</sup> No one ever encouraged or guided her to read extensively (transb3:6).



was young so that she was attracted to them; a neighbouring girl had fairytale books which E2 could borrow; many of her classmates at secondary school read cartoon books and romantic novels, so she started reading them, too (transb3:3,9,10). Gradually she seemed to enjoy reading those books, and was even a bit addicted to some of them. However, she was still not as enthusiastic about reading as some of her classmates were (transb3:7, 9, 10).

### 4.3.2 An Average Student Who Loved History

E2 described herself as “an average student, and sometimes even a bit below average (我念书一直是很平均的, 很中等的, 甚至有时候是中下的那种水平。Transb3:1)”. She “did not hate going to school, nor did she love going to school (我就是不厌学, 不觉得上学很痛苦, 但是也不是很热衷。Transb3:6)”. She was happy about her school performance as long as she did not fail any exams. She never pushed herself for better performance, nor did her parents set any expectations for her (transb3:5). Therefore, after school, the only homework she did was what the teachers clearly told the students to do. She never bought any extra exercise books, nor did she do any extra school work in her spare time (transb3:5, 10).

However, there was one subject that she was particularly interested in—history. She became fond of history since she had her first history lesson at secondary school, because her first history teacher delivered excellent lectures. She thought her interest in history might also result from her childhood experience of listening to stories. Even now, she still considered history as stories—interesting stories (transb3:9, transb4:12). She enjoyed reading history textbooks and read them so often that she was very familiar with the contents of the textbooks. Besides, she also liked reading history novels, which were fictions based on history, but not always true to history (transb4:12). Her interest in history led her to choose it as the fourth subject in addition to the other three

compulsory subjects<sup>11</sup> for College Entrance Exams, and as the subject area for her undergraduate studies (transb4:10, 12).

### 4.3.3 Learning of Two Languages

#### 4.3.3.1 Learning Chinese

As far as she could remember, at primary school, the main purpose of Chinese lessons was to teach students the Chinese characters, new words, sentence making, and to develop students' ability to use the Chinese language idiomatically (你主要学的就是…学汉字, …学生词, 学造句, 学那种我们汉语那种语感. Transb3:5, 7). In lower grades, they focused more on Pinyin, new characters and words (语文课是先学拼音, …接着么就是什么教写汉字, …有很多生字. Transb3:3); later on, the focus was more on text analysis, such as dividing the text into several sections, summarizing the main ideas of each section, analysing the theme of the whole text, etc. (transb3:4, 7). At secondary school, the Chinese lessons mainly focused on reading comprehension, which was more than simply finding out the main ideas of each section of a text, ... and which was tested in Chinese exams (transb3:8, 9). E2 thought it difficult for teachers to teach reading comprehension, though in class, the teacher tried hard to help the students understand the texts, for example, by asking questions such as “why did the author write it this way”, “what was the author thinking about while s/he was writing”, etc. (作者为什么要这样写, 她/他当时心理是怎么样的. Transb3:9). When she looked back at those Chinese lessons, she considered it a very happy experience to have such lessons, with the teacher helping and guiding her to read, analyse and discuss a text with other classmates, though she did not think so at that time (transb3:15).

---

<sup>11</sup> There were four subjects that each student had to choose in the College Entrance Exams. The first three were compulsory, which were Chinese, maths and English. Students could choose the fourth subject according to their own strength.

She started learning to write in Chinese at primary school, during which time, the students' main task was learning to write narratives and descriptions of people, objects and events (e.g. "an unforgettable event, my favourite animal, my father, my family, ... an unforgettable journey/holiday, and so on. 小学比如说一件令你难忘的事啊, 还有什么你最什么什么的人啊, 你爸爸, 你的家啊, 你喜欢的, 最喜欢的一样小动物啦, ...一次难忘的旅行啦, 假期啦" transb3:11). Good writings should contain vivid descriptions with beautiful words and sentences according to her teachers, as far as she remembered (transb3:12-13). When she first started secondary school, she continued writing narratives of similar topics as she did at primary school, but with more complex structure and contents (transb3:12). Soon after, argumentative writing was introduced to students and became the primary genre of students' writing throughout the secondary school stage. She remembered quite clearly that her teachers talked about the structure of argumentative writing in class: for instance, one should raise the issue under discussion or bring forward one's opinions in the first place, followed by some supporting arguments, and finish with a conclusion, but she could not remember whether and how the teachers had taught them to write narratives (transb3:12, 14).

#### **4.3.3.2 Learning English**

Her attitude toward learning of English was similar to her attitude toward schooling in general—neither like, nor dislike. She did not start learning English until her school arranged English lessons in grade three at primary school. She never did any extra work on English in her spare time except what her teacher told her to do (transb4:2). According to her: for each lesson, the teacher usually talked about new words, phrases, texts (or dialogues sometimes), grammar, etc. and then checked the exercises with the students. The students needed to do exercises in both textbooks and exercise books. They also needed to copy new words and learn texts by heart as part of their homework

(transb4:2). As for reading in English, the only thing she read was textbooks and exercise books, since she was generally not interested in reading. At senior high school, reading comprehension became an important part of English exams, and she always timed herself while doing reading comprehension exercises in order to estimate how well she could perform in real exams. She usually did well in questions about details, but might make mistakes in questions about main ideas (transb4:5). They started English writing at secondary school, though she did not have the impression that the teachers had particularly talked about writing in class. The students were not asked to write in English often. In addition, the English writings were usually short and simple (e.g. sometimes 30 or 40 words were enough), which were not as long and as in depth as the Chinese writings they were expected to produce.

#### **4.3.4 Literacy Practices at University**

Since she was not very enthusiastic about study as a rule, she was not very keen on academic reading at university (transb4:15). As a history student, she had various history courses, such as ‘Chinese Ancient History’, ‘Chinese Modern and Contemporary History’, ‘World History’, ‘World Cultural History’, ‘African History’, etc. (transb4:14, 16). But she did not need to read her textbooks a lot, since she was already familiar with many of the contents from her study at secondary school. For those new contents, she read them as stories or novels (transb4:14). She read history textbooks as novels and learned some of the contents by heart before exams. For elective history courses, the teachers usually provided a reading list, instead of textbooks. She did not read anything from the reading lists at all, unless when she needed to write essays for assessment (transb4:15, 16). She had some courses on education because her area of study was history education; she also had to take courses that students of all subjects were required to take (such as ‘Politics’, ‘Moral Education’). She never read anything for those

courses, expect for preparing for exams or writing essays, or unless the textbook was really interesting (transb4:15).

Besides textbooks, she read books on culture, customs, historical figures, etc. which were also related to her subject area, as a type of leisure reading. She liked reading newspapers, magazines, and novels at that time; and she even read some masterpieces, such as 'A Dream of Red Mansions', 'Jane Eyre', 'Gone with the Wind', 'Pride and Prejudice', etc. (Transb4:17, 18). She read much more widely at university than at secondary school, which she thought was due to three reasons: firstly, exam-oriented education was not prevalent at the tertiary level; secondly, she enjoyed more free time, which she could spend on reading; thirdly, she found herself especially weak in her knowledge about books (literary works) compared with her classmates, and she thought it necessary to read more in order to be able to exchange ideas with others about various books (transb4:23).

During her undergraduate years, she wrote about a dozen of academic essays (in Chinese) for various courses and for her final degree (Transb4:17). To write an essay, she usually decided on a topic first, and then started searching references and then read in order to write (transb4:15, 16). Generally speaking, for an essay of two to three thousand words, she had three or four references (transb4:16). She went to the library to search for references in a similar way as she was doing in the UK, i.e. key word search (transb4:16). She reported that she had to read in order to use the arguments in the references. Moreover, she also needed to structure the essay and to form her own opinions in addition to copying from the reference sources (transb4:16). However, she did not think it difficult to write those essays—she usually finished an essay within two or three days; nor did she think it difficult to find and read reference books and articles

because they were all in Chinese (transb4:17).

Although she did not have Chinese lessons at university, she was required to take a Chinese writing class, in which the students were taught how to write essays in general, and academic essays in particular (transb4:13, 14). She remembered that the tutors talked about how to search references, how to organize an essay, and so on. But there was only one session of an hour and half each week, which she thought insufficient for such a course (transb4:13). She thought the writing course very important, but not effectively conducted. Firstly, the students did not always do what the tutors asked them to do, so that the course was not as effective as the tutors had expected. Secondly, the course was offered in the first year, when the students did not have any courses which were assessed in the form of essay writing. As a result, when the students started writing essays for various courses from their second year, they probably had forgotten what they had learned in the first year (transb4:13).

According to E2, English lessons at university were taught in a similar way to those at secondary school—the teacher talked about new words, texts, and exercises (Transb4:20). She reported that the teachers spent much time on explaining new words, and there were not many grammar rules that were new to the students (transb4:20). Before class, she usually previewed the texts by reading a reference book, which provided detailed discussion of vocabulary and Chinese translation of the texts (transb4:20, 21). Most of the reading in English that she did was doing reading comprehension exercises for the preparation of CET-4, and CET-6<sup>12</sup> (transb4:21). Apart from that, she tried to read English newspapers—21<sup>st</sup> Century, and Shanghai Star, and an English novel—‘Jane Eyre’, but she gave up reading them very soon and never

---

<sup>12</sup> College English Test Band 4 and Band 6 are nation-wide examinations for college and university students in China. The certificate of CET-4 is a prerequisite for the award of bachelor's degrees.

finished any (transb4:22, 24). She also read a book on English composition when she was preparing for the CET-4, and CET-6; and teachers seldom talked about English writing in class, as she recalled (transb4:22).

### 4.3.5 Summary

To sum up, E2 has always viewed herself as an average student who did not strongly like or hate learning. She seemed to trust others' (e.g. teachers, grandparents, parents, peers) advice and judgment more than her own. As a result, she played a rather passive role in learning and reading. For instance, she was used to following teachers' instruction closely, i.e. she only did what the teachers clearly told the students to do, without making any extra effort in trying to do better at school; she did not like reading because nobody told her it was good to read; she started reading when she found her reading much too limited compared to her peers, but reading was never quite an important part of her life.

Also worth mentioning was her particular interest in history thanks to her first history teacher who delivered very vivid lessons, and she has never lost her interest in history ever since then. Her interest in history was the ruling passion driving her to read. She started reading history books as if reading stories and kept this habit from then on. This interest of hers also led to her choice of history as the subject of study at university. E2's attitude toward study at university was similar to E1's in that neither of them would make special effort just in order to get good academic records. They only wanted to do what was necessary to get through all subjects.

E1 and E2's accounts show that there were similarities in their educational experiences due to the fact that they were educated under largely the same education system; yet individual differences still existed and influenced their attitudes towards learning and reading, which led to different personal experiences in these areas. Next, I

will consider to what extent this was also the case for the two subjects in the MSc. in Management programme—M1 and M2—by presenting and analysing similar information concerning their background experiences.

#### **4.4 A Historical Account of M1's Experiences of Learning and Reading in Two Languages**

M1 studied in a polytechnic university in South China and had a first degree in English for Science and Technology. He had planned to study Computer Science for his master's degree abroad right after his graduation, which was delayed by the outbreak of SARS. He worked as a web programmer for a company while he was preparing for his study abroad. His senior colleagues made him realize that being a manager had a better future than being a programmer. Therefore, he made up his mind to choose the MSc. in Management programme at Lancaster University, which is designed for those without a management background (transc2:8).

##### **4.4.1 Learning and Reading in Chinese at School**

M1 recalled that at primary school, learning of Chinese started from learning Pinyin and Chinese characters. At first, texts were simple and the main task was to learn new characters. His Chinese teacher usually explained every sentence in the texts. From Grade Four onwards, the emphasis shifted to analysing the structure of a text, and the main ideas and messages it conveyed. The teacher started asking students questions about division of a text into sections, main ideas of each section in a text, the central theme of a text, etc. and at the end the teacher would always give a correct answer (transc1:3-5).

At junior high school, the texts became more complex and were of various genres<sup>13</sup>.

---

<sup>13</sup> The majority of texts at primary school were narratives.



There were many argumentative texts. Prose in ancient literary style also became an important part of the texts that students were asked to learn. At that time, his Chinese teacher asked students questions as a way to help them understand the texts. The questions were mainly concerning the structure of a text, main ideas of each section in a text, underlying meanings of certain sentences, rhetorical devices employed by the authors, the central theme of a text, and so on. At the end of each unit, which consisted of a few texts of the same genre, there was a summary of how to read and write texts in this genre. M1 considered the methods of reading introduced in the summaries as more systematic in analysing texts, but also more time-consuming. He could only stick to such methods for a short time before he shifted back to his usual way of reading—i.e. read on and on, simply marking what he could not understand or what he thought important (transc1:9-11).

At senior high school, Chinese lessons were totally tailored to exam preparation. As M1 commented in an interview,

那时候，语文老师强调的我们要学的东西，大多数都是高考卷子上会出现的那种阅读理解的题目，即使老师想讲其他的，可是时间不允许，因为高中那三年，大家都是为高考而奋斗。

At that time (senior high school), what our Chinese teacher asked us to think about (while reading and analysing a text) was the kind of questions that would appear in the College Entrance Exams. ... Even if the teacher had wanted to talk about other things in class, there would not have been time for that, since during all the three years, everyone was working for only one goal—the College Entrance Exams (transc1:13-14, my interpolation).

M1 was not particularly fond of reading especially before he started secondary school. He had no interest in reading and only read while his mother or sister asked him to (transc1:2). He did like reading one thing since he started Grade Five—collections of excellent writings by primary school pupils, because he would like to learn from other pupils the way of organizing a text, choice of words, and making of sentences (transc1:5-6). At junior high school, he occasionally read stories and popular science, but he was still not enthusiastic about reading (transc1:15). He found interest in reading only after he entered senior high school, when he felt an urgent need for increasing his

knowledge (transcl:18). He became interested in news and all kinds of things. Sports magazines were his favourite ever since then (transcl:15, 18).

He noticed his increasing interest in reading, but he himself could not explain why that was the case (transcl:15). By looking at his interview data, I would argue that an important reason for this was the need to socialize with his classmates and friends. According to him,

那时候，因为跟同学交流的比较多。这个星期例如我看过读者，然后我又看过足球类的，体育类的，然后我觉得重要的东西都划过线，在杂志里面，然后下个星期同学看其他的，然后我们交换。... 例如足球方面有哪些明星，或者某个俱乐部什么辉煌历史之类的我都会背下来。

At that time (senior high school), we very often exchanged information gained from reading among fellow students. For instance, I read the magazine 'Reader' and sports magazines this week, underlining what I thought important information, and then I would tell my classmates what I learned from reading them and they told me what they read. We went on like this week after week... I would try to learn by heart history of football clubs, names of football stars, etc... (transcl:18).

The part of the data quoted above seems to indicate that M1 would like to present himself to his friends as knowledgeable and able to contribute to others' knowledge. In order to remain an in-group member of his social circle, he needed to update his knowledge constantly, which might be a great incentive for his reading. In addition, his lack of interest in outdoor activities during his secondary school years and the need to relax himself from the pressure of study (transcl:15) might have helped his developing of an interest in reading.

#### 4.4.2 Learning and Reading in English at School

The primary school that M1 went to started giving English lessons from Grade Four. The textbooks were from Hong Kong, which focused on developing students' ability of using the language. Generally, in class the teacher only talked for about ten minutes and left all the rest of the time for the students to do activities and dialogues. As a result, after they started secondary school, M1 and his school mates did better in listening and speaking in English than pupils from other schools, who used traditional textbooks in mainland China. However, M1 also found that his vocabulary and grammar was weaker

than those from other primary schools due to the same reason (transc1:19, 21). At junior and senior high school, M1 found English lessons much less enjoyable than those in primary school. His English teachers emphasized grammar, vocabulary, and the like, which were to be tested in exams. In senior high school, the texts became longer and the lessons more oriented to exams (transc1:21, 25). M1 recalled that occasionally, his teacher taught them some techniques of reading texts for reading comprehension questions in exams, but did not talk about how to read texts in textbooks (transc1:26).

English was the subject that M1 was most interested in among all subjects throughout his primary, secondary and tertiary education, for which he again could not account (transc1:20). At primary school, his English teacher, who was very friendly with him, often offered him extra readings such as stories and popular science that were suitable for primary school pupils. M1 did not mind what the reading was about as he was so fond of English that he liked reading anything in English. In this way, according to him, he also improved his English. At junior high school, besides English textbooks, he read supplementary materials for learning English, in which there were also short texts for him to read. Reading of those texts helped enlarge his vocabulary, improve his ability in doing exam questions, and increase his knowledge in general (transc1:23). At senior high school, he hardly had time to read extra English texts, except while doing reading comprehension exercises for exam preparation (transc1:26).

### **4.4.3 Reading Practices at University**

#### **4.4.3.1 Reading in Chinese**

M1 studied English for Science and Technology for his first degree. Among the courses he was required to take, there was a Chinese course, which was designed to lay foundation for their translation courses. The teacher asked the students to pose questions on her concerning the texts they were asked to read. There was no restriction

as to what kind of questions should be asked, so the students often asked questions that were quite irrelevant to the texts. At the end of a lesson, the teacher would mention things that the students missed to ask about, yet she thought necessary to draw the students attention to, such as good expressions that might be useful for their translation (transc1:28). M1 did not preview the texts before class, but he did simple review after class. He also studied for a minor degree in Computer Science, the course books of which were all in Chinese, and he read them quite a lot. Apart from that, reading in Chinese for academic purposes only took place a couple of weeks before the end of term for exam preparation (transc1:30).

Non-academic reading in Chinese was not done very often during his undergraduate years. One of the few things that he read in Chinese was works by Confucius, Mencius and the like in classical literary style. He found himself increasingly interested in reading those classics because he liked the thoughts in those works, which provided him with useful guidance in many aspects of his life, and so he read more and more such works in his spare time (transc1:30, 47). He used to read all kinds of news in Chinese before, but now he read news in English instead, since he chose English as the subject of his study and one of his tutors required them to do certain amount of reading in English after class. Since then, he became used to reading news in English because it enabled him to gain information and fulfil the tutor's reading task at one time (transc1:38, 42).

#### ***4.4.3.2 Reading in English***

As a student of English, especially a diligent student like M1, he had a lot to read in English—not only the textbooks, but also other supplementary materials. For instance, the textbooks for one of his major courses—Intensive Reading, contained papers in various areas of science and technology. While reading a text before class, he had to read some background materials in the area that the text involved, or to consult friends

specializing in that particular area, or otherwise, he could hardly understand the text (transc1:35). In class, his teachers of this course usually asked the students to critique the texts they were reading by discussions among themselves on questions such as why the authors made certain arguments and whether and why they (the students) were for or against the arguments. Students were also expected to be able to translate the texts into Chinese after the discussions in class (transc1:36).

Extensive Reading—another main course—was designed to develop students fast reading skills such as skimming and scanning (transc1:39). In class, students were asked to read newspaper and magazine articles and the teacher then checked whether they grasped the useful information from those articles (transc1:39). After class, the teacher assigned quite a few reading tasks to the students, including three novels a term with one presentation concerning each novel, and readings in English newspapers and magazines or websites of the students' choices. Accordingly, M1 and many of his classmates started reading English versions of news, magazines and websites, which they were interested in and which they used to read in Chinese (transc1:40-42).

Literature course was another one among the courses that influenced M1's reading. M1 had never had any interest in literary works either in Chinese or English. At first, he did not enjoy reading novels that the teacher assigned them to read and he could not appreciate the novels in a way that the teacher taught them to in class, i.e. try to find out the hidden meanings of the words. Gradually, he tried to appreciate the literary works in the way taught by his teacher and started enjoying them, which made him believe heartily what his teacher once said "if you don't like literary works (in English), that's only because your English is not good enough (to appreciate them)" (transc1:42). M1 also found that his life experiences also restricted his understanding of the literary works and believed that had he had more social experiences, he would be able to

appreciate them more fully and deeply (transc1:44). After taking the literature course, M1 became interested in reading short stories in English. He got himself some short stories to read and tried to follow his teacher's way of reading. He even searched the Internet for pieces of literary criticism related to what he read to check his understanding (transc1:43-44).

The picture presented above seems to suggest that his reading in English for academic and non-academic purposes was mingled together and could not easily be separated from each other. For example, reading of English news and websites gave him information and helped him do the fast reading exercises that his teacher required the students to do. Reading of English short stories brought him enjoyment as well as a means of learning to appreciate literary works. As mentioned earlier (in 4.4.2 above), English was always his favourite subject, and he enjoyed reading in English. During the first and second year at university, he would still attend to the new words and sentences while reading in English. In the last two years, he became so used to reading in English that he read them as if he were reading in Chinese, paying attention to the content only (transc1:49).

#### 4.4.4 Summary

On the whole, M1 did not read much while he was young<sup>14</sup>, even though his mother and sister encouraged it. Instead, he preferred outdoor activities at that time. After entering secondary school, M1 gradually lost interest in outdoor sports such as soccer, and the reason for that was something he himself could not account for. However, he was still interested in reading about sports and was eager to exchange his knowledge with his friends (see 4.4.1 above for more discussion). In fact, he was always interested in reading about sports—a passion for sports in other words, and had later extended his

---

<sup>14</sup> Before entering secondary school.

interest to include current political, economic, and social issues all over the world. He also tried to read books that may potentially give him guidance for his future life.

M1 considered English as his favourite subject at school, and hence chose English as his major at university. He seemed very enthusiastic about reading in English after he started learning English—another ruling passion of his, so much so that as long as something was written in English, he would like to read it (see 4.4.2 above for more details).

M1 seemed to be a very diligent student who would like to spend much time on his study even when there was not much external pressure of high stakes exams. For instance, at university, he always tried to fulfil tutors' requirements for reading and other tasks, and would not mind making extra effort in order for better achievement than just being average. He also tried to make links between his study (what he studied) and his life (potential uses of the knowledge in his life after graduation).

Having presented M1's "story", I turn finally to M2's account of her education and literacy experiences before she came to the UK. This will then be followed by a summary of the four subjects' reading practices in answer to RQ 1.

#### **4.5 A Historical Account of M2's Experiences of Learning and Reading in Two Languages**

M2 graduated from a university in the southwest of China, with a BA in English Language. Influenced by her parents who were running a company of their own, M2 would like to enter the business world, but found her undergraduate studies did not prepare her for the business jobs. That was the reason she chose to do the MSc. in Management programme as it did not require any prior knowledge of management, and prepared students for jobs within the business management field (transd1:10).

### 4.5.1 Learning and Reading in Chinese at School

Similarly to E1, E2 and M1, at primary school, M2's Chinese lessons involved learning of Pinyin, characters, sentence-making, etc. In class, students were asked to read the new characters, words, and texts aloud, to divide a text into sections and to summarize the main ideas of each section and the central theme of the whole text. At secondary school, her Chinese teachers put more emphasis on the analysis of the implied meanings of a text and the rhetorical devices (transd3:3-4, transd4:2). M2 usually previewed a text before class, except at senior high school when she did not have enough time for this. While doing preview, she tried to learn new characters, new words and their Pinyin equivalents, to make sentences with new words, and to divide the text into sections. In this way, she would be more ready to answer questions that the teachers might pose in class. She sometimes read reference books accompanying the textbooks to help her understand the texts and to give her sample sentences made with new words and some sample answers to questions about the text (transd3:6, transd4:1).

M2 considered her reading after school as very limited (transd3:2). She thought it was because her grandma<sup>15</sup> did not encourage her to read anything extra to textbooks as long as she learned the textbooks well and got good exam marks, and M2 herself preferred outdoor activities to reading (transd3:2, 6). Her father once bought her a set of colourful fairytale books, which aroused her interest in fairytales. Later on, she read quite a few such books during her primary school years, and even kept on reading some of these stories at junior high school (transd3:3). She also read some teen magazines. Due to her interest in cultures of foreign countries, she read various magazines featuring foreign cultures. After she entered senior high school, she seldom had time for reading for pleasure. During summer holidays, however, she read some classic masterpieces,

---

<sup>15</sup> M2's parents both had busy jobs, and M2 spent most of her childhood with her grandparents.



such as ‘Pride and Prejudice’, ‘Jane Eyre’, ‘The Hunchback of Notre Dame’, etc. because her teacher said reading those books would do them good. She also read biographies of a couple of writers that she liked at that time under the influence of her friends. In addition, she read supplementary materials that helped her with her study at school and for preparation of various exams (transd4:3-4).

#### **4.5.2 Learning and Reading in English at School**

M2 recalled that she liked English very much when she started learning it (transd4:7). In the summer before she entered junior high school, she attended an English course—her first encounter with English—for a month, where she learned the alphabet and some simple dialogues (transd4:5). At junior high school, during the first year, students were mainly learning dialogues, and new words that appeared in the dialogues. From the second year onwards, there were both dialogues and a short text in each unit. In class, the teacher usually asked the students to listen to the tape with recorded new words and texts, and then to read them aloud. The teacher then explained the new words, talked about the sentence structures and grammar appearing in the dialogues or texts, and translated the texts into Chinese. The teacher also sometimes played games with the students or taught them to sing English songs in class (transd4:7). M2 spent quite a lot of time on English: she previewed each lesson before class—trying to learn the new words and texts by heart, and to understand the texts and grammar; she did a lot of exercises in the exercise books accompanying the textbooks and in extra supplementary materials; she often listened to the audio tapes of the textbooks at home; she also read short stories and jokes in the supplementary materials (transd4:7-8). Besides her interest in English, being the assistant to the English teacher was another important reason for her spending so much time on it, because her classmates usually turned to her, instead of their teacher, for help when they had questions, and they read

after her in the reading-aloud session every morning (transd4:8-9).

According to M2, the difference between English lessons at senior high and junior high schools mainly lay in the way grammar rules and word uses were taught and tested: i.e., at senior high school, the grammar rules and word senses were more finely classified and were explained in more detail, and in addition, the exceptions of general rules were particularly emphasized (transd4:6, 9).

At senior high school, M2 continued to spend much time on English. She regularly consulted a reference book recommended by her teacher while previewing and reviewing English lessons, which provided a lot of supplementary materials for the textbooks, such as extra new words, more detailed explanations of grammar rules. She read ‘New Concept English’ to further improve her English. She also read a few simplified versions of classic literary works in English. What she did most in her spare time was, of course, doing loads of exercises for the preparation of various exams and contests. She also did a lot of listening exercises, and sometimes let the tape keep playing while she was doing something else (transd4:10-11).

### **4.5.3 Reading Practices at University**

As a student of English Language and Literature, the majority of the courses were conducted in English, and the readings for those courses were all in English, too. Among them, the ‘Intensive Reading’ course was run throughout the four years. M2 usually studied the texts in the course books both before and after class—she looked up new words in a dictionary, and tried to translate the text into Chinese as her teachers often asked the students to translate in class; after class, she went through the texts again and tried to recall the teacher’s version of the translated texts. She would also consult the reference books designed especially for the course books to help her understand the texts (transd5:1-2). In class, the tutors sometimes asked students to read the text in order

to correct their pronunciation. The tutors analyzed the implied meanings of the texts just like Chinese teachers did with the Chinese texts in class. And the students were often asked to paraphrase the texts and to translate them into Chinese (transd5:1-2).

There was also the 'Extensive Reading' course, where the tutor taught reading skills such as skimming, scanning, guessing the meaning of a word by the affixes and stems, etc. The tutor asked the students to do reading quizzes in class, so there was no need to pre-read anything before class. M2 thought skills like skimming and scanning very essential for the fast reading tasks in exams, and for preparation of exams, when there were a lot of materials to study during her undergraduate years (transd5:3).

According to M2, the 'Intensive Reading' course was the only course on which she spent much time after class. For the other English courses, she usually did reading shortly before the exams or before the essays were due, which was especially true while she was in her third and fourth years at the university, when she attended more social activities (transd5:4-5). Besides reading course books and materials assigned by tutors, she also read in English with a hope to improve her English proficiency in general. For example, she read magazines such as 'English Saloon', and 'English World', in which there were short articles about western cultures and customs, about famous singers or other public figures, little jokes, poems, and so on. The articles were all written by native speakers of English, from which she could learn nice words and expressions. 'Crazy English' was another magazine that she liked very much, each issue of which was always accompanied by audio tapes. She enjoyed listening to the music, excerpts from films, famous public addresses, poems, etc. in the tapes, and often played them as a background while doing other things (transd5:5). She read 'New Concept English' volume three and four, too. As for volume three, she actually listened to the tape and tried to write down every word she heard, as a way of preparing the 'dictation' section in

the ‘English Proficiency Test for English Majors Band Four’. She read volume four with an attempt to learn the texts by heart, which she thought could help her in writing. She also read volume four in a way to exercise her skill of translation—as she read, she translated every sentence (transd5:6). She read English novels too, as one of her tutors for ‘Intensive Reading’ course required them to. She read four simplified versions of novels every month and wrote reports<sup>16</sup> on what she read according to her tutor’s requirements (transd5:5). M2 commented that her extra reading in English was mostly for the purpose of improving her English reading, writing, and vocabulary; and that, these readings were after all more interesting and closer to real life, and consequently more attractive to her than textbooks (transd5:9).

Apart from the courses related to English Language and Literature, there were courses delivered in Chinese. Although she normally read the course books only before exams, there were a couple of courses, such as ‘Introduction to Law’, which interested her especially, so that she read the course materials before attending the lectures (transd5:5). Though reading was not one of her interests, she read quite often during her undergraduate years, the fourth year in particular, because after she compared herself with her friends, she felt an urgent need to broaden her vision and knowledge by reading (transd5:12). She read novels recommended by her friends, books by authors who interest her, magazines for university students, fashion magazines, and so on. Reading news online was an indispensable part of her daily life, and she also sometimes read online novels (transd5:11).

To sum up, similarly to E2, M2 was mainly raised by her grandparents, who did not encourage her to do extracurricular reading as long as she achieved good school results. Therefore, M2 always preferred social and outdoor activities to reading. Influenced by

---

<sup>16</sup> The reports should contain a biography of the author, the background for the writing of the book, a summary of the story, and a reflection on it (transd5:5).

her teachers and some friends, M2 started paying more attention to reading after she entered secondary school when she found her reading was more limited than some of her friends (transd4:3-4). Also like E2, reading had never been a very important part of M2's life.

M2 was a diligent student at school, especially for subjects that she liked (e.g. English as her favourite subject). She was also hardworking at university, spending most of her time on academic works in the first two years. During the third and fourth years, she was more attracted to social life but still managed to get some of her work done rather than put everything off until just before the deadlines or exams and also managed to read something in addition to the course books (transd5:4-5, 9).

#### **4.5.4 Summary of the Four Subjects—RQ 1**

Having retold all four subjects' past experiences of education and literacy in turn, I will now try to answer RQ 1 (*What were the main reading practices of the subjects before they came to the UK?*) by summarizing their reading practices in relation to each of the three stages of their education in China.

At primary school stage, only E1 took reading as a serious hobby, due to the influence of her father, who also loved reading. Reading was E1's main pastime and she was especially fond of literary works and read Chinese classics from a young age. She mainly read what her father bought for her and what was available in her father's collection. As a result she read more extensively than most of her peers, which made her feel that the Chinese lessons at school were very easy to handle. The other three subjects reported that they did not read much at this stage and preferred outdoor activities to reading. In E2 and M2's cases, it was mainly because their caretakers did not encourage them to read; whereas in M1's case, he did not want to read much even if his mother and sister urged him to. When they did read, E2 and M2 preferred fairytales and story books,

whereas M1 preferred collected compositions by pupils of a similar age group as a way of improving his writing and of learning about what others' lives were like. E2 and M2 also reported that they read the same sort of collected compositions by other pupils as M1 did, but only as a reference book when they had a writing task to fulfil.

At the secondary school stage, due to the huge pressure of school work and exam preparation, all four subjects reported that they had little time for extracurricular reading. They spent most of their time doing exercises for different subjects, including a lot of reading comprehension exercises in both Chinese and English. E1, E2 and M2 reported that they did light reading to relax their brains when they could afford the time, such as teen magazines, stories, cartoons, and so on. M1 developed an interest in reading sports news and also news in other areas during that period of time, which has remained as his habit since. The reason for that was, as he recalled, to be able to exchange information and knowledge among the group of his friends and classmates.

All subjects were studying English at that stage (with E2 and M1 starting English lessons at primary school). E1 reported that she seldom read in English in addition to school work, as she was too fond of reading in Chinese to develop an interest in reading in English. E2 did not read in English in addition to her school work either, because she did not do any extra school work apart from what the teachers required her to as a rule. M1 and M2, both considering English as their favourite subject at school, always sought opportunities to read in English, but mainly with a purpose of improving their English (e.g. to learn more new words, to read faster, to learn more grammar, etc.).

At the tertiary level, all subjects reported that they had a lot of time exploring whatever they would like to read in Chinese and/or English. E1 read even more widely now that she was not restricted to her father's collection. She touched upon politics, philosophy, and the like, in addition to literary works. She even read political writings

that were forbidden by the authorities from being circulated, because she believed that as a young student with independent judgement and outlook, she should not restrict herself only to readings that were approved by the authorities. M1 steadily developed his interest in reading at this stage. He started reading works by ancient Chinese philosophers and trying to connect the readings to his everyday life. Reading in Chinese for non-academic purposes increased in E2 and M2's cases, as they realized their limited general knowledge in comparison with some of their friends. In a sense, the reading was done more out of a need to assimilate themselves with people to whom they looked up, than out of a need to satisfy their personal interests. Or in other words, these data can be seen as indicating that it does not seem appropriate to consider reading as only residing in the private sphere of one's life. Instead, the activity of reading can be seen as capable of being influenced by one's social needs such as a desire to present oneself as a knowledgeable or learned person, a desire to be part of a certain peer group, a fear of being excluded from a conversation of a popular topic, etc., especially when one is not a real book lover. As for academic reading in Chinese, E1, E2 and M2 usually read course materials shortly before exams, unless they were especially interested in the courses; E2 (majoring in History) also read her textbooks as story books; M1 was the most diligent student among the four. He usually followed the tutors' reading requirements rather than postponed everything till shortly before the exams, and he even read extra materials in order to learn better.

As E1, M1 and M2 all majored in English, they needed to do quite a lot of academic reading in English. Most of their courses were related to the English language (reading, writing, listening, speaking, translation, interpreting, grammar, etc.), and literature. E1's attitude towards academic reading in English was similar to what she had towards academic reading in Chinese, i.e. she was unwilling to spend more time than necessary

on uninteresting subjects in order to pass them. M1 again always made effort to fulfil and go beyond tutors' reading requirements. Moreover, academic and non-academic reading was mingled together as he started to switch to the English versions of what he normally read in Chinese (such as news, sports, etc.). E2 and M2's reading in English at university continued to serve mainly the purpose of improving their English proficiency and especially for the preparation of exams (as at the secondary school level), rather than for information or pleasure.

In short, the summary above seems to indicate that, while similarities existed in various aspects of their reading practices, the subjects also all differed from each other in various ways in this respect (cf. Parry & Su, 1998). In what follows, I will pull all their "stories" together in order to reconstruct the activity system of the contexts in which the subjects' education and literacy experiences took place, in answer to RQ 2 and as a preparation for the discussion in the subsequent chapters of their current literacy practices in the AS of the masters' programmes at Lancaster University. As will be seen, many of the "background" features of the subjects' reading practices identified here can be seen to have an enduring existence in terms of their subsequent reading practices in the UK. As such, it will be possible to begin to see how the perspective used in this study can help to throw light on literacy practices – such as the way the past literacy history of the readers affects their current practices – in a way which more traditional research approaches tend to leave out of the picture.

## **4.6 The Past AS**

The summary of the four subjects' past experiences from an activity theory perspective which follows does not aim to generalize the activity system of the Chinese education system from the four cases, nor to capture every aspect of those activity systems due to the limitation of retrospective interviews, but to gain an overview of the



key features of the activity systems that the subjects once belonged to. I will take into account all three stages of education (i.e. primary, secondary, and tertiary) in the discussion of the components in the activity system, because firstly, they all contributed to the formation of the subjects' educational experiences in China, and secondly, the educational experiences at different stages as a whole will constitute the basis of the analysis of the subjects' literacy practices in the UK. In this way, I am making it possible for comparisons and contrasts to be made in the subsequent chapters between the past and current activity systems the subjects have been involved in, within the overall purpose of investigating what shapes the subjects' academic reading experiences.

#### 4.6.1 'Subject'

The 'subject' in the activity system consists of the four Chinese students—E1, E2, M1, and M2—at the starting point of their postgraduate studies at Lancaster University. As I have summarized the characteristics of each of the four students in the foregoing sections (see 4.2, 4.3, 4.4, and 4.5 above), here, I will only briefly mention again their self-perceptions of themselves as students, and their attitudes towards learning and towards reading, which, as will be seen, turned out to be crucial to their later academic reading experiences during their master's studies (see e.g., sections 6.4.1.1, 7.3.1.1, 8.3.1.1 below).

Among the four subjects, E1 was the most confident, who trusted and depended more on her own judgment than on the teachers', and hence did not bother to spend much time on the subjects that did not interest her. For this reason, she was the most careless among the four about her study at university<sup>17</sup>, i.e. she only spent time on

---

<sup>17</sup> At the primary and secondary level, students had no choice but to follow teachers' instructions in order to prepare for various exams. Not until they enter the university, do the students get some control over time allocation.

subjects in which she had some interest or the tutor of which delivered very good lectures; otherwise she only made minimum effort as to be adequate to pass the course assessment.

In contrast, E2 was the least confident in her academic abilities and tended to rely on teachers' instructions greatly. She viewed herself as average student and was satisfied with herself being average. As a result, she seldom made any initiatives in her study or did any extra work in addition to what was assigned by the teachers; she neither made extra effort for better results for subjects she liked, nor did she make less effort than what was required by the teachers for subjects she did not like.

M1 was probably the most diligent student among them all. He always tried to fulfil teachers' requirements for reading and other tasks and tried his best to study all subjects whether he liked them or not, even at university when there were very few high stakes exams to force him to study.

M2 was also diligent, though not as much as M1, in that she normally tried to fulfil tutors' requirements, and was willing to make extra effort for better achievement. Most noticeably, she made a lot of effort in trying to improve her English proficiency ever since she started learning English, by reading various extra materials and doing a lot of extra exercises.

As regards their attitudes to reading, E1 was interested in reading ever since she was very young and had always been interested in reading literary works. However, she never liked reading in English either for improving her English or for pleasure. M1 had also developed his interest in reading gradually, and was especially interested in reading news and things that would provide guidance for his everyday life. In contradistinction to E1, M1 was so fond of reading in English that he preferred to read in English whenever he had a choice between the Chinese and English versions. E2 and M2 read

more and more as they grew older because they realized their reading had been limited while they were younger. Though they read newspapers, magazines, and other things that interested them, reading did not seem to be a very important part of their lives. Or in other words, they would normally prefer some other forms of entertainment over reading. They read English mainly in order to improve their English proficiency rather than for pleasure or information.

#### 4.6.2 'Object'

It is difficult to talk precisely about the 'object' of three different stages of education at one time. Here, I am only trying to present a rough picture of the common 'object' of different stages and perhaps also some aspects that were peculiar to a certain stage, with special reference to the learning of Chinese and English.

##### 4.6.2.1 Primary and Secondary Education

According to the four subjects, teaching of Chinese and Chinese reading at school was very much stereotyped as well as exam-oriented<sup>18</sup> (transa1:3, 6, 12, transb3:7-9, transc1:13). Except in lower grades at primary school when the emphasis was on learning new Chinese characters, words and sentences (transa1:2, 4, transb3:5), Chinese lessons mainly aimed to teach students how to divide a text into several sections logically, to summarize main ideas of each paragraph and each section and the theme of the whole text, and to answer other types of comprehension questions. The primary reason why these things got taught in Chinese lessons was because they would be tested

---

<sup>18</sup>As E1 said in her interviews, "in my days, (teaching of Chinese) was mainly exam-oriented. Textbooks were used for decades without any change. The model of teaching remained mostly unchanged. In secondary school as in primary school, what we did in class was still old stuff like summarizing main ideas and themes. Teaching of Chinese reading in class was a kind of mechanical training of doing comprehension exercises—students were asked to read passages and to answer questions designed by imitating exam questions." 在我们那个年代的话还是以应试教育为主, 教的课文都是几十年, 可能课文可以不变的那种 transa1:3, 中国这个教学模式, 语文课基本上没什么变化。虽然是到了中学我们还是要总结段意, 写中心思想这样老八股的东西 transa1:6, 课内的阅读现在看来…都是一些怎么说呢…这种机械化的培养, …就课内大部分是一些练习题, 说白了。…给你整段整段的文章, 文章读了然后让你仿照高考, 或者仿照一些考试的例题给你出成题 transa1:12. (my interpolation).

in Chinese exams at different stages (transa1:6, 12, transb3:7-9, transc1:13-14). The same was true also for other subjects including English—teaching of English was very much influenced by exams. Although they started English lessons by learning simple dialogues for daily use, all four subjects reported that the main tasks in English lessons were learning new words, set phrases, sentence patterns and grammar, because the ultimate purpose of their learning was to get ready for the College Entrance Exams (transa1:14-17, transc1:21, transd4:7). E2 mentioned that English was the subject on which she spent the biggest portion of her time after class, and the time spent on learning English was basically dedicated to doing all kinds of English exercises, checking the answers and analyzing why she did some exercises wrong so as to avoid the same mistakes again (transb4:10). In other words, she seemed to consider learning English as almost equal to training herself to get all exercise questions and hence exam questions correct. The other three also reported doing piles and piles of English exercises and mock tests after class (transa1:10, 13, transb4:9, transc1:5-9, transd4:8-11). Such exercises all, more or less, bore resemblance to exam questions, and were intended to prepare the students for exams.

In short, the way Chinese was taught was generally similar in all four cases at both primary and secondary levels. Although how English was taught and learned may have differed according to the resources available<sup>19</sup>, the overall ‘object’ of teaching and learning at the secondary level was to get ready for the College Entrance Exam. The time they spent on English was mainly used to do all kinds of exercises for exam preparation, and whether they would read anything extra in English depended on the

---

<sup>19</sup> The east and south coastal areas are usually more developed than the inner areas, and therefore more resources may be available in the former, such as up-to-date textbooks, published materials in English, better qualified English teachers, etc.

availability of the materials and their personal interest<sup>20</sup>. On the whole, the primary and secondary education seemed to share one common ‘object’—getting prepared for exams at different levels and for the College Entrance Exams eventually; only that at the secondary level, education was even more exam-oriented than in primary schools—students were drowned in a sea of exercises in order to prepare for the College Entrance Exams. It seemed that the teachers and students were both aiming at achieving this ‘object’.

#### 4.6.2.2 Tertiary Education

At the tertiary level, ideally speaking and also as officially acknowledged by the Chinese Ministry of Education, the ‘object’ of higher education in China is to cultivate humanistic, creative and physically and mentally healthy human talents with upright moral sense and advanced specialized knowledge<sup>21</sup>. However, as the Vice-Minister of Education has pointed out, this ideal ‘object’ was neither widely recognized, nor put into daily practice<sup>22</sup>. Although it would be difficult to know how the teachers think about this ‘object’ from my interview data, it is quite clear that E1 and E2 were not likely to work at this ideal ‘object’. Take E1 as an example first. She did not take many courses very seriously if they were either not important or useful core courses, or the lectures were boring, or the courses were too easy or too difficult for her (transal:20, 22,

---

<sup>20</sup> Take E1 as an example. She reported that no authentic reading materials in English were available when she was at secondary school. And besides, she was not interested in reading in English at all since she was too fond of Chinese literature to also be interested in reading in English (transal:15).

<sup>21</sup>培养和造就大批掌握高科技和现代科学管理知识, 具有良好人文精神的有创新能力的人才, ...是 21 世纪中国大学的根本任务。The fundamental task for Chinese universities in the 21<sup>st</sup> century is to cultivate a large number of humanistic, creative and physically and mentally healthy human talents with upright moral sense, and advanced specialized knowledge (‘中国高等教育目标’ China.com.cn 中国网 2004 年 09 月 14 日 retrieved on 02/07/2005).

<sup>22</sup>大学生应具有“素质”的内涵包括: 思想道德素质、文化素质、业务素质、身体心理素质。... 21 世纪的高等教育在人才的培养上, 要强化“素质”的意识... 这一点还没有完全被人接受, 还没有形成高等教育战线广泛的实际行动... The ‘qualities’ that a university graduate should have include moral quality, cultural knowledge, subject knowledge, and physical and mental health. Higher education in the 21<sup>st</sup> century must emphasize the importance of these ‘qualities’ in the development of talents, which, however, is not widely acknowledged, nor widely exercised. (Vice Minister of the Ministry of Education of PR China: Zhou Yuanqing, 18/11/1999, Chinese Education Newspaper. 摘自 1999 年 11 月 18 日《中国教育报》, 教育部副部长 周远清 retrieved from the Internet on 02/07/2005).

23, 25)—for instance, she did not go to some classes, or she was doing something else in class instead of listening to the lecturers (transa1:20, 21); she did not study for some courses until a couple of weeks before the exams, and the way she studied for these courses was just to copy lecture notes from others and to learn by heart what might appear in the exams (transa1:22, 23). However, she did study some courses carefully because they were essential core courses, as she said, “you had to study these core courses of your subject area because you need to take the exams” (transa1:22). When she was really interested in certain courses, or the lectures were very enlightening and exciting, she would spend time on them very willingly (transa1:24-26).

In E2’s case, as a history student, during term time she read various history course books in the same way as she read novels because she was very interested in history and always saw history as stories, and toward the end of term, she learned by heart answers of possible exam questions in preparation for exams (transb4:11, 14, 15). For most other courses, she rarely or never read on them during term time. If the form of assessment was exams, she started trying to memorize whatever might be tested in the exams a couple of weeks before (transb4:15); if they were asked to write essays, she started searching and reading reference books when the deadline was approaching (transb4:16). In doing her writing tasks, she did not try very hard to do her best because she did not think it necessary to take all the trouble just to get a high mark (transb4:19). For instance, once she did not read any reference books before writing, and another time, she just read one book for an essay, though normally she would read three to four; and it usually took her two to three days to finish an essay of two to three thousand words (transb4:14-16).

From E1 and E2’s experiences of university studies, it seems that they did not care much about what they learned, how much they learned, or how well they learned. What

mattered was to get through the assessment of all subjects with minimal effort. Beyond that, they invested time and energy happily in whatever they were interested in. It was very likely that the exploration of personal interests would contribute to their overall development as a person. Yet the more obviously recognizable ‘object’ of E1 and E2’s from their point of view was to get their first degree for its own sake without much consideration of their personal development, which was absolutely different from the proposed official ‘object’ of Chinese higher education. It may not be difficult to understand why E1 and E2 had such an ‘object’ considering their education experiences throughout the years at primary and secondary schools<sup>23</sup> when the primary purpose of schooling was to prepare for various exams. And it may not be easy for them as new university students to realize that the purpose of their study at university could be and should be different now that they did not face anything like the College Entrance Exams.

Compared to E1 and E2, M1 and M2 were more concerned about their studies in that they were willing to invest time and energy in doing the reading and other tasks that their tutors assigned, and they were even doing extra tasks to improve their learning. M1, in particular, also made links between what he studied and his real life situation. For instance, after he studied some essays in classical literary Chinese by people like Confucius, Sun Zi<sup>24</sup>, and Mencius<sup>25</sup>, he tried to read more works by them and kept thinking about the messages conveyed in them and how they could be used to enlighten his real-world life (transc1:47). Since he chose to study English at university, he switched to English language websites for the news and other things that he read regularly so that he could be informed about the areas that he was interested in and to

---

<sup>23</sup> That is twelve years altogether.

<sup>24</sup> They were great Chinese thinkers of the Spring and Autumn Period (around 700-400BC).

<sup>25</sup> He was Confucius’ student—a great thinker of the Warring States Period (around 400-200BC).

fulfil his tutor's reading requirements (transc1:38-40). Though not as hard-working as M1 was, M2 was neither as unconcerned about her study as E1 and E2 were, considering all the extra reading she did for her study (see 4.5.3 above). There may still be gaps between the 'object' that M1 and M2 were working at and the officially stated 'object', but they were at least doing something more than just trying to get a degree with minimum effort.

### 4.6.3 'Mediating Artefacts'

At the primary and secondary levels, the most salient 'mediating artefacts' were textbooks and incredibly large number of exercise books and mock tests as all four of them mentioned in their interviews (transa1:13, transb4:5, 8, transc1:13-14, 21, transd3:5, transd4:5-7, 8-10); the form of assessment was always exams and exams only. At the tertiary level, although textbooks still prevailed, there were also various other forms of artefacts such as lecture handouts, library resources, reading lists, and so on (transa1:20, 24, transb4:14, 16, transc1:35-38, transd5:1-4, 7-9). For instance, M1 read news and other information that interested him in English websites very often, partly because of his tutor's reading requirements and partly because of his own interest (transc1:38, 40, 50-51). M2 read online news in Chinese regularly and sometimes online novels, and often used the Internet to search for reference materials when she wrote academic essays (transd5:7, 11). As for assessment, exams were still in a dominant position, but essays also became an indispensable part in the assessment system, especially for the final stage of most degree courses—dissertation (transa1:20-25, transb4:13-17, transc4:4-6, transd5:7-9).

Teacher's talk dominated the teaching sessions throughout the three levels of education according to the four subjects. This was especially the case at the primary and secondary levels, with probably one exception, i.e. M1's English lessons at primary



school, where the teacher only talked for about ten minutes and then the students would be doing all kinds of dialogues and role-plays. At the tertiary level, M1 mentioned that there were a couple of courses where the tutors let the students initiate discussions in class instead of the tutors giving lectures (transc1:27, 35). However, E1 did not mention any course with seminar or class discussion as a supplementary form of organizing the class, while E2 mentioned one course in which the tutor attempted to encourage students' discussion without much success as E2 and her classmates were not willing to discuss in class (transb4:15). E1's opinion about learning and knowledge may throw some light on the reason why some students do not like discussions in class: E1 thought she could gain much knowledge from lecturing if the tutor delivered really infectious and enlightening lectures, even though the tutors might not pay any attention to the students' reaction to his/her talk, and that was why she always preferred lecturing to discussions (transa1:25).

#### **4.6.4 'Community', 'Division of Labour', and 'Rule'**

In China, generally speaking, the lower level a school belongs to in the education system, the simpler the constitution of the 'community'. For example, at primary school and most junior high school, pupils were usually from the same neighbourhood<sup>26</sup> (transb3:3, 6). At the secondary level (especially senior high schools), students may come from different areas of the same city or even from other cities, especially when the school is a very good one or a boarding school, such as in E1's case. At the tertiary level, the students were usually from all over the country, which is particularly true for top universities. The students and teachers usually shared the same language—mandarin Chinese, and the same nationality.

---

<sup>26</sup> It is a guiding principle for primary and junior middle school to enrol pupils from nearby neighbouring areas, which is stipulated by Chinese laws and regulations.

In terms of ‘division of labour’, it was usually teachers who gave instructions and students who followed instructions (transa1:2, 14, and 15, transb3:4). According to E2, she followed teachers’ instructions only, and did not do any extra homework after school (transb3:14). Sometimes she even did less than the teachers’ requirements (transb4:3). At university, both E1 and E2 reported that they enjoyed spending time on things that interested them, and did not study uninteresting or unimportant subjects until just before exams or essay deadlines (also see 4.6.2 above). In short, they were unlikely to take the initiative to learn something unless they were really interested in it. In contrast, M1 and M2 took more responsibility and initiative in their study than E1 and E2 did at university, in that they were willing to make efforts in doing more than what the tutors required. It seemed to indicate that diligent students still exist at the tertiary level, who study willingly without external forces.

As far as ‘rule’ is concerned, under the exam-oriented education practices, different parties, including the administrators, teachers, and students, seemed to come to a consensus that what mattered most was to improve students’ exam scores especially in the College Entrance Exams. What the teachers did in class and what the students were asked to do in and after class all seemed to revolve around exams (transa1:7-9, 12, 14, 15, transb3:5, 9, 12, transb4:1, 3). After entering universities, an obvious change on E1 and E2’s part was that study was no longer the primary concern of theirs. Both E1 and E2 mentioned that they had a lot of time of their own, when they could do whatever they liked, unlike at secondary school when they had to do endless work to prepare for exams. M2 shifted her emphasis on study to social life since her third year at university. So at the tertiary level, the ‘rule’ seemed to be that as long as the students could make sure to get through the assessment of all subjects, the tutors did not seem to care much about how the students used their time. Take E1 as an example, she dealt with the ‘rule’

very well. Since exam was the most common form of assessment, the most important thing for her was to make sure that she got hold of the lecture notes from her classmates, or went to the sessions when the tutors were talking about the topics covered in the exams, and learned everything by heart before the exams. Apart from that, she could choose to skip whatever sessions that she was not interested in as long as the tutors would not easily be able notice her absence, not to read any boring textbooks except for studying for the exams, not to go to the library, and so on. The other three subjects also seemed to manage their own priorities and the assessment requirements.

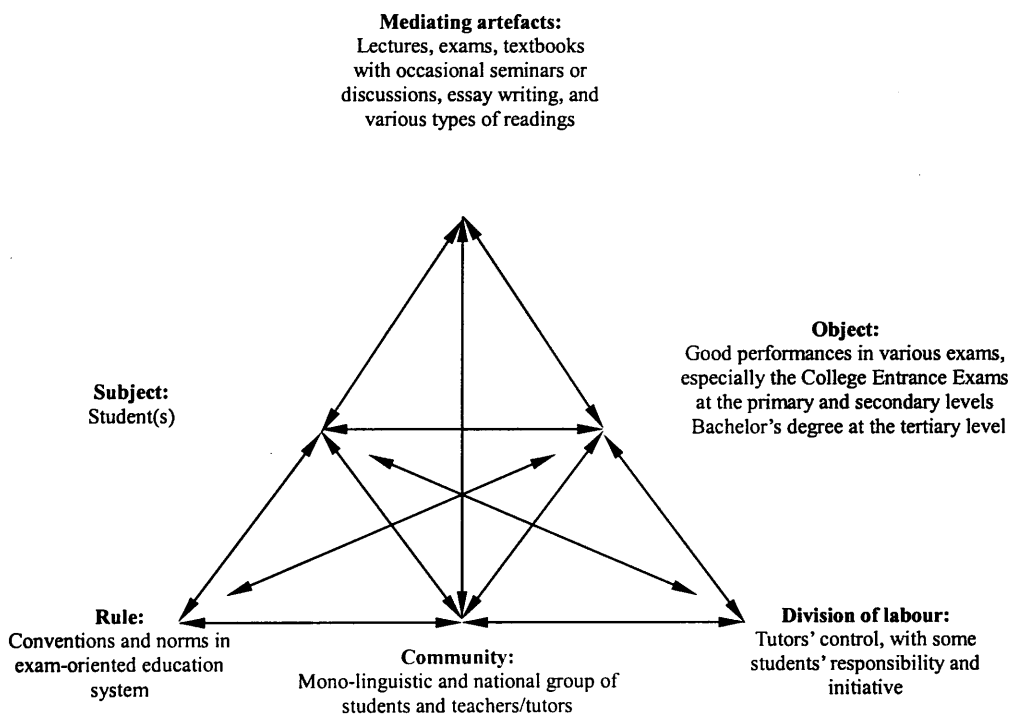

Figure 4.1 The activity system of Chinese education system at three levels.

Figure 4.1 above summarizes the six components of the activity system of the education system at three levels in China on the basis of the four cases this study is concerned with. In the following section, I will explore whether and how each component of the activity system played a role in the subjects' reading practices, in order to answer the RQ 2—*What aspects in the context (in terms of the activity system*

*model) have played what role in the shaping of the subjects' reading practices prior to their arrival in the UK?*

## **4.6.5 Roles of the Components in the Subjects' Reading Practices**

### **4.6.5.1 Family Factor—Pre-schooling Stage**

Before tapping into the components of the activity system of the Chinese education system, it may be worth mentioning the contribution of the family factor in the subjects' reading practices before they entered the formal school system, as the analysis so far indicated that the subjects' attitude towards reading seemed to take shape before they started formal schooling. E1's enthusiasm for reading Chinese literature was first developed as a result of her father's influence, and was growing steadily ever since. Her love for Chinese literature was so strong that she never developed any taste for reading in English. E2 and M2, on the contrary, did not like reading very much, and one important reason for that was their grandparents—their main caretakers—did not encourage them to read. M1's case was an exception, in that his mother encouraged him to read, but he still did not show interest in reading until he started secondary school. There were of course, other contributing factors, which will be discussed in due course. The family factor should still be acknowledged as one of the contributing factors, though it was not one of the components in the activity system.

### **4.6.5.2 The Role of the 'Object'**

The 'object' of the activity system at the primary and secondary levels was to get prepared for various exams and eventually the College Entrance Exams. To achieve this 'object', the students had to spend most of their time reading books related to school work and exams, and doing piles and piles of exercises. In this sense, the

'object' was a powerful factor that shaped the subjects' reading practices. In addition, the effect of the 'object' at the primary and secondary levels even extended to the tertiary level, which made some students (such as E1 and E2, see 4.6.2 above for details) unable to adjust to the ideal and official 'object' of the higher education, and which also influenced some students' reading practices at university (see sections 4.2.4, 4.3.4 above for details).

#### **4.6.5.3 The Role of the 'Community'**

The analysis of the four cases above seems to show that both teachers and peers (fellow students, friends, etc.) played an important role in the subjects' reading practices, especially in E2, M1 and M2's cases. As all three of them did not develop a habit/hobby of reading at home, they began to realize the need for extracurricular reading after their teachers reminded and encouraged them to do so, especially after they started learning to write compositions. Although not all students may follow the teachers' advice closely and start reading widely (such as E2), they all seemed to be influenced by their peers. For instance, E2 and M2 felt the real need for wider reading after they found that they read far less than their fellow students; M1 read about sports and current affairs so that he would not be left out of his friends' conversations. What they read might also very much depend on their friends' recommendation, or what their friends were reading or owning at the moment. Teachers may play another role in students' reading—by delivering interesting and enlightening talks, they aroused the students' interest in certain areas, which may last throughout the students' lifetime (both E2 and M2 were cases in point). Teachers might also discourage students from reading things that the teachers thought irrelevant to the school works or exams, which could be viewed as another effect of the 'object' of the activity system.

#### **4.6.5.4 The Role of the 'Rule' and 'Division of Labour'**

As the 'rule' was so closely related to the 'object', its role also seems to have been similar to that of the 'object's'. Therefore, I will not discuss it here again. With regard to the role of the 'division of labour', throughout the three stages of education, most reading materials (related to school or academic works) were assigned or recommended by the teachers/tutors. Some students might also take some initiative to search for their own references while writing essays or dissertations (all four subjects reported that they had done this). M1, as the most diligent student among the four, even took the trouble of searching extra readings in order to better understand the lectures. On the whole, it seemed that teachers/tutors took most responsibility in deciding what and how the students read, whereas some students were also willing to take some initiatives in this respect.

### **4.7 Conclusion**

This chapter has first of all presented a detailed picture of the four research subjects' experiences of learning and reading in Chinese and English, aimed at answering RQ 1 (*What were the main reading practices of the subjects before they came to the UK?*) (see 4.2.5, 4.3.5, 4.4.4, 4.5.4, and 4.6.1 above for summaries about the four subjects). Also, in order to attempt to answer RQ 2 (*What aspects in the context (in terms of the activity system model) have played what role in the shaping of the subjects' reading practices prior to their arrival in the UK?*), the education system in China has been analysed from an activity theory perspective, and the roles of the components in the AS explored to see whether and how they have contributed to the students' reading practices.

In general, the data have shown that, on the one hand, there were important individual differences in terms of the subjects' education and literacy experiences, i.e.

they had different attitudes towards and priority in terms of reading and learning, which led to differences in school and non-school based literacy practices; on the other hand, the role of reading in their prior education, i.e. their school-based literacy practices, especially reading in English, seemed a largely exam-oriented instrumental one. It is therefore plausible to assume that the combination of these two factors will affect the ways in which the subjects handle their academic reading practices in the UK setting. The relationship between the subjects' past education and literacy experiences and their later academic reading experiences in their subsequent study in the UK will therefore be explored in Chapters 5 to 8.

Chapter Five: The Activity Systems of the Two Masters' Programmes .....	143
5.1 Introduction .....	143
5.2 Life in a Small Town in the North of England .....	144
5.3 Reading Practices in General .....	147
5.3.1 E1's Case .....	148
5.3.1.1 Three Stages of Reading Practices in Term One .....	148
5.3.1.2 Construction of 'Object' .....	152
5.3.2 E2's Case .....	155
5.3.2.1 Pre-sessional Course .....	155
5.3.2.2 Term Time Reading .....	156
5.3.3 M1 and M2's Cases .....	160
5.3.3.1 Pre-sessional Course .....	160
5.3.3.2 Term Time Reading .....	161
5.3.4 Summary .....	164
5.4 The Masters' Programmes as Activity Systems (AS) .....	166
5.4.1 'Subject' .....	167
5.4.2 'Object' .....	169
5.4.3 'Mediating Artefacts' .....	172
5.4.4 'Community' .....	177
5.4.5 'Rule' .....	178
5.4.6 'Division of Labour' .....	180
5.4.7 Summary .....	182
5.5 Inner Conflicts in the AS .....	183
5.5.1 'Subject'—'Object' .....	183
5.5.2 'Subject'—'Mediating Artefacts' .....	183
5.5.3 'Subject'—'Community' .....	186
5.5.4 'Subject'—'Division of Labour' and 'Rule' .....	192
5.5.5 'Community'—'Object' .....	192
5.5.6 'Community'—'Rule' .....	193
5.6 Conclusion .....	194

## Chapter Five: The Activity Systems of the Two Masters' Programmes

### 5.1 Introduction

After exploring the activity system in which the subjects' reading activities were taking place in China, I now turn to a discussion of the activity system which the subjects became a part of after they started their masters' studies in the UK. This chapter mainly addresses RQ 3 (*What are the main kinds of academic reading practices which the students experience in a UK university setting?*) and RQ 4 (*What are the features of the activity system of a master's programme in a UK university in comparison with and in contrast to the activity system that the subjects used to belong to in China?*). As such, it attempts to explore the subjects' reading practices in general<sup>1</sup>

---

<sup>1</sup> In contrast to the reading for the purpose of writing assignments in particular which will be discussed in Chapters



in Lancaster University, and to analyse the two masters' programmes that the subjects were studying from an activity theory perspective. To do so, I will first of all briefly mention the subjects' "daily round" in the UK, then move on to a discussion of the reading practices that the subjects were experiencing during their stay in the UK, and finally, an analysis of the masters' programmes as activity systems. In addition to a discussion of each of the components of the AS, the latter also examines the relationships between some of them, in order to identify the contradictions and discontinuity between the Chinese AS and the Lancaster AS. The analysis of the AS of these two programmes will also form the basis for the analysis of the subjects' academic reading for assignment writing which will be provided in the subsequent three chapters.

## **5.2 Life in a Small Town in the North of England**

As argued in Chapter 2, following the NLS tradition, it is advisable to look at different aspects of people's lives in order to better understand their literacy practices, as literacy is often a part of everyday life, fulfilling various roles, and thus cannot be separated from it and be studied in isolation. For the Chinese students that this study is concerned with, literacy, and academic literacy in particular, was definitely an important part of their daily life. Therefore, a brief discussion of the students' lives in the UK in general may help us understand their academic reading practices.

With very different background and experiences, the four subjects came to a small town in the northwest of England (Lancaster) to study for their masters' degrees. E1 and E2, both coming from big cities in China, found life in Lancaster very quiet and boring—for example, shops closed very early in the evening<sup>2</sup> except a couple of

---

6, 7 and 8.

<sup>2</sup> Unlike in China, where shops usually close at around 10 pm.

supermarkets; eating out was too expensive; the primary form of entertainment, i.e. drinking in pubs, proved to be unpleasant as well as expensive (personal communications with E1 and E2, October, December, 2004). In contrast, M1 and M2, who also studied in universities in big cities in China though originally coming from what are called medium-sized cities in China<sup>3</sup>, did not complain about the 'boring life' in Lancaster as E1 and E2 did. The only impression I have got from their interviews in this respect was 'what a busy life they were leading' studying in the MSc. in Management programme. M2 reported that:

I have no time for anything other than reading materials related to the courses. ... Except for going to classes, I spend almost all my time reading course books till late at night, like two or three o'clock, every day. Even so, I could not always finish reading. ... We have case studies to do every day. ... I will finish doing case studies ... even if I have to stay up till four o'clock in the morning ... because I don't want to be the one who does not contribute to the group work. ... I would prefer to go to sleep whenever I have spare time...(transd1:10-12).

E1 pointed out that the biggest difference of all from the life in China was the language. Almost everything that came into sight in public places was in English—road signs, posters, advertisements, newspapers, magazines, books, food labels, etc. Even E1, M1 and M2, all of whom studied English language for their first degree, still complained that they had difficulty in understanding and communicating with local people (e.g. shop assistants, fellow students, lecturers, etc.) (transc2:14, transd2:5). Nevertheless, on the whole, despite living in an English-speaking environment, and studying in the medium of English, they reported that they maintained a mother tongue-based social 'world'. For instance, most of their friends were Chinese; they preferred to cook Chinese meals whenever they could afford the time for cooking; they (except M1<sup>4</sup>) preferred to browse Chinese websites for news, novels, music, etc., and would rather watch Chinese or sometimes Korean and Japanese movies and TV serials than hang out in pubs. However, the differences and inconvenience that they felt in life

---

<sup>3</sup> M2 had also once lived in a small town when she was very young.

<sup>4</sup> The reason for this has been explained in section 4.4 above, and will also be discussed in section 5.3 below.

did not seem important compared to the main purpose of their stay here, i.e. to make the most out of the masters' programmes that they were doing, for which they have paid such high tuition fees (transb1:12, transd1:11).

Yet they still would like to be closer to the local life and to have more opportunities to find part-time jobs for money to travel around, so E1 and E2 moved from campus accommodation to town shortly after the beginning of the first term, which also saved them a substantial amount of money on accommodation (personal communications with E1 and E2, October 2004). At the beginning, M2 had also thought about getting a part-time job so that she could have more contact with the society here. After all, she may not have much chance to live abroad after her graduation (transd1:1). But she did not manage to get a job since she seldom had time to look for one seriously. M1 had not mentioned any intention of having a part-time job. But a big fan of Manchester United and of football games in general, he took the advantage of living near Manchester and became a member of a certain club for Manchester United so that he was entitled to get very cheap tickets for the games played in the home stadium for Manchester United, which I think may be his way of getting contact with the local society (transc5:3).

E2, M1 and M2 had all attended a four-week pre-sessional summer course before they started their masters' studies. M1 and M2 thought the writing classes were very useful in teaching them to avoid making claims without support or evidence, to organize the essay, to be critical about the readings, to do the referencing properly, etc. (transc2:1, 4-5, transd1:1-3, 8). E2 felt the course beneficial more psychologically than linguistically. It mainly helped her adjust to the new living as well as academic environment in the UK, and offered her opportunity to make Chinese friends to ease her loneliness and homesickness. Otherwise she could not start her new life so smoothly, since she was not a flexible person who got used to new things easily (transb1:1, 2).

Feeling similarly, M2 commented that “the course helped me get used to the teaching methods here very quickly and informed me of some thoughts of the tutors here, which put me in a far better position than if I had started the formal programme right away (transd1:1)”. In addition to the benefits for her academic study, M2 also found that the four-week course provided her with the time to get herself adjusted to living on her own. During that time, she found herself very busy every day—learning to cook, buying groceries and other things to settle herself down, dealing with bank accounts and police registration, getting used to the life style here, and so on (transd1:8, 10).

Life in the UK as experienced by the four subjects and summarized above turned out to provide useful background for the discussion of the subjects' academic reading experiences to be presented in the subsequent chapters. It seemed to indicate that they were encountered with an environment (academically and non-academically) where there were unfamiliar and new elements, such as the language in use, the educational culture, the pressure of handling life alone abroad and coping with academic studies in a foreign country, which might take them some time to get used to and might affect their academic studies to a certain extent. Equally important to our understanding of their academic reading for the purpose of writing assignments if not more so, was the subjects' reading and academic reading practices in general, which I will now turn to discuss in the following section.

### **5.3 Reading Practices in General**

In this part, I will mainly explore the main kinds of academic reading practices that the subjects experienced, and also briefly their non-academic reading practices in answer to the RQ 3. I will discuss each subject in turn and summarize all four cases in the end. In so doing, I am making preparation for the discussion of the AS in 5.4 below.

### 5.3.1 E1's Case

In what follows, I use the first term as an example to examine E1's reading practices, and then I briefly sum up the analysis by talking about the construction of the 'object' of her reading activities.

#### 5.3.1.1 *Three Stages of Reading Practices in Term One*

During the first term, E1's reading practices kept changing over time, as the discussion below will show. At the beginning of the term, E1 tried to do the pre-reading<sup>5</sup> that the tutors asked the students to prepare. There were two core modules in that term—'Teaching, Learning and Assessment' (TLA) and 'Introduction to Educational Research' (IER) (transa1:30). There was a main course book for the IER module, so the pre-readings were usually book chapters or sometimes book chapters and articles (see appendix 7 for module outline). As E1 "has never done any serious academic research before" (transa2:18), she "thinks this module useful as an introduction to research" (transa4:1). However, she found the main course book, especially the part on philosophy in methodology, very difficult to understand and "full of abstract terms and concepts" (transa2:16). So she found herself some easier books on similar topics, which are designed for "new undergraduates or freshmen who have no experience in doing research and whose knowledge is not very sophisticated" (transa2:18), thus also suitable for her. These books were not in the reading list provided by the tutors, and she got them accidentally while she was looking for another recommended book on the same library shelf (transa2:18). The tutors of the TLA module managed to give "the students a reader pack at the very beginning of the course" (transst1:2). From the interview with a TLA module lecturer and by looking at the readings, I found that most

---

<sup>5</sup> Pre-reading tasks refer to readings that the tutors ask the students to prepare before attending the teaching sessions.

of the readings were articles with a little bit of theory concerning teaching and learning and a research study applying the theory. Because E1 did not have much knowledge of educational theories (transa1:31), she found the readings difficult:

我觉得这个难度蛮难的, 理论性特别强, 而且单词特别多, 有些东西你是看不懂的, 例如说什么…ZPDtheory 啊, Vygotsky 很有名的一个理论对吧, 那么象这些东西, 就说你看了以后, 我也不太明白。不光是有些生词, 就是不光是认识上的, 生词, 还有些甚至是意思, 整句意思, 你单词都明白, 你整句串在一起意思不明白。一些专有名词, 所谓的 ZPD 啊, 或者说什么之类的专有名词…

I found them (the readings) quite difficult—very theoretical and full of new words. You just cannot understand some bits, such as ... ZPD theory, one of Vygotsky's most famous concept. Even after I read it, I can't understand. ... It's not only new words, ... but also meaning of the whole sentence. Sometimes, you know every single word, but you cannot understand the whole sentence, or the whole phrase such as ZPD. (transa1:33)

Though she could not understand the readings very well, she was not worried too much, as she said, "I think the tutor will talk about this anyway in the session. ... I can't understand the theories even if I read it, so I just wait for the tutor to tell me (我想想老师反正也会要讲, 到时候, 我想想看一遍, 尤其前面理论反正看了看不懂, 就等着她讲。Transa1:34)". However, she found that the lectures did not help her in a way that she had expected, and she preferred Chinese tutors' way of teaching, which is evident in the following quote:

讲课其实我倒觉得对我帮助不是很大, 不太大。…我感觉就不象国内老师, 可能教学方法不一样, …象国内老师肯定会给我们灌输, …让你一下就那么灌到你脑子里去。…这边老师…讲得很零碎…不系统

Lectures don't help me much. (The tutors here) are not like those in China. Maybe (they have) different ways of teaching. They are not like tutors in China who pour things right into your brain. Tutors here ... don't give you systematic knowledge (transa1:36-37, my interpolation).

In order to understand these theories, E1 tried to find a way out by locating resources written in Chinese:

我会上网去查中文的 Vygotsky 的理论。我会查他和 Piaget 的理论, 我一看了就会懂很多。... 例如说你常常这个叫 ZPD 这样的概念对吧, 每个单词我都能认识, 但是我把它搁在一起我都不知道怎么翻译, 如果你让我翻译成中文, 但是我如果看见中文我就更能形象的理解它。

I'll search the Internet for the Chinese versions of Vygotskian theories, his and Piaget's theories, and I understand much more after I read them. ... For example, the concept of ZPD. I know every word, but I don't know how to translate the term while the three words are put together. But if I can read the Chinese version, I can understand it better. (transa1:33-35)

It seemed that, at the beginning of the term, E1 took pre-reading tasks quite seriously and tried different ways in order to understand better what she read. Personal communications with her during that period (October 2004) indicated that she was very

concerned about her first assignment, which was a research proposal. She talked with me several times about possible topics for this proposal, which she hoped could be developed into her final dissertation. Her reading practices well reflected her concerns:

过去的一天当中，看了一篇 dissertation，一篇关于 international student, international higher education 的一些，因为我现在想做这方面，因为我到这边来，现在我要写 proposal 或者是写 dissertation 的论题，我是比较感，这方面感兴趣，就是对一些，外国的学生，就是说中国的，或者说广泛一些叫 international student 那么到了英国这边，…那么很多人过来，我就对这个话题比较感兴趣。其实涉及到一些…这种叫什么 culture shock 这样的一种，到这边的不适应性这方面的。…现在我方向还没有确定，刚刚开始，就是具体往哪方面写我还不确定，但我主要想写这些外国学生到英国面临的一些问题。尤其是在高等教育啦，主要是在 post 这个阶段。因为我自己也是刚过来的，所以我对这方面，由于我自己很有感触，所以我对这方面，很有兴趣，想做。…我现在，还要刚入门。我还借了一本 Collins 的 The Essential Skill in Research 就说是研究的基本方法，不光是教育的，针对所有的，就说研究的入门书籍。主要现在在看这两本书。还有的就是看我感兴趣这方面的，我在网上查到了好几篇…关于 international education 的这方面的文章，国际教育方面的文章，和一些关于中国教育现状的 higher education 方面的一些文章。都是英语的。然后因为我想，趁我在研究上，先现在没有方向的情况下，想先看看研究方法，理论熟了以后，然后再多阅读一些东西，扩展一下知识面，然后再确定以后怎么写。对，这是我，我现在的一些阅读。

In the past twenty-four hours ... I read a dissertation on international students, or international higher education. I'd like to do (research) in this respect, because I came here ... Now I need to write a proposal, or choose a topic for my dissertation. What I'm interested in is something related to overseas students, Chinese students, or in a broader sense, international students who came to the UK. ... A lot of people come to study in the UK. So I'm interested in this topic, which involves something like a culture shock, or inadaptability to the new environment. ... I have no clear direction now. I've only started, so I don't know what exactly I am going to write about. My main focus will be the problems facing students coming to study in the UK higher education, at the postgraduate level in particular. I, myself, have just arrived in the UK recently, and have experience in this respect, so I'm interested in it and would like to do (research) on it. ... I am a beginner (in research). I've also borrowed a book 'The Essential Skill in Research' published by Collins. It's not only for educational research, but an introduction to basic research methods in general. I'm reading these two books (on research methods) now. In addition, I'm reading the area of my interest, i.e. international education. I've searched from the Internet several articles on this topic, and also articles on the current situations of Chinese higher education, all written in English. Since I have no specific direction of research at the moment, I am reading on research methods to familiarize myself with theories, and then broaden the range of readings, before I could decide on what to write about. So, that's the reading that I'm doing now. (Transal:27-28, my interpolation).

The research proposal was her first assignment and she had no experience of doing any research. So she put much effort in it in order to make sure she got it right. Besides, if she could write a proposal on a topic that she could base her dissertation on, that will save her much time and trouble when the time came for her to write the dissertation. And she had quite clear and natural justification for the area of her interest—relevance to her own personal situation, which may help keep her motivated during her research.

It also shows that she was able to use different sources to get reading materials—tutors' reading list, library, online resources, etc.

As she got more and more engaged in her first assignment, she tended to only do pre-reading for the IER module which was directly relevant to her assignment. As she mentioned in an interview:

我做了 questionnaire design 那部分...上课之前看的, ...当时有一节课是专门在讲 questionnaire design. ...因为我当时知道我决定我想用 questionnaire 嘛, 所以我就那堂课前特别, 比较细心的看过了就已经。...课前预习...我看得比较少, 我觉得没用。对我写作业一点帮助都没有。

I did (reading) on the part of 'questionnaire design' ... before the session. ... There was a session on questionnaire design. Because I knew I was going to use questionnaire (in my assignment) at that time, I did the pre-reading beforehand very carefully. ... I seldom do (other) pre-reading because it won't help my assignment at all (transa2:16, 30, my interpolation).

Whereas for the TLA module, she seldom did the pre-reading after the first couple of weeks, because:

我不喜欢, ...我觉得, 而且我们也没用。它主要讲的是...初中小学的, 而且就是相对英国这种教学环境的

I don't like it. ... And I don't think it useful to us. It mainly concerns about primary and lower secondary education in British educational system (transa4:1).

She came from a background of Chinese higher education—teaching English to college students, thus found the module quite irrelevant to her teaching situation, though one of the TLA module lecturers thought students should be able to find something useful in this module even if the teaching-learning situation may be different, as she remarked:

What they are not recognizing is that, if you are talking about teaching and learning, you are talking about some basic principles about how people learn, and so you can apply those principles to any learning situation. So it doesn't matter kind of ... (what) context you are looking at, you can still actually draw these things out (transst1:11).

Apart from the perceived relevance of the modules to her own situation and needs, another cause of E1's differentiated treatment of the pre-readings for the two modules may be the time when the assignments were due—assignment 1 of the IRE module was due in week six term one and assignment 2 on the first day of term two, whereas the two assignments for the TLA module were not due until week seven in term two. When the time was limited, E1 tended to prioritize reading for writing assignment. After she



submitted the first assignment at the end of week six, she allowed herself a break in reading—forgetting about academic reading for a while. And meanwhile she borrowed some books on SPSS, which she would need to read when she was doing her next assignment during Christmas holiday (personal communications with E1, December 2004).

To sum up, there seemed to be basically three stages of different reading practices in the first term: at the beginning, E1 did most of the pre-readings, and tried various ways of finding other reading materials to help her understand the pre-readings. As she became more and more engaged in doing her first assignment, she focused on readings related to the assignment only, and ignoring other readings because of either lack of time and/or lack of interest. And finally, after she submitted the assignment, she had a break when she rarely read anything academic before she started doing her next assignment.

Non-academic reading did not seem to constitute an important part of the readings E1 did every day. Whenever she did read for non-academic purposes, she read in Chinese, as she never had much interest in reading in English. Chinese literary works remained her favourite choice and she also browsed news in some Chinese websites.

### **5.3.1.2 Construction of 'Object'**

From the analysis above, the 'object' of the activity of reading seemed to be shaped and reshaped throughout the three stages of reading practices during the first term. At first, E1 was trying to do all the assigned pre-reading tasks. Both research methodology and educational theories were new to her and she was eager to learn. So when she found the pre-reading materials difficult to understand, she tried various ways of finding easier readings to help improve her understanding. On the face of it, she was aiming to learn, which was what the tutors would like the students to do. A closer look at what she

was actually working at reveals that there were conflicts between E1's 'object' and that of the tutors'. E1 only wanted to understand the theories and concepts in the areas of education and educational research. Therefore, she preferred to read easy and basic books on those topics and best of all—things written in Chinese. She preferred the Chinese tutors' way of teaching, where the knowledge seemed to be “poured into the student's brain” (transa1:36). Whereas from the tutors' point of view, the ideal 'object' of the activity of reading was to generate thoughts on the basis of the readings. That was a key criterion for choosing reading, as was evident in the following part of data from tutor interviews: “you try to pick something that's going to *create argument that's going to make the students think*. I don't pick it because I necessarily think it's a central piece of work, or has anything amazing to say necessarily. ... I don't pick something because it's classic (transt1:5, emphasis added)”. And tutors would like the students to “tak[e] a critical approach to the reading as well, not [to] tak[e] it at the face value (transst2:3)”. So, there appeared an obvious mismatch between E1's 'object' of reading and that of the tutors'.

At the second stage, where E1 was more and more engaged in her first assignment, her reading was mostly serving only one purpose—to enable her to write her assignment. She stopped doing most pre-reading tasks partly because of lack of time, and partly because of loss of interest in the TLA module, whose assignments were not due until later. The 'object' of the activity evolved from narrowing down the topic of the imaginary research, to finding justification for and contextualizing her research, to structuring the research proposal, to finally working out what to put in each section of the proposal. This process of reading for writing the assignment will be discussed in Chapter 6. At this stage, the 'object' of E1's activity of reading moved further away from the tutors' expected 'object' of students' reading (mentioned in the previous

paragraph). One may argue that during the course of writing an assignment, students were also learning something that tutors would like them to learn, through all the readings they had done, with which I absolutely agree. Just as one of the tutors of the IRE module said, “the aim of the assignment is to give some demonstrable evidence that people have learned to apply a range of research methods (transst3:8)”. However, in one research proposal, E1 could not possibly apply all the methods that have been discussed in this module. And as a matter of fact, E1 only used questionnaire as the means of data collection. Therefore, by focusing on reading what was useful for her writing, E1 virtually ignored the reading and learning of other contents that had been taught in the module, as well as what had been discussed in the TLA module. As for the last stage, E1 almost suspended all her academic reading, thus I will not discuss the construction of ‘object’ for this stage.

The discussion of ‘object’ seems to reveal that at a stage as early as a couple of weeks after the beginning of the first term, E1 had already decided to invest most of her effort on the completion of assessed work, and to be less concerned about what and how well she actually learned in each module or about meeting tutors’ expectation of reading and learning tasks. Interviews and personal communications with other students in the MA in Education programme showed that most of them came to the realization of the importance and necessity of putting the fulfilment of assessed work in the first place at a certain point of time during the course of their studies. The reasons for the students to do so may vary from person to person, and there may also be common ground among them. A full discussion of this aspect will be carried out in Chapter 6. What seems obvious here is that students and tutors may be working at rather different (or sometimes even contradictory) ‘object’, which may cause trouble between the two parties in terms of mutual understanding and effective use of the time and resources.

There will be a summary in section 5.3.4 below to bring out how the subjects' reading practices in general may help me explore the current AS of their academic studies and their current reading practices. Now I will turn to E2's case.

### 5.3.2 E2's Case

#### 5.3.2.1 Pre-sessional Course

Unlike E1, E2 arrived a month earlier before the academic year started to attend a pre-sessional study skills course because her IELTS score was below the official requirement. Yet she thought she would still like to take the course even if she had passed the language test because of her poor spoken English (transb1:1). Therefore the discussion of her reading started from when she was having the pre-sessional course. She reported that the most important function of this course was to speed up the process of her adjustment to the new living and academic contexts, since she was normally very slow in getting used to a new environment (transb1:1-2) (also see section 5.2 above). In addition, the course helped her develop the habit of note-taking while reading—a habit she kept ever since then (阅读方面啊, 就是教我 taking notes, 做笔记。Transb1:2). She did not take notes while reading before, because

以前因为读英语嘛, 以前英语又不是英语专业的咯, 所以只是考四六级啊, 然后只回答问题划出来。然后看中文书嘛, 做笔记哦我觉得好像也不太做的吧。因为这里做, 看英文就是你看完一段, 你一定要把它的主要它讲什么写在旁边或者划出来, 否则等于白看。

I was not a student in English department. When I studied English before, I only wanted to pass the CET-4 and CET-6<sup>6</sup>, so reading just meant to find the answers to the questions in the texts. While reading Chinese, I did not take notes, either. But here while reading English, I have to underline or note down in the margin the main ideas of each paragraph, otherwise it is like as if I have not read anything (transb1:2).

Besides, reading with a critical view was another point emphasized by the tutors here. E2 admitted that without such reminder, she would not have paid any attention in this respect. In terms of writing, the most rewarding thing was to learn about the

---

<sup>6</sup> College English test band 4 is taken by all university students in China in order to get a bachelor's degree; college English test band 6 is not compulsory but would be a plus if one passes it.

referencing system, which was totally different from what she knew in China. As she said, “although the course did not teach you everything about referencing, at least you are not absolutely ignorant about it (transb1:2)”. Besides reading the materials assigned by the tutors, E2 also browsed the Internet for news and as a way of entertainment. She felt that she was kept quite busy, probably because she had to adjust herself to the new living environment (transb1:11).

### **5.3.2.2 Term Time Reading**

Take the first term as an example, again. E2 took pre-reading tasks very seriously, as she said “I will definitely do the readings when the tutors give us hard copies<sup>7</sup>. If the tutors only set tasks in the handbook, I will most likely read them unless I am really occupied with something else and the topic does not interest me at all (transb1:7)”. By the time I did the first interview with her around half term, Term 1, there was only one occasion when she did not do the pre-reading (ibid). The reason for doing pre-reading was, according to E2, “firstly, we ought to do what the tutors tell us to do. Secondly, my English is far from good. If I don’t prepare the reading, I would not be able to follow the lectures well. If I have a rough idea of the readings, I could at least recognize something in the lectures. That’s why I’ll do most of the pre-reading tasks (Transb1:8)’. Even when she was busy writing her IER first assignment, she still kept doing her pre-reading (transb2:13)”.

Apart from the pre-reading, she mainly read for doing coursework. She did not read anything from the further reading list because for one thing, there were more readings than she could handle—if it took her four to five hours to read one paper, it may take her weeks to read one book (transb1:7). For another, she did not know whether and how

---

<sup>7</sup> For the TLA module, the tutors gave out a reader pack with all pre-reading tasks for the whole term.

useful the reading would be, nor did she have a clear purpose of reading, which might make her reading ineffective (transb1:7). This echoed with one of her tutors, who commented in an interview that

Very often when students read, unless they are reading for a purpose, with a very clear question that they are trying to answer, then they actually find it quite difficult to read. They don't necessarily retain very much. And that I would say that's true to me, as well. ...I need to read for a purpose. (Transst1:3).

While doing pre-reading, she kept the habit of making notes which she developed during the pre-sessional course. She also underlined and marked the texts, but that only was not enough to help her understand the texts. As she put it, "I make notes every time when I read, because marking and underlining a text does not provide you with the outline of the whole text. The notes you make show you the outline and general ideas of the text (transb1:4)". She also commented that "as foreigners, we cannot read English as well as the mother tongue—Chinese. We have to catch the essence (of what we read and note it down) so that we don't waste any time in reading everything again when we look back at the same texts (transb1:5, my interpolation)".

She usually did pre-reading very carefully and noted down quite a few things that she thought important because the tutors may not mention everything important from the texts during the teaching sessions—the lectures were usually more concise and brief (transb1:6, 8). Another reason for such close reading was that only in this way could she understand well what she read. She found that scanning did not help her make sense of what she was reading (transb1:3). She did not use a dictionary very often, and only consulted it when a new word seriously hindered her understanding (transb1:4, 5). The problem was, sometimes even if she knew every word, she still could not understand the text, which was exactly what E1 sometimes complained about (see section 5.3.1.1 above). E2 also found that even British students had difficulty understanding some texts, which showed that sometimes it was not the language but the concept that was difficult (transb1:9, 10). In general, she found theories difficult to read, but with

examples, they would become easier to understand (transb1:3); sometimes she found the title of some articles confusing (transb1:8).

The majority of the reading she did was academic reading in English, such as pre-reading and reading for coursework. Only occasionally when she was really bored did she browse Chinese websites for news and entertainment. According to her, her primary duty here was to study, so she should concentrate on it. Otherwise the high tuition fees that her mother paid would be wasted (transb1:11, 12). She also tried to read English newspapers not in order to learn about news but to learn new words, as she found she could learn many more new words in newspapers than in academic articles (transb1:11). When she first arrived, she read labels and instructions when she bought something new in order to be able to use it (ibid). She sometimes watched English movies and TV series, hoping to improve her English listening (transb1:12).

To sum up, unlike E1, E2 almost always did pre-reading tasks despite the fact that she may not be interested in the topics. Nor did she give up pre-reading when the texts were difficult, or when she was busy with her coursework. On the other hand, she did not do any extra reading from the further reading lists, either. This was understandable considering her previous experience of schooling: as an average student, she followed teachers' instructions closely—she never did any less than what teachers said, nor did she do any extra work beyond that<sup>8</sup>. E2's practices reveal to me that in a broad sense, the 'object' of her reading was learning in general rather than for assessment. However, she was playing a rather passive role in her reading in that she seldom made decisions for herself as for what to read<sup>9</sup>. She considered it her duty as a student to read what the tutors asked her to in preparation for a session, no matter how difficult or boring the readings may be, or whether they may be useful or relevant in the future. This may have

---

<sup>8</sup> See 4.3.2 above for details.

<sup>9</sup> Reading for writing assignments is not included here.

something to do with her self-image as an average student, who needs teachers' guidance to feel safe and certain about learning, and who does not aim to excel among the whole group with extra effort.

From the way she took notes while doing academic reading, i.e. writing down main ideas and/or outlines in the margin or in blank papers (transb1:2), the more specific 'object' of E2's academic reading seemed to be understanding the main ideas of the readings, which was similar to E1's 'object' at the first stage (see 5.3.1.2 above for details). The difference between E1 and E2 lay in that E1's 'object' of reading shifted when other priorities arose, whereas E2 kept this 'object' throughout the first term with some other emergent 'object'(s) at different times<sup>10</sup>. As also discussed in 5.3.1.2 above, this 'object' of E2's did not match what the tutors expected the students to do with the readings. The tutors would like the students to develop their own thoughts or arguments on the basis of readings (transst1:5). Some assignments that were based on particular readings clearly required the students to review the papers critically, which meant not only to understand, but also to form arguments about the readings (see appendix 12). Such mismatch in the 'object' of reading seemed to lead to some problems while the students were doing some of the assignments, which will be discussed in Chapters 6, 7 and 8.

Besides academic reading in English, reading for pleasure in Chinese, and reading for information both in English<sup>11</sup> and Chinese<sup>12</sup>, E2 also read English newspapers. The purpose was not to learn about news, as she could listen to BBC or browse Chinese websites for news. By reading newspapers, she could encounter more varieties of English words than by reading academic papers. She only bought one newspaper and

---

<sup>10</sup> These other 'object(s)' will be discussed in Chapters 6 and 7.

<sup>11</sup> Such as manuals, labels, etc.

<sup>12</sup> Such as news.



found that she could keep reading it because there were so many articles on it (Transb1:11). The 'object' of reading English newspaper was thus to learn the English language better or to know more about the language. The reason why she had this 'object' may lie in the fact that she did not specialize in English during her undergraduate years so she thought it necessary to improve her English, though she thought her English was good as a history student (transb4:23). Another reason may be her IELTS score being under the normal university requirements, which made her think that her English needed improvement<sup>13</sup>.

E1 and E2's cases both seem to indicate that they largely kept their usual reading practices as before they came to the UK; in E2's case, she also developed some new practices to accommodate the new context. Next I will turn to the two subjects in the MSc. in Management programme—M1 and M2.

### **5.3.3 M1 and M2's Cases**

#### **5.3.3.1 Pre-sessional Course**

Like E2, M1 and M2 both attended the four-week pre-sessional study skills course. During that time, they mainly read materials given by the tutors, and sometimes searched other reading materials in order to do the presentation tasks. Occasionally, M2 also went to the library to read journals related to business management as recommended by her tutors, and read some local English newspapers. Similar to E2, M2 also felt that making notes and summaries while reading helped her understand the readings, and thus she tried to do so later on. They did not manage to read much in addition to the tutors' requirements as they found the time passed extremely quickly. It seemed that getting themselves used to living and studying in a foreign country did

---

<sup>13</sup> She thought her spoken English quite poor, which could be the primary cause for her low IELTS score (transb1:1). Besides reading English newspaper, she also watched English TV programmes in order to improve her listening (transb1:12).

take much time (see E2 and M2's comments in sections 5.2, 5.3.2.1 above).

### **5.3.3.2 Term Time Reading**

Take the first term for example, again. They had four compulsory modules<sup>14</sup> and one elective module, which kept them very busy. According to M2, she spent almost all the time doing reading for various courses except for going to classes, and sleep, but still could not finish all the pre-reading tasks. M1 also felt great time pressure while doing the pre-reading tasks, but he seemed to be better at time-management than M2 in that he tried harder to and usually did manage to preview all the contents before attending lectures, because he thought it a waste of time sitting in a class without previewing the relevant contents (transc2:7-9). M1 and M2 seemed to approach their study and reading tasks differently in one way or another.

M1, as just mentioned in the previous paragraph, tried and usually managed to do all the pre-reading tasks as the tutors required, except for one module, whose reading for one session could go up to three chapters (transc2:9). His priority was the pre-readings for the 'Finance' module, which he "would definitely finish even if that would leave no time for him to sleep, because the tutor was so 'cruel' as to ask each individual student to answer some questions in each session for sure" (transc2:9).

Whenever he read or studied something, he was working at understanding, by which he meant his ability to apply what he learned from the courses and books to some real life situations. For example, he thought he understood 'Finance' the best among all the modules in the first term because when he learned something, such as 'in-flow' and 'out-flow', he could try it out when he went shopping in Sainsbury's, and some of his course mates even used the knowledge they learned from this course to decide which

---

<sup>14</sup> They were 'Learning to Manage', 'Economics for Managers', 'Finance', and 'Operations Management'.

bank they should use (transc2:10). On the other hand, for 'Learning to Manage', the most difficult module in his opinion, he was not sure whether he really understood it or not because there was no way for him to apply the theories in real life (transc2:14). According to him, it was not the language that was difficult, as he could understand every sentence. The problem was he felt that he knew nothing after reading or after a lecture because he did not know how to use the theories (transc2:10). In short, M1 was aiming to fulfil the tasks assigned by his tutors, and his idea of learning and understanding was to be able to apply theories to real-life situations.

Occupied as he was by the readings, classes, group work<sup>15</sup>, etc., he still managed to read non-academically, listen to and watch news, which also reflected his good time-management. Since he was very interested in news, especial those on current affaires and sports, he listened to BBC Radio Four, or watched Reuters pre-recorded online videos during his meals every day, the amount of time spent varying each day depending on how busy he was (transc2:5-6). In this way, he exercised his listening as well as obtained information (transc2:6). He did not browse news websites everyday, since the radio and the online video clips provided him with enough information. He would only browse the news when he needed short break from his academic readings (transc2:6). He also started reading the Bible because he was always curious about it and happened to know a Korean pastor who was willing to guide him in his reading. He studied the Bible sentence by sentence, thinking it over, and underlining whatever he could not understand so that he could ask questions when he met the pastor. Another book he was reading every day was one on interpersonal relationships, recommended by his Canadian flatmate when M1 asked him for advice as to how to improve his 'business skills'. He read this book in a similar way as he read the Bible, thinking as he

---

<sup>15</sup> There were group tasks for each module (transc2:11).

went on, and linking to his own behaviour in the past or how he should do in the future. His Canadian flatmate discussed the book with him regularly. M1 used the time before he went to bed for these two books every day. The majority of his readings were in English because there was no need to read them in Chinese since the news on sports and world affairs were mostly translated from English to Chinese anyway (transc2:6). Only occasionally he read 'The Art of War' by Sun Zi, which was in classical Chinese. From the way M1 arranged his time, I tend to see him as a person with a clear view of what his purpose was and how to fulfil it. And it seemed that he was a very well-organized person, too.

M2, though also spending most of her time reading before and after class, doing case studies and group work, etc., had a different priority: she would definitely finish reading case studies before group discussion no matter how late she had to stay up, as she did not want to be unable to contribute anything; she would not read much for 'Learning to Manage' because she was not interested in it and the exam was scheduled a long time away; she finished previewing 'Finance' every time since there was something new to her that also interested her; whereas she only previewed 'Economics for Managers' very briefly because she had once taken a similar module in China and this one here was an introductory course which she did not think need much time (transd1:10, 16). She further pointed out that if something was closely related to her life, she would have more interest in learning it. And one reason for coming abroad to study was because she wanted to learn something practical and useful, unlike in China, where she did not think she learned many useful things (transd1:16). She would not mind tackling difficult readings as long as she was interested in them, whereas she would not bother having a look at anything uninteresting (ibid.).

It seemed clear that M1 and M2 had their own more or less different priorities in

their study, yet both were making their way towards the final degree—the overall ‘object’ of their study abroad. One similarity between them was that they both seemed to be concerned about the relevance of what they learned to their real life situations. Or in other words, they were better motivated to learn what they could apply to their lives<sup>16</sup>. With respect to reading, the ‘object’ of reading for different modules appears to have varied. For instance, while reading the ‘Finance’ course book, they needed to understand not only the theories and principles, but also the calculating process through which a problem can be solved and results obtained; for ‘Operations Management’, they needed to be able to do the case studies by using the theories introduced in the course book; while preparing for ‘Finance’ exam, in addition to trying to understand the theories and the illustrating questions and resolutions, they also needed to do exercises to check their understanding. (transc2:12, transd1:14). While they were reading for writing assignments, the ‘object’ may again differ from what was mentioned above for the term time reading, which will be discussed in detail in the subsequent chapters.

### 5.3.4 Summary

In answering RQ 3, (*What are the main kinds of academic reading practices which the students experience in a UK university setting?*), the discussion of the four subjects’ reading practices above seems to show the following. Firstly, the majority of the reading that they did involved them in the study of their subject areas in English, which was a huge change for E1, M1 and M2 in terms of the subject area of the reading materials (because they had studied mainly English language for their first degree rather than education or management), and for E2 in terms of both subject area and the language of the readings. Such reading also involved them in new academic reading practices such as reading in order to plan academic research, mastering new

---

<sup>16</sup> E2 also had similar thoughts in this respect.

referencing practices, and so on. Each of them seemed to have responded to these challenges and developed certain approaches and “tips” to help them tackle the readings—e.g., E1 searched the Internet for Chinese equivalents of the English reading materials; E2 and M2 relied on note-taking to help their understanding; M1 and M2 tried to make links between the theories and everyday life to facilitate understanding.

Secondly, it seems that the ways in which the four subjects approached their academic reading tasks and reading in general largely reflected their usual attitudes toward reading and learning, as described in Chapter 4, which came into shape over years of their education experiences. For example, E1 still did not bother to read whatever did not interest her unless she had to do so for the purpose of assessment; E2 still did the minimal necessary readings as required by the tutors regardless of her interest, as she always did as an average student; M1, diligent and well-organized as he was, tended to do as much reading as he could manage in order to learn better and to make links to his life, which was his usual practice; whereas M2, similar to E2 in that she also tried to keep up to tutors reading requirements, she would also go beyond that to read more about what she was interested in, as she normally did before she came to the UK. It seems that their self-perception as students and as persons always played a crucial role in the decisions they made concerning reading, and consequently also influenced their experiences associated with reading for writing assignments, as will be discussed in the following three chapters.

Thirdly, the discussion above (i.e. sections in 5.3) seems to indicate that besides the self-perception which is established over time, the more situational factors such as the subjects' purpose for doing their masters' studies abroad and their recent education and work experiences also played a part in determining their reading practices, such as

the choice of what to read and how to read them, how much effort to put into certain course, certain readings, and certain assignments, etc. This point will be further elaborated in the analysis of reading for writing assignments in the coming chapters.

In short, in the UK university setting, the four subjects made certain adjustments in their reading practices in accordance with the differences in the readings they needed to handle now from what they were used to in the Chinese universities before. However, they seemed to largely keep their usual attitudes towards reading and their usual reading practices as a result of their educational and working experiences in the past. How this affected their masters' studies as a whole will be discussed in Chapters 6-8. Next however, in order to further explore how the current contexts of the masters' programmes took effect on the general reading practices they experienced in Lancaster University, I turn to a discussion of the two masters' programmes from an Activity Theory (AT) perspective, which also prepares the contexts for the analysis of their academic reading practices in the subsequent data chapters.

#### **5.4 The Masters' Programmes as Activity Systems (AS)**

In this part, the MA in Education programme and the MSc. in Management programme will be analysed in terms of an activity system (AS) framework. The focus will be on the continuity and/or discontinuity of the components in the current AS in comparison with the one the subjects experienced during their undergraduate years in order to see the possible different effects of the past and current contexts. I will talk about each of the six components in the activity system, relations between them, and connections and/or disconnections between the current system and the past one. In the discussion of the activity system, emphasis will be put on reading as this is the main concern of this study as a whole.

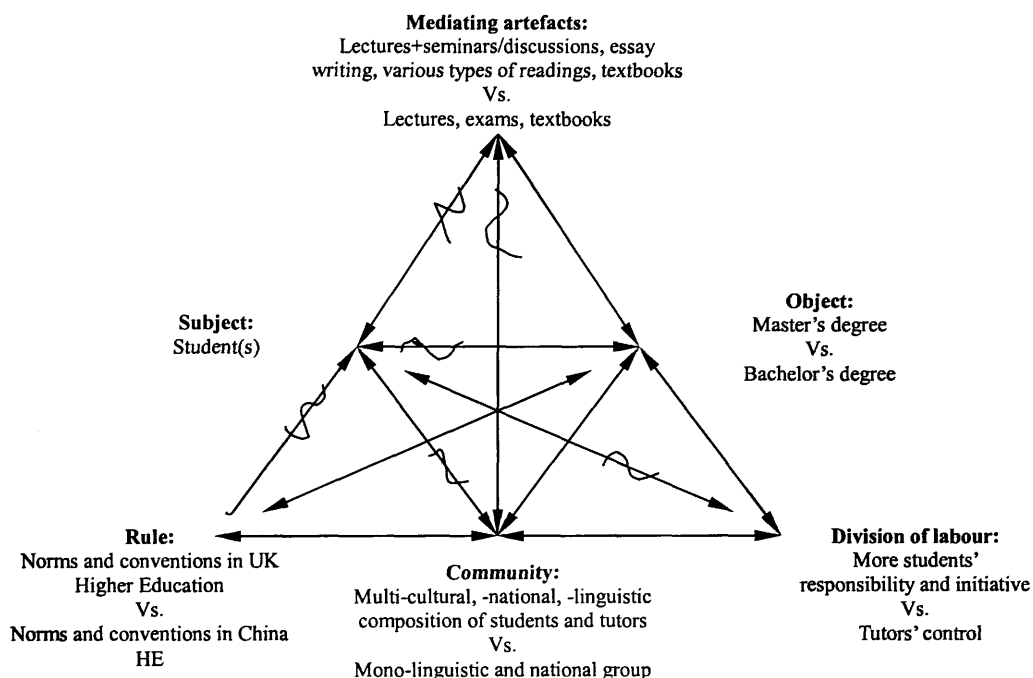

Figure 5.1 A comparison and contrast between the activity systems of the subjects' undergraduate studies in China and masters' studies in the UK.

#### 5.4.1 'Subject'

The 'subject', from whose point of view the activity system will be constructed, are the four students. E1, at the starting point of her MA study, had a BA degree in English Language and Literature, and two years of working experience as an English teacher in a tertiary institution in China; whereas she started her undergraduate study right after graduation from secondary school. She came to do the MA in Education programme at Lancaster University by carefully considered choice, which took into account the reputation of the university, her personal interest, her future direction of career development, etc. Whereas her choice of the subject and university for her first degree was more determined by external factors, such as the opportunity of being exempted from the highly competitive College Entrance Exams but with very narrow options of subject areas (mainly foreign languages and literature), her parents' wish for her to study in their hometown, her lack of interest in any particular subject or university and



so on. In short, at the point when she started her MA course, E1 was the same yet different person with a different history of study and working from the time when she started her undergraduate study. The same was true for E2. At the point of starting her MA studies, E2 was a new graduate in History Education, who would like to seek a further degree for a better career than just being an ordinary history teacher at an ordinary school, whereas four years ago, she chose to study history education out of a pure passion for history without thinking much about her career prospect<sup>17</sup>. Though she did not work as a teacher formally, she had experience of teaching as a student teacher, which also made her different from the person she was four years ago.

At the starting point of the MSc. programme, M1 had a first degree in English for Science and Technology. He had intended to do a master's degree in Computer Science right after graduation, but this was delayed by the outbreak of SARS in China. While working temporarily as a web programmer for a company, the manager who was in charge of training new staff made M1 realize that being a programmer cannot secure a good future in his career, which made him decide to do a management degree instead. And the MSc. programme at Lancaster University, which is designed for people without a business background, became an ideal choice for him (transc2:8). M2 had a BA degree in English Language and Literature. However, she did not want to be a teacher, and she did not think her study prepared her for other jobs. As her parents were running a business of their own, M2 was also interested in business. But she would not like to do an undergraduate degree again, and the MSc. in Management programme at Lancaster University was just the right programme for her. Just like E1 and E2, when they started their master's programme, M1 and M2 were very different from the time they started their undergraduate studies in terms of their educational and working experiences,

---

<sup>17</sup> She expressed her regret about not putting English as her first choice for undergraduate study (transb4:12).

career plans, etc., though the essential characteristics of their personality may not have changed a lot. This overall trait is reflected in their interactions with other components of the AS as will be discussed later in sections 5.5.2, 5.5.3, and 5.5.4 below.

#### 5.4.2 'Object'

As is discussed in Chapter 2, the 'object' is what the 'subject' is working at. It is partly given and partly anticipated; it is constructed by the 'subject' and "gives shape and direction to activity" (Engeström 1995:397). Broadly speaking, the overall 'object' of the students taking the masters' programmes was to get their degrees. Yet how each individual student got to that end and how much s/he gained from the programmes may differ greatly. For example, a student may be more interested in one module than another, hence may spend more time on it and may benefit more from it<sup>18</sup>; a student may only aim to get through the assessment of all subjects without considering learning at all<sup>19</sup>, while some others may aim at learning at the beginning and find they could only manage to focus on the assignment<sup>20</sup>; a student may be interested in some content of a module while not interested in the rest, and hence may choose to write essays in one topic rather than the others, which results in the fact that different students are actually working at different 'objects' even for a same module<sup>21</sup>. In a word, the 'object' is manifold, and changing over time depending on the students' motives, preferences and priorities as shown in 5.3 above.

While talking about reading in particular, the 'object' can be the understanding of the key concepts, and theories (e.g. E1's case below); it can be the understanding of the connection between the concepts and theories and the existing applications of them; it

---

<sup>18</sup> One example is E1's preference for module IER over TLA.

<sup>19</sup> E3, who was not reported in detail here, was a case in point.

<sup>20</sup> Such as in E2's case.

<sup>21</sup> For example, E1, E2 and E3 were working at different 'objects' for module TLA.

can be the identification or discovery of possible application and/or connection of the concepts and theories to the students' own situations; it can be the formation of a critical view of the concepts, theories and applications (as mentioned by some tutors in their interviews, transst1:4-5, transst2:1); or it can be the construction of a piece of written work in accordance with the assessment requirements, which may cover some or all of the aspects mentioned above (as the discussion in the subsequent chapters may show). It is partly given in the sense that it is officially set, since the module has been designed by members of staff and approved by different layers of committees, and will be checked in the form of assessment that is designed and approved through the same procedures (transst3:7). At the same time, however, it is constructed by the 'subject' during the course of activity. As shown in the interview data (in all four cases), at the beginning of a course, students might not be absolutely sure about what and how they will learn. As time went by, they might see more and more clearly what they would like to invest their time and energy on and how to do that. It is also likely that they might shift their focus of attention more than once during the course, until they finally decide what they would really like to work on. The process of constructing the 'object' thus gives direction to the activity that the students are engaged in. I will use E1's case to illustrate this point as follows.

In E1's case, for the TLA module, she started with making some efforts to understand the basic concepts and theories. She described her experience of reading the materials that were handed out to the students at the beginning of the term,

总的来说我觉得这个难度蛮难的，理论性特别强，而且单词特别多，…前面整段的，一直到这边，全部都是在讲建构主义的，Vygotsky的一些理论。那么这些理论我们根本不懂，所以说就很难，有些名词就根本不懂。…不光是有些生词，就是不光是认识上的，生词，还有些甚至是意思，整句意思，你单词都明白，你整句串在一起意思不明白。…例如说你常常这个叫 ZPD 这样的概念对吧，每个单词我都能认识，但是我把它搁在一起我都不知道怎么翻译，如果你让我翻译成中文，但是我如果看见中文我就更能形象的理解它。…我会上网去查中文的 Vygotsky 的理论。我会查他和 Piaget 的理论，我一看了就会懂很多。

On the whole, I think it (the reading) is rather difficult, extremely theoretical with a lot of

new words. ... From the beginning up to this part, paragraph after paragraph is all about constructivism, Vygotskian theories. We don't know them at all, so they are very difficult. Some nouns are simply beyond understanding. ... Not only the new words, but also the meaning ... of the whole sentence. Even if you know every single word, you can't understand the meaning of the whole sentence. ... For example, the concept of ZPD. I know every word, but I don't know how to translate the term while the three words are put together. But if I can read the Chinese version, I can understand it better. ... I searched the Internet for the Chinese versions of Vygotskian theories, his and Piaget's theories, and I understand much more after I read them (transa1:33-35, my interpolation). It seems to show that she was struggling with the terminology and basic concepts in the theories that the tutors would like to discuss in this module. There was no indication that she was paying attention to the application of the theories or the connection of the theories to her own situation, though it was what the tutors were trying to encourage, as most of the readings handed out were articles of different applications of theories, and discussions on such readings were also carried out during the lectures (transst1:5, transst2:1-2). Therefore, at this point, E1's 'object' in the activity system of this particular module was the understanding of basic concepts and theories. Gradually, E1 started losing interest in doing the pre-reading partly because she found that the content was quite irrelevant to the educational context that she used to and will work in, and partly because she had to spend more and more time on the IER module assignment which would be due in the middle of the first term, whereas the assignments for the TLA module would not be due until toward the end of the second term. Apart from going to the lectures, which she remarked as 'useless<sup>22</sup>', E1 literally stopped any engagement in this module, which she resumed when it was time for the submission of the assignments.

In the 'Introduction to Educational Research' (IER) module, she focused on the first assignment at the very beginning. In week two, she started to think about the topic for this assignment—a research proposal, where the students were asked to write a proposal for an imaginary piece of research in whatever topic of their choice. Since the research

---

<sup>22</sup>She said that "the only feeling I get about the lectures here is that 'go and do reading, (because) there's no use attending the lectures'" (transa1: 37).

methodology was a new area to her, and she found that the course book set by the tutor quite difficult to understand, she looked for simpler books of similar content in order to get herself familiar with this area as soon as possible. As she was trying to decide on a topic for the imaginary research, she also made her decision on the research method she would use for this research. Questionnaire was chosen as the research method because this topic would be covered before the deadline of this assignment. With the help of the lecture, she hoped to understand this method better than just reading about it by herself alone. Meanwhile, she was not very keen on doing pre-reading for sessions that were irrelevant to her assignment. Therefore, for this module, the 'object' of the activity system was centred on the construction of a piece of work for the purpose of assessment, which involved understanding of the key concepts and issues involved in the design of research.

The foregoing discussion indicates that, from the point of view of the 'subject', the 'object' of the activity system was not set at the beginning, nor was it static throughout the process of activity. It was partly given but also constantly shaped and reshaped by the 'subject', depending on their shifting and emerging interests, needs, and priorities, thus giving changing direction to the activity. The discussion of the construction of the 'object' will constitute an important part in the analysis of the subjects' reading for writing assignments in the next three chapters, as this aspect is particularly revealing of the details of the subjects' reading practices.

### **5.4.3 'Mediating Artefacts'**

In this section, I will talk about the 'mediating artefacts' of the MA in Education and the MSc. in Management programmes that the subjects were making use of in order to construct the 'object' (mainly using the MA in Education programme as an example), and then point out the differences in this respect between the two

programmes. The discussion in this section will thus form the basis of the comparison and contrast between the 'mediating artefacts' in the AS of Chinese education system and the Lancaster AS, in section 5.5.2 below. It will also act as the basis for the discussion in the final chapter of this thesis about how the differences between the 'mediating artefacts' in the two masters' programmes may have affected the subjects' academic reading experiences in the UK (see 9.4.3 below).

In the MA in Education programme, as indicated in interviews with the students and tutors (transa1:30-31, transa4:1, transb6:10-12, transst1:1-2, transst2:1-2, transst3:1-2), most modules were taught courses, which were usually delivered in the form of lecturing combined with various activities including pair or group discussion of readings and/or videos, questions and answers on certain concepts, issues and the like. There were usually some pre-reading tasks before each lecture, and other readings were suggested afterwards. There was also a module called 'Self Directed Study', for which students needed to find their own interests and explore them with the help of a tutor familiar with those particular areas. The form of assessment for all courses was writing of essays ranging from 1500 to 3500 words in maximum, some of which were more theoretical and others were more practically oriented.

To be more specific, for each module, students usually got a course handbook or outline in the first session, stating the course objective, topics covered, pre-reading materials, further reading references, form of assessment, deadline of submission, names and contact details of lecturers, etc. (see appendices 7, 8, 11, and 12 for representative examples). For some modules, or some sessions of some modules, tutors provided paper copies of pre-reading materials. For example, as one tutor mentioned in an interview:

[F]or this particular course, for the Teaching Learning course, what we managed to do is that we organized all the readings before this course started. So we gave the students a reader pack at the very beginning of the course. So they had all of the readings for the

whole of the term. (transst1:2)

For some sessions/modules, tutors recommended course books and asked students to buy them. For some other sessions/modules, tutors gave references for pre-reading materials and students needed to get their own copies from the library or e-database, because as one tutor said,

[P]art of what we hope people will learn to do particularly in the first term of the master's course is to use the library and to use the electronic resources that we have. Um, and our experience is the only way of doing that is to make it a required part of the course activities and you find them (transst3:4).

Most of the courses were team taught, which means there were more than one tutor teaching on a given module, and although in most cases there was only one tutor for each individual session, there were some sessions taught by two tutors together. The reason for this was sometimes

Because it's, research method is a generic course ... It's not such a content specific like 'gender and education' might be or 'policy'. All of us in the department conduct research, and we all have research knowledge about methodology. So it seems best we give people a variety of perspectives from the people who are expert in those particular techniques (transst3:6).

According to another tutor,

(It) is because the understanding on our MA is that we will teach in a team. ... And that one person doesn't do the whole of the course. ... [T]eam teaching is partly to do with, with knowing where we've got, maybe slightly different things to say about the same topic (transst1:2).

Because the modules were team taught, different tutors may have different styles, and different topics may be taught in different ways. For example, one tutor mentioned that she tended to do more "presentation", while one of her colleagues tended to "do more work around the reading" (transst1:2). Another tutor, who did more than one session in a module, conducted the sessions in different ways according to the topics. In two sessions on philosophical issues in research methodology, she used a mixture of presentation with power point slides, and group discussion activities (transst3:2). Because of the topic—"introducing philosophical ideas, it's hard to have practical activities" (transst3:2). So she

got students to generate their own ideas, a list of research interests that people had, and tried to move from the questions into practical research strategies, using people's own

questions, and then (they) talked something about what philosophical assumptions people were making in asking specific questions (transst3:2, my interpolation). What the tutor did was trying “to start from students’ own interests so that they can connect these what are quite abstract issues in terms of philosophy” (transst3:2). Another session done by the same tutor, where she was modelling the process of comparing two research papers, was “quite different from the way (she) would teach in other kinds of topics (transst3:1)”. The students were asked to get copies of the two papers for critiquing by themselves and read them before coming to the session. There was a brief discussion of students’ general impression of these two papers, and then the tutor presented the ways of evaluating research papers, e.g. questions to ask about the papers and aspects to comment on. Students were divided into groups of 3 or 4 people to discuss the papers following the methods introduced by the tutor, and reported the results of their discussion to the whole group (observation of an IER session).

However, from the students’ point of view, the modules in the MA programme appeared to be more or less taught in the same way—lecture and seminar/group discussion based on video clips or readings. During the lectures, tutors may also pose questions for the students to answer. PowerPoint slides were the most commonly used visual aid in lectures and tutors usually provided handouts for the lectures (e.g. transa1:31-32).

Library and online resources should also be mentioned because they played an important part in students’ academic studies here in the UK, which was not always the case in the students’ studies in China. As E1 commented: “only after I came here did I realize how useful the library can be. In China, I seldom used it except when I was writing my dissertation<sup>23</sup> (transa1:23)”. In E2’s case, she did use library quite often because she had quite a few essays to write as an undergraduate (transb4:17). In the UK,

---

<sup>23</sup> In China, E1’s tutors did not usually assign readings other than textbooks; or at least E1 managed well without doing much reading. Therefore, the library did not seem very important to her at that time.



students had to find readings in the library according to tutors' recommendation, or sometimes had to search the library catalogue to find readings according to their own interests or needs. Students also used the search engines such as Google Scholar and e-journals very often. Whereas in China, the Internet only started becoming widely used towards the end of E1's undergraduate studies, when she could access it in her study bedroom (shared with six other girls); E2 seldom used Internet resources for academic purposes since she could not access it in her study bedroom in China.

The most noticeable difference between the two masters' programmes was concerning the form of assessment: in the MSc. in Management programme, examinations were an important part of the assessment, usually combined with assessed group work tasks and/or individual essays. The convener of the 'Learning to Manage' (LM) module explained the idea of combining exam and essay in assessment as follows:

[O]bviously it is good (for the students) to have the possibility of expressing ideas and of playing with ideas by proposing their own voice in an essay. And then the limitation of that is that (i.e. what the student chose to write about) obviously is only one subject. And therefore the exam enables you to at least have a different choice and evaluate the different areas we touched upon, at least giving them the choice, because they can choose from different questions in the exam (transst4:6-7, my interpolation).

Another lecturer also thought the idea of assessing students by both essay/report and exam was positive, saying that

[T]he report is supposed to be a fairly detailed review of the literature and original application of economics principles to a particular problem. ... The exam, on the other hand, is about testing their knowledge of economics and the principles. ... So one is looking at testing their knowledge of theory and the other is at testing their ability to apply the theory to practical problems. Two different things (transst5:6).

So the tutors basically thought that the two forms of assessment were complementary to each other so as to get a fuller picture of what the students have mastered.

Assessed group work was another important difference between the two programmes, which was probably determined by the nature of the programme teaching-learning approach, just as a tutor in the Management School commented,

[W]e wanted them to learn to work together. It's a management degree and part of

working in management is working with people. And so working as a group, you could put them in a faithful environment in which they were actually asked to work with people they might not like, they might not know, they definitely don't know, and who have different cultural backgrounds and beliefs. ... Quite a lot of groups have problems—they don't talk to each other, that some don't get on, some argues, some have problems with individuals who don't turn up. So they have to manage that situation. In fact they have to learn how to manage (transst5:4).

Apart from these two distinctive differences, however, the other aspects of the 'mediating artefacts' of the two masters' programmes were largely similar. Thus, in both programmes, these included course handbooks/outlines, handouts/lecture notes, textbooks and other readings, seminars, pair or group discussions, video clips, PowerPoint slides, library resources, e-journals, etc. Taken as a whole, the 'mediating artefacts' in the AS of the two programmes can be seen as having involved the subjects in having to come to terms with the new features of their academic contexts at Lancaster University. In this connection, the discontinuity between the 'mediating artefacts' of the Lancaster AS and the Chinese AS will be carried out in 5.5.2 below.

#### **5.4.4 'Community'**

'Community' in the AS here mainly consisted of the fellow students, and tutors of the subjects. Lancaster University, as a whole, has a very mixed student population in terms of nationality, ethnicity, age, religion, culture, educational background, and personal history. The teaching staff also consists of people from different countries, or different parts of this country, with various backgrounds. In the MA programme in Education (academic year 2004-05), the majority of the students came from China (12/16, including one student from HK), there were four British students, one Japanese student and one U.S. student. The composition of the 'community' in MSc. in Management programme was more diversified than that in the MA in Education programme: there were students from many different countries including China, India, Thailand, Japan, UK, US, Italy, Greece, and so on; the student population was much bigger (over 100), so that they had to be divided into two cohorts for all lectures and

seminars; about 50% of the students were Chinese, which was not as high as that in the MA in Education programme; there were tutors from different countries too, including the UK, Italy, Germany, Iran, etc.

Although MA in Education group might not be as diversified as some other programmes in this university in terms of the ethnic groups the students belong to, the students still had very different educational background and past experiences. When E1 and E2 first entered university in China, their classmates were mostly new graduates from secondary school<sup>24</sup>. So even for E1 and E2, the MA group was also more mixed than their undergraduate classes. And this new 'community' was governed by rules and norms that were very likely different from what they were familiar with in China.

#### 5.4.5 'Rule'

In a broad sense, 'rule' here can refer to what makes the higher education system function the way it does. To be more specific, they were guiding principles, both explicit and implicit, for how degree courses should be designed, how each module should be organized, how students should be assessed, what is expected of the staff and of the students, and so on.

In the MA in Education programme, examinations were not part of the assessment. The students only had to write academic essays (including shorter pieces such as report of small-scale research, and a longer dissertation). The danger of plagiarism was very much emphasized and seriously penalized, which was not the case in China at the undergraduate level (according to my own experience and that of E1, E2 and M2's). The writings of the MSc. in Management students were checked by certain software to detect suspicious cases of plagiarism. Correct referencing was considered very

---

<sup>24</sup> There may be students repeating the College Entrance Exams more than one year in order to get better marks for better universities. There are rarely any mature students in the undergraduate education system in China.

important in the UK setting, which, as E2 and M2 complained, had not even been properly introduced to many of the Chinese students before they came to do their masters' degrees. In the MA in Education programme, it was common for tutors not to choose a single textbook<sup>25</sup>, but to recommend core reading from different books or journals for different sessions or topics, which often meant that students themselves had to find those readings, and read them; whereas MSc. in Management students usually had one course book (or sometimes two) for each module.

Besides the rules that were stated clearly in the course handbook/outline, such as the standard of assessed work, submission deadline, marking criteria, etc. there were also less explicitly stated norms and conventions that were also important in the functioning of the masters' programmes. From the interviews with various tutors in the MA in Education programme, at the MA level, it seemed that students were expected to take more responsibility for their study, such as to prepare for the readings before attending the lectures. As one tutor mentioned,

I think this expectation comes out of what I witness. I think I expect them to be more engaged, you know, to come always having prepared the material. I mean they do seem to generally be quite enthusiastic and quite motivated. And that, you know, because, I mean I've been teaching them here in this department for four years, and I think over that time, I've come to expect that because of the way they are, the MA students (transst2:7).

This seems to indicate that the 'rule' is not formed solely on the basis of what the staff thought right for the students to do, but also partly on the basis of students' behaviours. Another case in point was that tutors do not usually expect students to read from the further or additional reading list until they come to do their assignments, because as one tutor said, "there's no point in asking them to do it early on because they wouldn't do it (transst3:4)".

Having said that, tutors that I interviewed pointed out that they "don't think that (their) presentation (in lectures) relied on anybody having done the reading (transst1:7,

---

<sup>25</sup> It is more common in China for tutors to use one textbook for a course.

my interpolation)", though most of them did think that the students "missed out on an important part of the content (transst2:2)", or cannot benefit as much from the session if they did not prepare the readings. However, even if the students failed to prepare the essential readings for a session beforehand, the tutors would still hope the students could get something from the session by having "the experience of talking to people who have read" rather than ask them to "go home and read" (transst3:5).

Another aspect of expectations was that tutors expected students to approach them and contact them if they have any queries. Quite a few tutors mentioned that they had invited people to contact them by email, at the end of the lecture sessions, or during office hours. One tutor expressed her concern by saying

Culture, I mean it's culturally different here in the whole country, the learning culture is different as well. ...The students who get on better I think at the end of the day are the students who mix more. ...because ... it isn't just the reading and the sitting in this, in the class. There's the whole kind of cultural soaking up that you need to do as a postgraduate I think (transst1:9)'.

Such remarks indicate that, Chinese students might do better in postgraduate education in the UK (in contrast to their undergraduate studies in China, where they know the conventions sufficiently well to not have to ask for extra information), if they were to take advantage of the opportunities to communicate with tutors and other students about their ideas, problems, or anything they need advice for, rather than just studying on their own. To sum up, the data show that some of the expectations about study norms were more explicitly expressed to the students than others, but the main point is that a thorough understanding of both kinds is likely to help students make the most out of the modules.

#### **5.4.6 'Division of Labour'**

'Division of labour' refers to the horizontal division of tasks between the members of the community and the vertical division of power and status. In Chinese higher education system (viewed from the four cases in the current study), tutors assumed

most of the responsibilities regarding the input of knowledge (lecturing being the dominant form of delivery of courses), the choice of readings (tutors determining the textbooks and other readings), methods and scope of assessment (tutors giving students a reduced<sup>26</sup> scope of topics to study for their exams, sometimes even sample answers). By following tutors' 'orders', students may have no trouble in passing the exams and getting their degree. Even at the postgraduate level in Chinese universities, students may tend to wait for the supervisors to tell them what topic to choose for their research, what readings to do, and so on<sup>27</sup>. In the two masters' programmes in Lancaster University, it appears that tutors generally assume that students would take a good deal of responsibility for and show initiative in their study approach. For instance, input from lectures and reading materials was supposed to serve as a stimulus or 'springboard' (transst1:5) to help students generate their own thoughts in relation to their own interests or situations; students need to learn to search for readings on their own in the library or in some e-database rather than wait for the tutors to get all the readings ready for them. Instead of telling students what to do, tutors tended to wait for the students to take initiative in approaching tutors when they experienced problems or difficulties. Essay writing and practical projects as the form of assessment also invited the students to do more decision-making for themselves, such as what topic to choose to write about, what product to work on for a certain project, how to gather the necessary information for the project, what literature to cover, what structure to take for the organization of their ideas, what arguments to make and what conclusions to draw. In the case of the self-directed study module, students even needed to find the area of their studies according to their own interests and to suggest which tutors they would like to

---

<sup>26</sup> Reduced in comparison to the topics covered in the whole course during the term time.

<sup>27</sup> According to personal communications with a number of postgraduate students and supervisors in China (also see Cortazzi, M. and L. Jin, 1996).

have as supervisors. In short, in these masters' programmes, students such as the four subjects in this study had to play a more active and responsible role in their studies than they had previously experienced.

#### **5.4.7 Summary**

Now that I have explored the six components in turn, I will briefly summarize the continuity/discontinuity between the AS of the two masters' programmes in Lancaster University and the AS of the subjects' undergraduate studies in China (as shown in figure 5.1 above). The 'subject' of the two AS seemingly remains the same, i.e. the four Chinese students this study is concerned with, with their established attitudes towards learning and reading and self-perceptions of themselves as students and persons. However, their experiences of undergraduate studies and working experiences after graduation (in E1 and M1's cases) made them different from the time when they first entered universities in China, and might influence their decisions concerning their learning and reading during their masters' studies. The overall 'object' of their undergraduate studies and masters' studies was obviously the two different degrees. As for the 'mediating artefacts', the medium of instruction (English for the Lancaster AS and mostly Chinese for the Chinese AS) was a big difference especially for E2 who did not major in English Language during her undergraduate years. In addition, seminars and discussions, essay writing as a form of assessment, group projects, library resources and e-journals were also used more often in the Lancaster AS. The 'community' in the Lancaster AS was more diverse in terms of the nationality and ethnicity of the students and tutors, the linguistic, educational, cultural backgrounds, and working experiences. As for the 'rule', there seemed to be different sets of norms and conventions associated with Chinese and UK higher education systems. Some implicit conventions in the Lancaster AS may only be revealed to the

subjects through active communications with their tutors. As regards the 'division of labour', the Lancaster AS seemed to require more initiative and responsibility from the students than the Chinese AS. In the following part, I will move on to a discussion of the conflicts between the components of the Lancaster AS and the causes for such conflicts.

## **5.5 Inner Conflicts in the AS**

Inner conflicts refer to the conflicts and contradictions between the components of the AS (as is represented by the wavy lines in figure 5.1 above). In this section, I will first explore the conflicts between the 'subject' and other components, and then move on to examine the conflicts between other components. The discussion in this section will serve as the basis and guidance for similar discussions in the following chapters, where the details of the subjects' academic reading experiences are discussed.

### **5.5.1 'Subject'—'Object'**

Seemingly, there should be no conflicts between the 'subject' and 'object', because the former is the agent working on the latter, constantly shaping and reshaping the latter, and finally moulding it into an outcome. Yet the fact that the 'object' was not static throughout the process of the activity most likely resulted from the 'subject' discovering the conflicts between themselves and the 'object' and making adjustment in order to carry on with the activity. The discussion in the 'object' section in the previous part has shown how the 'subject' constructs the 'object' during the course of the activity on the basis of shifting and emerging interests, needs and priorities. It is this dynamics which gives rise to the potential for conflicts.

### **5.5.2 'Subject'—'Mediating Artefacts'**

One of the 'mediating artefacts', which is not mentioned in the section on



'mediating artefact' above, yet which is very important in the discussion, is language. Chinese students faced a major transition in their learning environment when they started their studies in the UK, i.e. the transition from Chinese as the medium of instruction to English, as was pointed out earlier in this chapter by the subjects in the current study. Although some of the students did their first degree in English Language, where they used textbooks written in English and attended lectures conducted in English, the whole environment then was still largely in Chinese language and the majority of the tutors are Chinese. When they came to an English language environment, they needed to make due adjustment in order to survive. For example, E1 found herself struggling in understanding the lectures as she mentioned in an interview:

我觉得在听课方面还是存在一些困难，老师的口音哪，dialect 啊，还有一些由于我们没有接触过教育学理论很多。(transa1:31)

I feel that I have some difficulty in understanding the lectures, because of the tutor's accent, dialect, as well as those education theories that we haven't seen before.

It appears that not only the unfamiliarity with education theories, but also language were causing trouble for her. M1 and M2 also complained about the accents of some tutors which added to their difficulty in understanding lectures. When it came to reading, language was also an issue affecting understanding. The part of E1's data quoted in section 5.4.2 above illustrated this point clearly—although the concepts were difficult, the Chinese versions of explanation helped E1's understanding enormously.

Another aspect worth mentioning here is the way in which sessions were organized and lectures delivered. Chinese students were used to lecturing because it was the most commonly used form of teaching in China according to the four subjects, though one difference now was obviously the language used to deliver the lectures, as discussed in the foregoing paragraph. Besides language, another more important difference lay in the ideas of the function of lectures held by tutors and students. As mentioned earlier (see footnote22), E1 did not think highly of the value of the lectures she had attended. She elaborated on this by comparing the Chinese tutors and British tutors:

讲课其实我倒觉得对我帮助不是很大，不太大。…我感觉就不象国内老师，可能教学方法不一样，他们不是很…象国内老师肯定会给我们灌输，…让你一下就那么灌到你脑子里去。…这边老师…讲得很零碎…不系统 (transa1:36-37)

Lectures don't help me much. (The tutors here) are not like those in China. Maybe (they have) different way of teaching. They don't, they are not like tutors in China who pour things right into your brain. Tutors here ... don't give you systematic knowledge.

It seems that E1 thought learning as receiving knowledge from tutors, and she expected that tutors in the UK also told her directly what was correct and true so that she could learn it quickly without thinking too much about it. E1 preferred the more passive way of learning in China, which did not consume too much of her mental effort. However, as one tutor commented, what E1 expected “doesn't happen” in the UK (transst1:9). The way in which tutors organized the sessions—presentation with various activities based on video clips, readings, or students' own experiences or interests, and the way readings were chosen (which will be discussed in more detail in 5.5.2 and 5.5.3 below), show that tutors would like the students to think actively for themselves in order to make sense of what was discussed in a session. As a tutor remarked,

The main thing I want to do when I'm teaching is I actually really want to have a dialogue with the students. That's more important to me, and I will, I prefer to engage them in talk, rather than to have them kind of looking at, at some reading. ... what's more important for the students is that they get this particular opportunity to argue about some ideas (transst1:4).

In order to be able to argue about their own ideas or to have dialogues with tutors in teaching sessions, it would seem necessary for the students to engage with active thinking, rather than just sit and listen.

Related to the issue discussed above, E1 had another complaint about some lectures, saying that what got talked about in the lectures (i.e. teaching-learning situation in UK primary and secondary education) was not relevant to her own teaching contexts (i.e. tertiary education in China). The tutor's understanding of the function of the lectures was that “if you are talking about teaching and learning (the main topic of the module), you are talking about some basic principles about how people learn, and so you can apply those principles to any learning situation. ... it doesn't matter kind of what context

you are looking at, you can still actually draw these things out (transst1:11)". Again, it illustrates that the purpose of the lectures was not only to introduce theories or concepts to the students, but more importantly to make the students think how relevant the theories were to their own situation and to show the students possible ways of connecting theories and practices to guide their thinking. In this respect, there seems obviously a mismatch between the tutors' and the students' understanding of the function of lectures and more broadly the objective of learning.

There were other 'mediating artefacts' that had different meaning and function to the subjects in their current situation compared to the past. For example, the library and the enormous online journals and other information resources were playing an important role that some subjects (e.g. E1 and E2) had never experienced before. Textbooks and journal articles also had a different role to play in the subjects' process of study, which will be discussed in the following section.

### **5.5.3 'Subject'—'Community'**

The conflicts between the 'subject' and the 'community' seemed mainly to lie in the relationship between the Chinese student(s) and tutors. And such conflicts most likely arose as a result of the different understanding of learning, of the function of teaching sessions (as the discussion in the foregoing section demonstrated), of reading and the function of the reading materials.

For example, there was one module—'Learning to Manage' in the MSc. in Management programme, with which both the tutor and the students (M1 and M2 and some others who exchanged ideas with them about this module) were not satisfied. The students (M1, M2 and some others) were complaining about the abstract theories discussed in this module which seemed irrelevant to their real life, about the difficulty in understanding the readings and the lectures, and about learning nothing from this

module (transc2:9-10, 14, transd1:11-13). When I interviewed the tutor, she was complaining about students not doing their readings, even though she only asked them to read one course book for that module as she was required by the Management School to “make things as simple as possible because of the diversity of the students, (and) because they are new to management” (transst4:2-4). She further pointed out that the students found the module difficult because they did not learn it in a proper way, as she said in the interview,

I find the students kept saying this is too difficult ... because they try to read it once. ... Yes, it's too difficult because you never study this. ... Every time I said, look you have only read it once, and probably at first glance you would understand this bit. Then you read another time, you understand this bit, and you read another time, you understand this bit ... I told them to talk to others, discuss it with your colleagues. Discuss it together. Take the lecture on the one hand—all the notes you have from the lecture; take the chapter on the other hand. Compare, and bring them together. That's what learning is about. ... When they come to do a master, they should already know how to do the things. I shouldn't teach how to read and how to study a chapter, because they should know. (transst4/2:5-6)

According to the interviews with M1 and M2, it was true that they did not learn in the way the tutor described above. This might be partly because the exam was not due until the start of the summer term, which might give the students a false impression that they could postpone studying it and allocate their precious time to other courses; partly because they were new to management so that they were unable to find the relevance of this module to their life; and partly because they were not familiar with the way of learning required by the tutor. As the tutor pointed out in the part of the data quoted above, it was not her responsibility to make the students realize how they should learn, but on the other hand, it was very likely that the students (such as M1 and M2) were not aware of the desirable way of learning even though they had attended the pre-sessional study skills course. The question here is who should be responsible for raising students' awareness of the possible discrepancy between the tutors' expected way of learning and the students' actual performance, an issue which will be discussed in the concluding chapter.

The tutors' and students' different understanding of teaching sessions has been discussed in section 5.5.2 above. Here I will talk about the different understanding between the tutors and the subjects about reading and the function of reading materials. According to the interviews with all four subjects and some of their tutors, there were usually some readings (e.g. book chapter(s), journal article(s), etc.) to prepare before each lecture session for all courses. All four subjects reported that they usually considered readings as sources of theories, principles, concepts, etc. in the subject areas that they were studying; and they relied on the lecture sessions to solve questions they had while doing the pre-reading, which did not always happen as E1's quotation in section 5.5.2 above indicated and M2 even complained that sometimes lectures further confused her. From the tutors' point of view, however, lectures and readings not only served as sources of theories, concepts, etc., but also as stimulus of thinking, as one of the tutors remarked,

You know, the reading is just ... the *stimulus*. ... And when you pick the reading for the lesson, you try to pick something that's going to *create argument that's going to make the students think*. I don't pick it because I necessarily think it's a central piece of work, or has anything amazing to say necessarily, ... I don't pick something because it's classic. I pick it because I want the students to identify the argument and engage with it. ... I do tend to do that (referring to the reading) when I'm teaching. ... I'm trying to make connections for the students, which they might not make themselves. ... what I'm trying to do is to help them do the reading rather than round the other way. ... what I am ... doing there is trying to make the link, and what I hope will happen is that they will remember the link when they do the reading, that they will remember the link because I've embedded it into what I said (transst1:5-6, my interpolation).

The part of the data quoted above seemed to show that the lectures may not necessarily or merely be the explanation or interpretation of the pre-readings that students like E1 and M2 had expected. Instead, readings and lectures, together with other materials such as video clips, websites, discussions, were supposed to help students grasp the theories, concepts, principles, etc. that tutors were trying to get across and to encourage students to engage actively with what they were supposed to learn. Yet E1's view of lectures being useless appeared to indicate that from the students' point of

view, the readings and lectures may not work in the way that the tutors would like them to.

Observation and a follow-up interview with one of the tutors also indicated that Chinese students such as E1 and E2 may not do reading in a way that the tutors think appropriate, which I will describe and discuss next. In a session of the TLA module that I observed (November 2004), the tutor set out a few questions for the students to discuss about the reading. The students were divided into four groups according to their seating, and there were two Chinese groups (because Chinese tended to “stick together” according to the tutor, transst1:5) and two mixed groups. Three questions were given and the students could choose one to discuss about. The tutor circulated among the groups to check the discussion and to answer questions. The questions were as follows (as in the session handout):

To think of a further study which will find out more<sup>28</sup>:

1. What might account for some or all of these results?
2. What question is your new study asking?
3. How will you answer your questions - what is the design of your study? What sort of data will you use and how will you analyse it?

Judging by the questions, it seemed that the tutor would like the students to think of anything that the reported study could not or has not yet accounted for, which the students themselves were interested in knowing about. In the interview following the lecture, the tutor pointed out:

what I'm trying to pull out when I'm getting them to do the reading, is you get them to see what the argument is in a piece of writing, and to actually make challenge to the argument or to see where the argument fits (transst1:3).

The two groups which were situated close enough for me to observe worked very differently. One group of three westerners and one Chinese talked with the tutor about their interest in one of the research findings, and issues related to this finding. The other group of four Chinese students asked the tutor the meaning of a term in the paper,

---

<sup>28</sup> The reading that students were asked to prepare reports on a research study.

without mentioning anything related to the discussion questions. It turned out that three of the students in the group had not read the paper and the fourth one read it without thinking about it in depth enough to enable her to discuss the questions<sup>29</sup>. A follow-up interview with the tutor showed that only the mixed group that I described above met her expectation of the intended purpose of the discussion, as she commented:

What I found is that ... really only the group on the back, the group on this side at the back did very well with that task. And they then ended up when I went over to visit them, they have used the whole thing as a *springboard* for, really, thinking. ... That's what I want... I want that more than that they know what's in that reading. You know, the reading is just ... the *stimulus* (transst1:5-6, my emphasis).

As seemed evident in the part of the data quoted above, the reading and the discussion questions served as a '*springboard*' or '*stimulus*' for thinking. The tutor would like to see the students think about the arguments in the reading rather than just know about or accept what is said in it. Therefore, only the mixed group that I observed met the tutor's expectation. The tutor also expressed her concern about the Chinese groups:

[T]he groups on this side (with Chinese students only), when I visited them ... they asked me a question which was about the meaning of a word. ... that's quite worrying because what that means is that they've, I don't quite know how they've engaged with the reading as they prepared it. ... So what they are doing is that, ... they are reading in a way which is focusing on ... they are not focusing on the whole. They are focusing down on, as I say, on what ... individual word means. So I'm actually quite concerned that they find the reading difficult, and partly because obviously here we take, if they are reading, they are reading in a different language, so the job for them is that they are doing a big translation job. And I think partly the problem when you are doing a translation job is that you end up looking at minor detail, rather than the big argument ... (transst1:3, 5, my interpolation).

The tutor pointed out that the Chinese students tended not to see the overall arguments in a reading, and the reason for that was partly because of the language issue. She went on to attribute the Chinese students' problem with reading to the way English was taught in China according to her experience of teaching English there twenty years ago:

I used to teach English in China. I taught there twenty years ago. So I don't know how things have changed. But certainly my experience then was, and this is how I was told as a teacher as well, which was that they are very close, very fine grained analysis of all the texts in English, that translating every word, and actually looking at the syntactic structure of every sentence, but extremely insistent from the students in terms of trying to get the whole thing. ... Then they have to engage critically with it. And possibly critical reading might not be something that they are particularly skilled at (transst1:6).

---

<sup>29</sup> Based on information obtained from interviews and personal communications with some students in the group that I observed.

The part of data just mentioned above illustrated that some Chinese students did not read or use the readings in class discussions in the way that the tutors expected them to and the reason may partly lie in the way in which English was taught in China before they came to the UK. Interviews with the four subjects seemed to confirm the tutor's point above about the way in which English was taught and learned in China. M2 further mentioned that as an English major at university, she was so used to attending to the details such as the individual words' meanings, sentence structures, etc. while reading, that she could not help doing that when she started her master's study in the UK. The pedagogical implications for ELT in China will be discussed in the final chapter.

There were also activity system conflicts between Chinese students and students from other countries, which may not usually be noticed or viewed as conflicts. Chinese students were usually not as active and vocal as western students (judging from observations and interviews with the tutors in the two masters' programmes). And yet the tutors generally encouraged and welcomed students comments and questions during the teaching sessions, which often resulted in tutors' attention or the topic of discussion being directed to cater the more vocal students, whose interests and purpose of doing the masters' studies may vary greatly from those of the Chinese students. Chinese students may also benefit from listening to or taking part in the discussions initiated by other students, though most student interviewees in this study complained about the accents of British students or students of other nationalities, which prevented them from getting benefit from such discussions. In a sense, students who voiced their opinions and asked their questions were making better use of the time in class and tutors' attention and feedback. Although there were Chinese students in some rare cases who would like to take advantage of such opportunities (one tutor remembered such a 'noisy' Chinese student from last year), most of them did not do so. The reason may be



that they were not used to this kind of active engagement in lectures, or they did not see the advantage and benefit of doing so, or they did not think deeply enough to enable them to initiate a question or discussion, or they were just shy, or they were not confident with their English (according to personal communications with Chinese students).

#### **5.5.4 'Subject'—'Division of Labour' and 'Rule'**

In terms of the 'division of labour', coming from a learning culture where students were typically assigned a relatively passive role in decision-making (as discussed in Chapter 4), Chinese students may need to make effort in adjusting to a new role, which required more responsibility and initiative of them. However, before the students were able to make this adjustment, they needed to realize what was expected from them. This leads to the next issue—conflicts between the 'subject' and the 'rule'. In the 'rule' section (see section 5.4.5 above), there is a discussion on the difference between the 'rule' governing Chinese students' past activity system in China and the current 'rule' in the UK. The discontinuity of the 'rule' in the two systems was further complicated by the fact that in the current system, there were implicit norms as well as explicitly stated rules. And the Chinese students may or may not easily figure out those less explicit norms and conventions.

#### **5.5.5 'Community'—'Object'**

The conflicts between the 'community' and the 'object' were mostly caused by the conflicts between the 'subject' and 'community'. As the discussion in section 5.5.3 above indicated that Chinese students and British tutors seemed to hold different views about some key components in the process of learning, such as lectures, pair/group discussions, readings, tutor-student relations, etc., it is almost inevitable that the

students and tutors may try to construct different 'objects' during the process of activity. The difference in the 'object' being constructed by the students and tutors will also be discussed in the analysis of the subjects' reading practices for writing assignments in the subsequent chapters.

### 5.5.6 'Community'—'Rule'

The 'community' here consists of students of other nationalities and the members of staff. The conflicts between the students and the 'rule' may have similarities to the Chinese students discussed in 5.5.4 above, and therefore will not be discussed here again. The members of staff usually have a better understanding of the 'rule' as they have been in the academic community for longer time and may often involve in the design and implementation of the 'rule'. There are naturally much fewer conflicts between the members of staff and the 'rule'. However, conflicts of this kind did sometimes exist, as was evident in the interviews with the 'Learning to Manage' module lecturer (transst4/2:4-5) (see details in 8.3.2.2.2 below).

One point worth mentioning here is that the 'rule' did not seem to be determined solely by the more powerful and established members (i.e. the academic staff) of the academic community in question. For example, as mentioned in 5.4.5 above, tutors expected the postgraduate students to be more engaged in their study and come always prepared with their readings, because they seemed generally keener than the undergraduate students (transst2:7). Tutors did not expect students to spend time on further readings earlier than when they came to do their essays because students would not usually do it any earlier than that (transst3:4). Another tutor, while commenting on Chinese students' writing, mentioned that they tended to use more vivid metaphors and analogies in their writing, which he did not usually find in students from other countries. And he considered it a very effective way of expressing ideas (transst8:4). The

examples here all show that the members of staff in question were very receptive and willing to make adjustments to accommodate students' practices, rather than resist and reject them. However, there may also be tutors who are more conservative and unwilling to welcome unconventional practices, or to make life easier for students by not imposing the 'rule' too rigidly on them. Conflicts may thus arise.

To sum up, the discussion of the conflicts within the AS in section 5.5 as a whole shows that the conflicts between the 'subject' and other components primarily resulted from the discrepancy between the students' current activity system and the past ones they had experienced. Such discrepancy may add to the difficulty for the students to fully understand their current learning situation. And the different understanding of the purpose of learning and the functions of lectures, discussions, readings etc. between the tutors and students and among different students may make the situation even more complex.

## 5.6 Conclusion

In this chapter, I have attempted to answer RQ 3 (*What are the main kinds of academic reading practices which the students experience in a UK university setting?*) by discussing the details of the four subjects' reading practices after they arrived in the UK, and RQ 4 (*What are the features of the activity system of a master's programme in a UK university in comparison with and in contrast to the activity system that the subjects used to belong to in China?*) by exploring each component of the AS of the masters' programmes that this study is concerned with, the relationships between the components of the AS, and the difference between the current AS and the past one. It has been argued that the data indicate that the subjects' self-perception as students and as persons, their past educational and working experiences, their literacy history and the current context in which they were now living and studying all played a role in

shaping their current reading practices, and that the conflicts between the components of the Lancaster AS mostly arose from the discontinuity between the past AS and this one. In this way, we can begin to see the value and importance of the theoretical perspective on academic reading practices which this research has adopted. In other words, it has begun to be possible to see how such L2 literacy practices cannot be satisfactorily accounted for in terms of a 'technical skills' model of academic reading of the kind discussed in Chapter 2, which has tended to prevail in previous studies in this area. Instead, we need a theoretical framework that is capable of revealing a detailed picture of the subjects' reading practices and the dynamics of the process of academic reading activities. In this way also the nature of the major influences on the subjects' reading practices, and their effects, can be identified. This basis of understanding will be used in the following three chapters to illuminate the parts of the research data concerned with the details of the reading for assignment writing undertaken by the subjects.

Chapter Six: Doing the First Assignment - E1 and E2's Experiences .....	196
6.1 Introduction .....	196
6.2 E1's First Assignment .....	197
6.2.1 The Process of Construction of 'Object'—Five Stages.....	198
6.2.1.1 Understanding the Writing Task and Identifying the Reading task.....	198
6.2.1.2 Finding a Way into the World of 'Research'.....	200
6.2.1.3 Choosing and Developing the Research Topic .....	202
6.2.1.4 Learning to Construct a Questionnaire .....	205
6.2.1.5 Integrating Reading into Writing .....	206
6.2.1.6 Summary.....	208
6.2.2 Tutor's Comments vs. E1's Reflection on Her Reading and Writing .....	210
6.3 E2's First Assignment .....	216
6.3.1 The Process of Construction of 'Object' .....	216
6.3.1.1 Choosing the Topic—a Choice out of Convenience .....	217
6.3.1.2 Identifying and Searching for the Literature.....	217
6.3.1.3 Reading .....	218
6.3.1.4 Integrating Reading into Writing .....	221
6.3.1.5 Summary.....	222
6.3.2 E2's Reflection vs. Tutor's Feedback.....	223
6.4 An Activity System View of E1 and E2's Cases .....	227
6.4.1 'Subject' .....	227
6.4.1.1 Personal Literacy and Education History .....	228
6.4.1.2 Emotional Aspect—Seeking a Sense of Security and Certainty .....	230
6.4.2 Relationship between the 'Subject' and 'Community' .....	232
6.4.2.1 Network of Support .....	232
6.4.2.2 Conflicts between the 'Subject' and 'Community' .....	233
6.5 Conclusion.....	235

## **Chapter Six: Doing the First Assignment - E1 and E2's Experiences**

### **6.1 Introduction**

On the basis of Chapters 4 and 5, which have explored the four subjects' past education and literacy experiences and the current contexts of their academic studies, I now turn to the main focus of this study—the subjects' academic reading practices for the purpose of writing assignments. I am attempting to reveal the details of the subjects' reading experiences by looking at the process of constructing the 'object' of their reading activities, and to investigate the causes of their reading experiences by examining the relationships between the components of the current AS and the continuity/discontinuity between the Chinese AS and the Lancaster AS. As was discussed in Chapter 3 (3.3.1) above, I have decided to focus on the subjects' reading practices for the purpose of writing assignments for two modules in the first term of

their degree studies, as, judging by the pilot analysis, this type of reading practice seemed the most demanding one for the students, both in terms of quantity and quality. The current chapter is concerned with E1 and E2's academic reading experiences while writing the first assignment; Chapter 7 deals with E1 and E2's experiences of writing the second assignment; and Chapter 8 focuses on M1 and M2's experiences of doing two assignments. Through the three chapters, my intention is to see how the subjects' past literacy and education experiences (as discussed in Chapter 4) and the academic contexts at the time of the study (as discussed in Chapter 5) may have jointly affected their academic reading experiences.

As the first part of the thesis focusing on the details of the subjects' academic reading experiences, this chapter will attempt to demonstrate a productive way of applying the theoretical framework established in Chapter 2 to the data of the two subjects in the MA in Education programme, with reference to their experiences of reading for writing their first assignment for the 'Introduction to Educational Research' (IER) module. It is also intended that, in this way, a "template" for the remaining two data analysis chapters (Chapters 7 and 8) can be formed, enabling comparisons and contrasts between different subjects and their experiences across the two masters' programmes to be facilitated.

## **6.2 E1's First Assignment**

The two modules in question in the MA in Education programme were: 'Introduction to Educational Research' (IER) and 'Teaching, Learning and Assessment' (TLA). The first assignment that I investigated was an imaginary research proposal in the area of education for the IER module (see appendix 8). In this part, I will discuss how E1 read during the process of writing her first assignment—the resources she drew upon, different ways of reading and uses of reading, and the construction of the 'object'

of her activity of reading. The discussion will be based on the Lancaster activity system (AS) established in Chapter 5. Here, the activity in question is shifted from academic reading in general to reading for writing assignment. Although this assignment was their very first assignment in their masters' studies, they both got satisfactory results—67<sup>1</sup> for E1 and 60 for E2. Through the discussion in this chapter, I am attempting to account for how and why their academic reading experiences for this assignment took shape and how and why they obtained satisfactory results.

### **6.2.1 The Process of Construction of 'Object'—Five Stages**

There seemed to be five stages in the process of constructing the object in E1's reading activities for the purpose of writing her first assignment.

#### **6.2.1.1 Understanding the Writing Task and Identifying the Reading task**

The assignment discussed here was the first one ever that E1 and her course mates needed to turn in during their masters' studies. Before she engaged in the actual reading of academic texts, she first read the assignment requirements—an important type of reading related to academic reading practices—to get an idea of the writing task. She studied the writing requirements carefully and interpreted the task requirement as follows:

实际上我也发现，我们老师作，第一个作业，他/她对你学术要求上不是很严，他/她主要是看你掌握研究方法没有，对于你这个课学的怎么样，会不会写 proposal，写部分是不是写得，就说是整个，然后逻辑行不行，就这么一点。而且又不需要你真的去做那个，就说不需要你真的去调查怎么样的，得出数据然后分析。你只要作出个样子出来，你只要说句实话你的 problem 或 question 提得好，前后能够呼应，questionnaire 设计的可以。不说高分吧，至少及格应该是没问题的，我看。

Actually I find that for the first assignment, our tutors do not expect something that is very academically complex. They would like to see whether you know research methods; how well you learn this module; whether you know how to write a proposal; and whether each part is... (The proposal) is logically coherent as a whole. That's all. And you don't have to carry out the research, to get data and analyse them. You only need to 'fake it'. To be honest, if you have good research problem or question, write coherently, and design good questionnaire, I

---

<sup>1</sup> According to the Faculty of Arts and Applied Sciences marking criteria for master's level assignments, marks between 60-69 fall into the 'good pass' category (appendix 15).

can't say for sure you will have a high mark, but at least I am sure you can pass. That's how I see it (transa2:2, my interpolation).

E1's understanding of the writing task, shown in the above part of the data, matched the tutors' expectations very well, as was proved by the mark she got for this assignment (67), and by the comments from her marker that she had a good "understanding (of) the nature of an academic assignment" (transst8:3).

With this understanding in mind, E1 identified three groups of readings she would need to do in order to write this assignment. Firstly, since she had little knowledge of doing research and writing a research proposal, and because this was a module on research methodology, she found that readings that can familiarize her with research design and research methodology were of primary importance. This understanding of hers was confirmed in an interview with a tutor while talking about the expected readings for this assignment: "for the research methods module, it's the methodology literature that they need to look at" (transst3:8). Secondly, she found that she needed to choose a particular topic related to education to base her research on, and she was asked to demonstrate her understanding of the chosen topic in the proposal by writing about the theoretical framework drawn upon (see appendix 8 for assignment guideline). Therefore, she needed to read on a particular subject of her choice in the area of education. Finally, as she had decided to use a questionnaire as a means of data collection, she would have to read on questionnaire design, which was a subgroup of the readings under methodology literature. In addition to learning about general principles of questionnaire design, she also felt it necessary to look at the literature in the chosen subject area in order to find research studies using questionnaires, so that she could get some idea of what kind of questions were asked in research studies similar to hers in one way or another, and how they were asked (transa1:28, transa2:1-3, 6, 10, 17). In the following parts, I will talk about each of her three groups of readings in turn.



### 6.2.1.2 Finding a Way into the World of 'Research'

As mentioned earlier (see 5.3.1.1 above), E1 considered the methodology module “very useful” as a course “introducing her into the world of research” (transa4:1). However, she did not like reading the textbook recommended by the tutors (transa4:1) because it was “full of abstract terms and concepts” (transa2:16). With the first assignment due in a few weeks' time and with an intension to learn how to do research, E1 did not delay in finding herself some other books on research methodology. There were two books which had played an important role in helping her form a general idea of how to write this assignment (transa2:15-18), and both of which were “found by accident”—“being on the same shelf where she was looking for some other books” (transa2:18). The following part of data shows how the two books helped E1 and how she read them:

这本书里面它会教你怎么样写，它会一部分一部分教，它会教你怎么样做那个，例如说 qualitative 怎么样写 introduction, quantitative 怎么写 introduction, …这部分, design research, 这部分, 这部分是最, 你看 the introduction, purpose statement, research questions, use of theory 其实就相当于 literature 那部分了。…你看它的 qualitative 的, quantitative 的, mix 的…例如是 qualitative 那么这种的 format 这种的怎么, 怎么布局, 先要写什么之类的…其实我觉得这些方法论…你写实际上肯定是不会写这些, 但是这个会指导你怎么样做, …这本书真的很有用, …七十几页都比较有用的。但是我中间会挑, 例如我是做 quantitative 的, 我就会挑, 还有例如说我是觉得 introduction 特别难我会重点看这部分, 其他的部分就略过了, …相当于细读加粗读, 大概翻一翻, 然后是有些重点部分会看。(transa2:15). …这本书其实刚开始我是准备按顺序看, …一直都看到这里了, 就按着顺序看的基本上就看到几十页了吧, …这部分特别详细的看, …这本书就说是, …就这部分, choosing your topic and developing the title, 这部分对我非常, 就对我那个题目我觉得很有帮助, 对我自己选题, 因为我就认为做那个 …研究最难的一点就是选定题目, …尤其是把这个题目, …缩小, 缩小, 再缩小。…这部分对我太有用了, 而且…确实这一章是我唯一完完整整, 从头到尾一个字一个字看过的, 这章, 怎么样选题目。

This book tells you how to write (a proposal), part by part. For example, it tells you how to write introduction for qualitative research and quantitative research. ... This part ... of 'design research' is most (useful). You see, 'the introduction', 'purpose statement', 'research question', 'use of theory—the literature section in my essay actually'. ... You see, qualitative (research), quantitative (research), mixed (methods) ... For example, for qualitative research, what format ... how should you structure (the proposal); what should you write first, what next ... Although in actual writing, you won't write about these things (i.e. you should start with introduction, then purpose, then research question, etc.), this book tells you how to write. ... This is a very useful book, ... up to here, about seventy pages. But I'm selective in reading. For example, I'm doing quantitative research, so I only read the parts relevant to quantitative research. And for instance, I feel the introduction is difficult, so I read this part closely, and went through the other parts quickly. So it's browsing plus intensive reading of

important parts. (transa2:15). This (other) book, I had planned to read it from cover to cover. I've read up to this far, ... dozens of pages. ... I've read this part ...of the book ...very closely—'choosing your topic and developing the title'. This part is very very useful for me in choosing my topic. ... I think the most difficult part ... of doing research is 'choosing your topic', and particularly 'narrowing down, narrowing down, and further narrowing down your topic'. So this part is really really helpful. ... And this is the only chapter (of the book) that I read from the beginning to the end, word by word (transa2:19, my interpolation).

The above part of the data seems to show that from the two books, E1 learned how to structure a research proposal, and how to write each part of the proposal step by step. In other words, as she read on, she encountered issues involved in each step of the research process and learned about how to deal with them. For example, she realized the necessity of choosing and narrowing down the topic before she could start with the research proposal; she learned that she should justify her purpose of the research and come up with good research questions; she learned how to justify her chosen method (Transa2:10); she learned about different types of sampling (transa2:19). In a sense, the process of reading was a process of obtaining knowledge about doing research and writing a research proposal, which was partly the intended module outcome and tutors' purpose of setting this assignment (appendix 7).

The above interview data also show that E1 was selective in reading, focusing on what she chose to use, e.g. quantitative research, questionnaire design, and ignoring the rest. She was also selective in the sense that she paid more attention to what she was not sure about than what she already knew, which was understandable considering the time pressure and work load. This seems to confirm a point I have made earlier (section 5.3.1.2 above), namely, that knowledge gained in the process of reading for writing assignment was not likely to cover every aspect of tutors' expected learning outcomes (see appendix 7 for specific course objective and outcome).

In short, reading methodology literature set the frame of the whole assignment: structure, sections to be included, what to put under each section, etc., which was also the 'object' that E1 was working at at this stage of reading activity. Another point worth

mentioning from the data just presented, which leads to the discussion in the next section, is that from reading the methodology literature, she realized the importance of choosing and developing the topic. Reading for choosing and refining her topic was an essential part in the whole process of reading and writing, which I will discuss next.

### 6.2.1.3 Choosing and Developing the Research Topic

E1's starting points in her assignment reading were personal interest and personal relevance. In the first interview in week two, she already started thinking about the topic for the first assignment, which she also hoped to develop into her final dissertation.

Her interest was as follows:

我是...就是对一些外国的学生,就是说中国的,或者说广泛一些叫 international student 到了英国这边, ...那么很多人过来,我就对这个话题比较感兴趣, 其实涉及到一些...这种叫什么 culture shock 这样的一种,到这边的不适应性这方面的...现在,我方向还没有确定,刚刚开始,就是具体往哪方面写我还不确定,但我主要想写这些外国学生到英国面临的一些问题,尤其是在高等教育,主要是在 post 这个阶段.因为我自己也是刚过来的,所以我对这方面,由于我自己很有感触,所以我对这方面,很有兴趣,想做。

What I'm interested in is something related to overseas students, Chinese students, or in a broader sense, international students who came to the UK. ... A lot of people come to study in the UK. So I'm interested in this topic, which involves something like a culture shock, or inadaptability to the new environment. ... I have no clear direction now. I've only started, so I don't know what exactly I am going to write about. My main focus will be the problems facing students coming to study in the UK higher education, at the postgraduate level in particular. I, myself, have just arrived in the UK recently, and have experience in this respect, so I'm interested in it and would like to do (research on it) (transa1:27-28, my interpolation).

Apart from that, the choice of her topic was also influenced by a sample writing of this assignment by a past student<sup>2</sup>, as she mentioned in the following part of the data:

我写这篇文章是受了我看的一篇范文的影响, ...它写的是 stress, teacher stress, 那我就想了,我现在为什么我不可以写学生的 stress 呢? ...而且我自己出来,我自己也觉得 very stressful 那种感觉的...

This assignment was influenced by a sample writing, which talks about 'stress', 'teacher stress'. I was thinking 'why don't I write about student stress'. ... I myself am studying abroad, and I feel very stressful ... (transa2:2-3).

Having had a rough direction of the research, E1 needed to identify the exact focus of it.

As she reported in a later interview, her "focus (of research) was developed through the process of reading" (transa2:3, my interpolation).

---

<sup>2</sup> The convener of the module IER circulated some sample writings by the past students.

First of all, she needed to find something relevant to read. She used the 'key word' search in the library catalogue to search such terms as 'culture shock', 'stress', 'international student', 'Chinese student' etc. (transa2:1). According to her, she explored almost every book related to culture shock and/or stress in the library; she checked all books that have something to do with her topic (or the key words listed above) (transa2:1). By reading them, she found that the concept of 'culture shock' involved many aspects, which might take her too much time to cover before she could write about it. And there were special terms such as 'acculturation', which were totally new to her (Transa2:2). So she decided not to focus on culture shock. Then she turned to the literature on 'stress', only to find that there was very little literature on it, and that no one has ever defined what 'student stress' was (transa2:3). As she read on, she discovered that:

阅读量大一点就发现为什么没有人去定义, 因为人家没法定义, 这个太广了, 这包括很多的, 例如说 financial stress, life stress, life stress 里面又包括很多很多种。There is no definition for 'student stress' because it is too big a term to give a definition to. There are different types of stress, such as financial stress, life stress, etc., and there are further subcategories of life stress and so on (transa2:3).

Having discovered this, E1 kept on exploring the books she borrowed on the topics mentioned in the previous paragraph, with a hope to further narrow down her topic. Usually, when she picked a book up, she first went through the table of contents to see if there was any chapter relevant to her research (e.g. stress, coping and adjustment) as she only intended to read the relevant chapters (transa2:4). After she decided on which chapters to read, she would have a look at the introduction or the summary to each of those chapters to see whether she should go on reading them in detail. As she said:

通过目录, 还有一些 summary 和一些 introduction 来...区别哪一些最重要, ...还有看每一章的大标题, 每一章的小节的标题。... 找到需要看的, 需要看的大章, 然后再在这个大章里面再粗看, 看看需要重点看的细节。

Through the table of contents, and summary and introduction, I can tell which parts are important to me. ... I also look at the title to each chapter and subtitles within chapters. ... After I decide on which chapters to read, I'll glance through the whole chapter to spot sections that need reading more closely later (transa2:5, 8).

During this process of screening and browsing, E1 accumulated knowledge in this

area and identified the exact focus of her research, which is evident in the following part of the data:

stress 刚开始我不清楚的, …stress 其实很多种类的呀, life stress, academic stress, financial stress, 很多种, 到底写什么, 我刚开始就只是很泛泛, 很朦胧的写了一个就是 stress. 而且也没有想到到底是 stress 的 outcome, 是 stress 的 influence, 还是 stress 的 reason 这些哦, 其实你可以写很多的. 后来我才最后确定, 对, 我要写 stress level, 就只是研究他们的紧张的这种到什么程度, 然后是和一些影响它的变量. …后来我…才就是终于觉得想到应该写的是 academic stress. …

I was not clear, at the beginning, what stress is ... Actually there are many types of stress, such as life stress, academic stress, financial stress, etc. There are many types, and I didn't know what exactly to write about ... At the beginning, I only had a vague idea that I was going to write about stress. ... I still hadn't decided whether I would write about the outcome of stress, the influence of stress, or reasons of stress. You had lots of choices. Then, finally, I decided I would write about the stress level, i.e. to what extent they (international or Chinese students) feel stressful, and the variables that influence their stress level. ... Later ... finally I found that I should write about academic stress (transa2:28, my interpolation).

Besides the books borrowed from the library, E1 also used online search engines such as 'Google', 'Find Articles', and e-journal databases such as 'Sage Publications' and the university library e-database to find journal articles (transa2:9), because she found that journal articles were more useful for writing than books, as can be shown in the following part of the data:

tutor 也说过 journal 其实是最有用的, 我现在也发现确实是这样的, 如果你查到, 能查到一篇核心的 journal 的文章, 比你查十本书都有用, 因为书毕竟太厚了, 二三百页, 你不可能, 你不可能说挑出一段来读, 你不可能, 你要可能读完全书才能够挑出里面有用的东西. 但 journal 就一篇才一两千, 才几千个字, 非常非常精华, 你看这题目就是, journal 里面真的是有用。

My tutor also said that journals are most useful (for writing), and I found that to be the case, too. One journal article that is essential for your writing may be more useful than ten books, because books are usually too thick, two or three hundred pages and it is not very likely that you could pick out the section that is useful to you, unless you finish the whole book. Whereas a journal article is perhaps only a couple of or a few thousand words, very condensed. Just look at the title, you'll see it's really useful (transa2:4, my interpolation).

She downloaded articles to her computer and sorted them into different folders according to their topics, such as 'stress' folder, 'international student' folder, 'questionnaire design' folder, and further separated more relevant articles from less relevant ones into different folders (transa2:12). Before she downloaded them, there was a selecting process, as she described as follows in an interview:

我就是首先看它的 introduction 或者它的 abstract, …我觉得没什么用处的…把这篇就删掉了. 然后看… abstract 或者说是那个 summary 或者说是 introduction 比较吸引我的, 我觉得挺有用的, 我会把它…放下来, …然后就把这篇都 scan 一下, …就特别好的我就把它作为精品留下来, 然后不太好的放在另外一个文件夹里。

I first read the introduction or abstract, ... If it's not useful ... I'll delete it. If the abstract, or the

summary, or the introduction attracts me, or I find it useful, I'll download it. ... After that, I'll scan the whole article, ... and put the most relevant ones in a folder, and put those less relevant ones in another (transa2:12).

Up to this stage, E1 had got hold of most reference materials she would be using in the subject area of academic stress for international students from various resources, though she might not have read most of them in great detail. The process of searching, browsing, and selecting relevant readings was also a process of thinking that helped her develop the focus of the proposed research, and find appropriate justification for doing this research, which constituted the 'object' of her reading activity at this stage. Next I will turn to the process involved in reading for designing the research study data collection instrument.

#### **6.2.1.4 Learning to Construct a Questionnaire**

As was mentioned in 6.2.1.1 above, when she interpreted the writing task, E1 had already figured out that a well-designed data collection instrument (in her case, a questionnaire) was an indispensable part of a good research proposal, without which the research cannot possibly serve the researcher's purpose or answer the research questions. The research methodology literature again played a role here, by familiarizing her with the principles of questionnaire design. In addition, she searched for some questionnaire samples in the Internet to get an idea how others design them, though the samples did not necessarily have anything to do with 'stress' (transa2:8). For example, she learned how to write a cover letter that usually precedes a questionnaire; she learned certain ways of designing questions and the options for answers, such as asking the respondent to choose an age group rather than write down the exact age (transa4:30-31).

E1 also found that most studies of 'stress' used a questionnaire as a means of data collection, including quite a few studies on academic stress (transa4:31). Among those studies, there was one about academic stress level that was very relevant to hers, in

which the author used an 'academic stress level inventory'. She decided to adopt the inventory as part of her questionnaire (transa2:13). However, she could not understand how this inventory worked, because the author only listed the inventory at the end of the article as the instrument for his research without explaining the theories behind the inventory. According to the reference in that article, she tried to search, by various means, the key words—'academic stress level inventory', and managed to find an article, via Google, which explained how to use this inventory (transa2:13).

From the ways in which she handled this group of readings, it seems that E1 knew not only what readings may help her design the questionnaire, but also how they may help her in different ways. She also showed her skilfulness in combining different means of searching for readings (e.g. use of reference list of a certain reading to further explore relevant readings, use of various search engines or databases in search of something she did not know for sure where to look for, etc.). Next I will turn to the final stage she went through in this context, i.e. integrating reading into writing.

#### **6.2.1.5 Integrating Reading into Writing**

The previous sections on the stages of E1's reading seem to show that the activity of reading cannot possibly be separated from writing, because she always bore in mind the writing task while she was reading, or in other words, her reading was almost exclusively to serve the purpose of writing the assignment. The three groups of readings were approached in different ways according to the different purposes they served in the writing.

First of all, E1's reading of the methodology literature played a crucial role in her writing, providing her with a general framework (transa2:17) to structure her writing. She read them in a very careful way, taking notes as she read along to help her understand (rather than quickly browsing them and went back only when she needed to

quote or cite). Yet the importance of such literature was almost invisible in her list of references that she included with her assignment because she did not quote from them—only one out of the twelve entries was a book on research projects, from which she quoted to support her choice of questionnaire as the means of data collection, (transa2:17). However, in another sense, reading of this part of the literature was visible throughout the whole assignment—her understanding of the research literature was visible in the way she structured the proposal, put forward the research questions, and arranged her arguments, in the coherence she demonstrated in the whole piece of writing, and so on.

Reading in the topic area, i.e. 'stress', was more visible in the writing compared to the methodology literature. According to E1, most of the literature she used comprised online journals—five out of the twelve entries in the reference list (transa2:11). While she was reading online journals, she usually made notes (ibid), copying down sentences that might be used in her writing as she read on (ibid). She further described the way she read online journal articles and made notes:

有时候是交替着看，…假如这三篇文章都是关于 stress 的，…觉得这几篇有用…我看完这篇…然后我就会跳到那一篇，再看一看，然后再几篇比较一下哪个最好，…就有横向的，也有纵向的，纵向是整篇文章，从头到尾，看到尾，哪句有用抄下来，哪句有用抄下来。

Sometimes I read several articles at the same time. For example, suppose there are three articles about stress here, all of which I found useful. After I finished reading one, I would turn to another one ... and then compare among them to see which (arguments suited my purpose best). ... Or in other words, I made comparisons 'horizontally', i.e. across different articles to find the most suitable things to note down. I also made comparisons 'vertically', i.e. reading through one article from the beginning to the end and noting down useful quotes wherever I saw them (transa2:13, my interpolation).

Although she made notes while she read both groups of readings mentioned above, the purposes of note-taking, hence the functions of the readings for writing were totally different. Judging by the notes she took and her comments in the interviews, when she read methodology literature, the notes were summaries of the main points that helped her understand what she read; whereas for the 'stress' literature, she focused more on details that could support her arguments (mostly justification for her choice of the topic



area, choice of her research focus, etc.) in the writing rather than on main ideas of each piece of reading.

As for the literature on questionnaire design, E1 looked at research methodology literature for guiding principles for questionnaire design, and this reading functioned in a similar way as the research methodology literature did for the whole piece of writing. She also consulted quite a few questionnaires designed by others for studies either relevant or irrelevant to the area of 'stress'. She sometimes adopted the exact questions as part of her questionnaire, sometimes modified the questions slightly, and sometimes developed new questions inspired by the samples (transa4:30-31). E1 did not start writing until it was a week before the deadline, when she felt absolutely ready to do so (transa2:28-29).

#### **6.2.1.6 Summary**

Having discussed the different types of readings and different stages in E1's reading activities for writing her first assignment, it is worth pulling everything together by a discussion of the construction of the 'object' over the whole process of the reading activities.

As reading especially for the purpose of writing, the process started from the writing task, and ended at a point when reading was integrated into the final written work. Before she started any reading, E1 analysed the writing task in order to identify possible readings she needed to do for successful fulfilment of this writing. On the basis of her understanding of the assignment guideline and a sample writing of a past student, she decided to undertake three groups of readings that she thought essential for writing this assignment. She approached the three groups differently according to the different purpose that each group would serve in the writing. For instance, she read the methodology literature very carefully, making notes as she went along, with the aim of

getting an idea of how to structure a research proposal, and what usually can be put under each section. Also related to the methodology literature was part of the readings for questionnaire design, from which she was looking for both arguments to quote/cite in support of her choice of the questionnaire over the interview as the means of data collection, and principles of questionnaire design to guide her in developing questions. The other part of this group of readings, i.e. questionnaire samples, served both as a stimulus for creating new questions and as a bank of questions from which she could choose and adopt some questions to form part of her own questionnaire. On the other hand, from the 'stress' literature, she gained not only understanding of this topic area, but also supporting arguments for her choice of the particular area of research. The notes she made for this group of readings were points that she could actually quote/cite in her writing, which served a different purpose from the notes she made for the methodology literature.

Whatever type of reading activity she was doing and whatever purpose it served, the overall 'object' of the whole process was to gain adequate understanding of the relevant areas and sufficient ideas to form arguments so as to produce a successful written work for assessment purpose. Of course, this 'object' was not all clear at the beginning of the activity. Instead, it evolved gradually and became more and more obvious during the course of E1's reading activities. For example, at the beginning, E1 knew that she needed to choose a subject area and she had a vague idea that she was interested in the life of international students studying in UK universities; yet she did not know exactly at that time what the topic would be and how to justify her choice of it, which she managed to clarify during the course of reading the 'stress' literature. Before reading the methodology literature, she already knew what she was required to write was a research proposal, but she did not have a clear idea what it might look like and

how to construct it, which again got clarified through reading. The emphasis of her reading activities at different stages differed from each other (e.g. at one time, she focused on identifying relevant literature, at another time, she focused more on questionnaire design, etc.). She was often doing more than one type of reading activity over the same period of time (e.g. she was reading methodology literature, searching the Internet and searching the university library catalogue for books and articles on 'international students', 'stress', 'culture shock' etc., and reading 'stress' literature at roughly the same period of time). Despite the shifting emphasis of her reading activities from time to time, and the varying goals of different type of reading activities, she was working towards the same ultimate 'object'—gaining understanding and generating ideas via reading in order to produce a satisfactory piece of writing.

### **6.2.2 Tutor's Comments vs. E1's Reflection on Her Reading and Writing**

This section focuses on the tutor's feedback on E1's assignment, on the one hand, to see how well E1 met the tutor's expectation. On the other hand, I also focus on E1's reflection on her reading and writing (to see whether there was a gap between her view and her tutor's on her reading and writing), and her understanding of the tutor's comments (as this is also a type of reading practice which may very likely influence E1's later academic reading and writing practices).

In an interview with him, E1's marker of this assignment thought quite highly of her work, saying that:

[S]he looked at the relevant literature, (in a) quite ...appropriate way. And then that ...this area not being particularly well researched before, so she built a case for why ...she looked at this particular area. And then the design and the exploratory nature of the research looked appropriate, and that was quite well worked out. ...I think you know, overall it was just quite well done. I mean it ...was ...well structured; it had a clear focus; and there was a good argument for undertaking it; and so on. ...which enabled me to give ...quite good mark, which was this ...upper sixties (transst8:3, 6, my interpolation).

These comments seem to confirm E1's understanding of the assignment that the proposal should be logically and coherently designed and have good research questions

(see 6.2.1.1 above). They also confirm that E1 had identified the right types of readings and had used the readings in an appropriate way. E1's reflection on her assignment echoed, to some extent, that of her marker's:

觉得写的肯定是比较规范的，…肯定是按照它的要求写的。…肯定是没有跑题的，而且…我觉得那个…research questions 还算是比较的切合题目吧，…我觉得选题还可以。  
(I) think I have followed exactly the requirements of this writing task. ... I have not missed the point of the task. Besides, the research questions are appropriate to the topic ... and the topic is well chosen (transa3:1).

However, E1 and her marker did not always agree with each other on some aspects of her work. There were indications that they sometimes misunderstood each other. For example, E1 thought that one of her weaknesses in the use of literature was that she almost always quoted the exact words from the source. And she thought it might be better if she could have paraphrased them. She admitted that as she was lazy as well as short of time, she just copied the exact words to her work (transa3:2). Judging by the appearance of her work, her marker disagreed with her, remarking that "she didn't use that many quotes. ...As I said, you know, where she did use, they were quite effective". (transst8:8). Such mismatch in understanding may have resulted from their different understanding about the correct referencing.

Another example of the disagreement and misunderstanding between E1 and her marker is concerning one of the marker's comments, which goes "you may also need to be aware of the types of stress that seem to be experienced by different groups, not just levels" (see comment 3 in appendix 9). E1 did not quite agree with this comment, or to be more exact, she did not see the marker's point in making this comment, as she said in the following part of the interview data:

我本来就明确的，就 academic stress 嘛，academic stress 还能有什么种类呢？我这点真的不明白。…我当时就是觉得很迷茫的，拿回来的时候，…我在这儿提到过一句 stressor 就是导致这个烦恼的因素有什么什么 academic, financial, time…如果我的 question 里面是针对…就是 academic stress, 如果我 question 里面再涉及到其他的话那就不不伦不类了嘛。…那除非就只能理解成他就是说 academic stress 还有很多种类，但是据我这种很浅薄的阅读量来说我还没有反映出来……他是不是区分…academic stress 包括有什么，例如说是那种由于你文理科不同，而导致的不同什么之类的。…难道 stress, academic stress 还有，还分很多种类吗，我就是不明白。这个问题我不明白，

说实话. 他提这个我觉得很模糊。

I clearly stated that (my focus) is academic stress. Can there be different types of academic stress? I didn't understand this comment. I was confused when I first looked at the feedback after I got it back. ... I mentioned here the stressor—the cause of stress—can be financial, academic, time, or something ... If the focus of my (research) question is on academic stress, it would be weird to mention other types of stress. ... Or the only alternative explanation is that he means that there are subcategories in academic stress, but I could not think of any from the limited reading I have done in this area. ... Or does he mean that academic stress includes something like ... for example, science students and arts students may have different types of academic stress due to their subject areas? ... Could there be many different types of academic stress? I really don't understand, to be honest. His comment is very vague (transa3:5, my interpolation).

The interview with the marker revealed that he thought there could be different types of academic stress:

The problem here ... was that she just talked about levels of stress, so the way you discuss stress ... was just a matter of ... how much it was. ... Now I was saying that ... there are lots of different types of stress ... not just a matter of how much, ... to what extent do international postgraduates feel academic stress; how do variables ... influence levels of the stress of international students. But I would thought that gender, age, and nationality might ... create a situation where there, ... it was not just a matter of how, you know, whether people were very stressed, small amount of stress, or no stress. But the different types of things will create different types of stress. ... So that you could be stressed for example, if you are an international over ... over your level of language fluency, ... which could create all kinds of issues for you, like it meant you work, you could only work at a relatively low, slow pace because you are trying to do ... you have to take time to read things. So you got that kind of issue. If you are a female student rather than male student then maybe issues associated with academic stress in this is gender related. I don't know what they might be for now, but do you see what I mean. So I ... just think that stress is not generic, it's situated, ... so it was that point really. ... I mean level ... is just, level would be just one way ... of understanding stress. ... What is just as important are the kind of sources or different types of stress. You know, if it's to do with time, if it's to do with capability, it's to do with language uses, if it's to do with social things, if it's to do with emotional issues, and so on (transst8:7).

The marker's explanation in the above part of data has shown quite clearly his reason for making this comment in the feedback sheet. E1's confusion about the comment arose from the simpler and vaguer expression of the comment in its written form. In other words, E1 experienced some difficulty in reading the tutor's comment. Although reading tutor feedback is not as central a type of academic reading practice as some others, failure in such reading practices also causes problems in students' academic reading and writing experiences. E1 could have asked the marker to clarify his comment. She did not do so because (personal communications, April 2005) firstly, she was not the kind of person who was very keen on trying to do one's best for everything, which was evident in her attitude towards study during her undergraduate years (see section 4.2.4 above). Secondly, she had a lot of new assignments to do in the second

term, which left her almost no time to attend to the comments for her previous assignment, especially when the assignment was not directly related to future assignments. When she talked to the marker about another assignment she would be doing in the future, she totally forgot to ask the marker about the comments that she did not understand, which showed that it was not her priority. Thirdly, the assignments that followed were very different from her first one, so that she could not easily draw upon her experience and the tutor's comments concerning her first assignment.

Seemingly, E1 did not get much out of the feedback from her marker, because what she already did well in her reading and writing was confirmed by the marker as good aspects, which she would simply continue with; whereas, on the other hand, with respect to the area that the marker would like her to improve, she did not see the marker's point very well, nor did she agree with him. However, this does not mean she felt she had not benefited from the feedback altogether. She reported that

首先我觉得最大的启发就是说是, …你假如说你真想做一个研究人员, 首先你不能 bias, 不能太 subjective, 就这样显得太难以服…, 还有就是关于文章的严谨性, 例如说不管你 adopt 的任何东西, adapt…你都必须要放…这样说过之后对我的就是意义挺大的, 尤其是关于那个 subjective 的那个, 以后会要尽量做到稍微客观一些。

The most enlightening point (in the feedback) is that as a researcher, if you really want to be a researcher, you must not have bias<sup>3</sup>; you must not be too subjective, otherwise you (or your research) won't be convincing. Besides, you need to be rigorous with your writing. For example, whenever you adopt or adapt anything, you have to give (the original to show how you've changed it). This is a valuable comment<sup>4</sup>, so is the one on subjectivity. I'll try to be more objective from now on (transa3:8, my interpolation).

This part of the data shows that she considered these two comments in her marker's feedback as the most valuable ones for her future writing and research. Comparing E1's views in the part of data quoted above with the marker's opinions expressed in the feedback (appendix 9) and in the interview (transst8:7-8), it seems that E1 fully accepted the marker's comment on the research instrument. However, what she learned

<sup>3</sup> Comment 5 from E1's marker: Subjectivity is more or less always present in research instruments if you mean 'bias'. In questionnaires it is present in the order of questions, the choice of questions, the weighting of variables etc. (appendix 9).

<sup>4</sup> Comment 5a from E1's marker: Make it clear that the instrument is in the appendix and the extent to which it has been adapted (appendix 9).

from the comment on subjectivity seems somewhat different from what the marker intended to convey. In her writing, E1 argued that “an interview ...is highly subjective and therefore there is always the danger of bias”, implying that a questionnaire was better than an interview in this respect. Her marker pointed out that questionnaires can also be subjective (see footnote 3). On seeing this comment, what came into E1's mind was that the marker was criticizing some of her expressions as being too subjective, as she also admitted in an interview that her writing was a bit naïve, and the tone was a bit subjective; she also found in her writing quite a few expressions like ‘I'm sure’, ‘overwhelmingly’, etc. (transa3:1). Nevertheless, despite the misunderstanding that occurred, it should be noted that E1 did identify problems in her writing and conceptualisation and was therefore in a position to avoid them in the future. This example also seems to show that tutors' comments on students' assignments, whether fully understood by the students or not, may influence the students' later academic literacy practices in some way. Therefore, the reading of such comments is also important for the students' academic studies.

Part of E1's interview data shows that her partial misunderstanding of the marker's comments arose because she did not know how to read the comments (transa3:4). The marker described the process of marking as follows:

First of all I check the assignment briefly, so I understand exactly what's their main style. Then I read through the assignment, and I have a number of, broad criteria that I might also use to do with the structure and the substance, the extent to which literature was referenced, the coherence overall, the writing style, sophistication of the use of resources, theory and evidence or anything like that. So I have these criteria, which we agreed in the past to do with the MA. Then I make specific observations of aspects of the text as I go through. And I give those a number, annotated number so the 1, 2, 3, 4, 5, 6. Sometimes I write on the script and sometimes I don't. Then when I write my final comment, I write a general comment, which deals with structure, the things I've just mentioned, referencing, theory, coherence, originality, all those things. And then I use the annotated list underneath, which refers to these comments, number 1 within the text would refer to number 1 comment here, and so on (transst8:1-2).

Therefore, each one of the comment referred to a specific place in the text, rather than to the whole text in general. E1 was not aware of the function of the annotated list (transa3:4), and did not know those comments referred specifically to certain places in

her writing. Instead, she had thought those comments referred to the whole assignment in general. As a result, she could not always get the points that her marker intended to convey. Lack of understanding of the usual practices (e.g. the conventions of tutor comments) in the UK university setting caused some problem in E1's reading. Thus, although such reading of tutor comments does not constitute the central part of students' academic reading, it can nevertheless also be essential to their academic studies.

In short, the marker said that he "thought overall it was a pretty good piece of work ... and (the proposal) could be used straight away (transst8:9). This shows that E1 had a good understanding of the reading and writing task for this assignment and dealt with the reading of academic texts (the central type of academic reading) for the purpose of writing well. This also shows that she was able to adjust herself fairly quickly to the new learning situation and find effective ways of dealing with the assessment requirements. However, the marker's feedback could not fully play the role that the marker would like it to as E1 had difficulty interpreting the comments, once again showing the importance of this type of academic reading. Practically, it may be more difficult to give students guidelines for reading the feedback sheet than those for doing the assignment due to the fact that tutors have their own preferences in doing comments. And it seems quite unusual for markers to give guidelines for reading comments in each individual feedback sheet as I have not seen any feedback sheet with a guideline so far both in my experience as a student and as a researcher. Students might also be unlikely to ask their markers for clarification, as none of my interviewees in the MA in Education programme consulted their markers while they did have some difficulty in understanding the comments (some reasons for this have been mentioned earlier in this section). With few students asking questions about the comments, tutors may assume that the students can understand them, because tutors may usually think



that at the MA level, students are supposed to take more responsibility for their own learning, and should approach the tutors whenever they have any problems (transst1:8-9, transst2:3, transst3:6). Therefore, it seems that the students may cope well with some types of academic reading but not others, and lack of communication between the students and tutors prevented the students' problems from being discovered and solved.

As a whole, the discussion of E1's case here has revealed the details of the reading experiences while writing an academic essay from one Chinese student's point of view, and has demonstrated the ways in which the theoretical framework established in Chapter 2 can be applied to the data of this study. In the following part, a similar analysis will be carried out from another subject's perspective, so as to reveal possible commonalities and differences between different subjects.

### **6.3 E2's First Assignment**

Here, I will discuss, in detail, different aspects in E2's reading practices for writing her first assignment for the IER module. This will include consideration of the whole process of reading and writing from choosing the topic to finally composing the assignment, tutor's feedback, E2's reflection on her reading and writing and her comments on tutor's feedback. Comparisons and contrasts between E1 and E2's experiences will be made, and possible causes for their similarities and differences will be explored.

#### **6.3.1 The Process of Construction of 'Object'**

This section presents the specific process of E2's reading practices for writing her first assignment for the IER module. This process basically involved four stages: the choice of a topic, identification and search for relevant literature, actual reading of the literature and deciding on the uses of the literature, and integrating reading into writing.

### **6.3.1.1 Choosing the Topic—a Choice out of Convenience**

The topic that E2 was working at—novice teachers' dilemmas and advantages—was not developed by herself, but was designed by her tutors and given to her as part of her practice teaching project as a student teacher during her undergraduate studies in China. According to her, she was not familiar with this topic even though she had written about it before, because at that time she did not search for the relevant literature or existing research studies, nor did she study the techniques of interviewing<sup>5</sup>. It was simply a topic that she could use for the IER module assignment (transb2:1). Therefore, the topic for her IER module assignment was a choice out of convenience rather than out of careful consideration. Thus she made up her mind of a topic much earlier than other students, and saved much time.

### **6.3.1.2 Identifying and Searching for the Literature**

Although she already decided on the topic, E2 hardly had any idea how to write the assignment, as she put it in one of the interviews as follows:

这里学的东西我觉得都一带而过，大部分叫你自己弄的嘛，所以我想了这个题目之后其实我也不知道应该怎么写 research proposal 的。

What gets taught here is usually mentioned so briefly in the sessions that one almost always has to learn it by himself/herself. So, after I thought of the topic for the research proposal, I still hardly had any idea as to how to write it (transb2:1).

Fortunately, a sample essay written by a past student was distributed to them, and the tutor also provided assignment guidelines (appendix 8), on the basis of which E2 was able to identify the readings she needed to do and to learn about the structure of the proposal (Transb2:1).

The sample essay was one of the readings she read most closely (transb2:2-3). She followed its general structure: from the purpose of the research, theoretical framework,

---

<sup>5</sup> She nevertheless did make use of interviewing to collect data at that time (transb2:1).

literature review of the existing research, to the choice of methodology<sup>6</sup> (transb2:3). Thus she came to realize that there were three groups of readings she needed to cover: firstly, she needed to read in the relevant subject area in search for theories and justification for her research; secondly, she needed to read research methodology literature to be able to design the research using the method of her choice—questionnaire; thirdly, she needed to read both in the subject area and the methodology literature in order to design a good questionnaire (transb2:1-3).

Among the references she used for this assignment, one was the course book for the module; a couple of books were recommended reading from the further reading list (e.g. a book on 'how to research', a book on questioning, transb2:3-4); the rest was found by herself. She usually used 'key word' search in the library catalogue to look for the literature on the subject area or to locate books recommended by her tutors (transb2:3, 6). Some of the books were found by chance<sup>7</sup> (transb2:3, 6). At the beginning, she only searched for books because she did not know how to search journals (transb2:7). After consulting the subject librarian, she learned to search journals in the library e-database. Later on, the librarian also did a session on how to use the library for all students in E2's programme, and E2 felt she was able to understand the session better than some of her course mates because she already knew something about it (transb2:7). Again, she often used the 'key word' search for journal articles.

### **6.3.1.3 Reading**

She usually read in the library because there were too many distractions in her study bedroom which made her unable to concentrate on reading (transb2:9). First of all, she

---

<sup>6</sup> Both E2 and the sample essay used questionnaire as the means of data collection.

<sup>7</sup> For instance, one of the books was in the same row as the one she was looking for but could not find, so she took that book instead (transb2:3). Another book was on the shelf behind her when she was reading in the library. When she turned her head, she saw the book and found it quite useful (transb2:6).

screened what she had found. For journal articles, she would first have a look at the introduction to decide whether she should read it in detail or not; for books, she would glance at the relevant parts to see if they were really relevant to her assignment, and return those irrelevant ones immediately (transb2:2-5, 17).

E2 approached differently the three groups of readings (i.e. the literature on research methodology, on the subject area, and on questionnaire design), which served three different purposes. And even within each group of readings, she did not read everything in the same way. In the research methodology literature, the course book was read most closely. She read the 'research design', 'sampling' and 'methods of data collection - questionnaire' sections in the book very carefully. The questionnaire section in particular was read sentence by sentence, and she made very detailed notes (transb2:2, 11, 17). There were another two books on 'how to research' that she read quite briefly<sup>8</sup>. In one of them, she read the 'questionnaire' section for the advantages of this method. In the other, she consulted the 'use of theory' section, which was illustrated by examples, to get an idea of how to write the theory part in her proposal (transb2:3).

The second group of readings, i.e. the subject area ones, were mostly journal articles, among which there were two she read carefully, and there were another three or four articles that she read the introductions only (transb2:17). An article on the 'Novice Teachers' Dilemma' was read, sentence by sentence, from the beginning to the end, with only one section about the 'senior teacher' being skipped over, and notes were made on this article in great detail to help her write a summary of it to go into the proposal (transb2:13, 18). Another article read in the same way was one on 'teacher's professional identity', whose theory section she read very carefully in order to write the theory part in her proposal (transb2:18-19). The other articles that were read less

---

<sup>8</sup> She had already read the course book in great detail, so she thought it unnecessary to read these two carefully (transb2:2, 3).

carefully served various purposes in the proposal: for example, one of them, which looked at teacher development from a philosophical perspective, was used as part of the existing research; another one about teachers' roles in the development of a school was used to prove the importance of her research (transb2:10).

The last group of readings included both research methodology literature and subject area literature. The course book for this module, which she read very carefully, provided guidelines of questionnaire design; and another research methodology book showed her more concrete types of questions (transb2:3). Concerning the specific content of the questionnaire, one book about 'how to be a good teacher' was particularly useful to her (transb2:5). This book talked about good teachers' characteristics, how good teachers prepare lessons, manage lessons, etc. and how to self-assess whether one is a good teacher or not (transb2:5). The main aim of the questionnaire was to assess how well novice teachers do in the following four aspects: lesson planning, lesson management, student-teacher interaction, and psychological adjustment to the new working environment (transb2:4). Therefore, E2 read some chapters in the book carefully, trying to think of questions she could ask in the questionnaire. She did not make notes this time. Instead, she wrote down questions that popped into her mind as a result of the stimulation by the reading (transb2:4, 5).

In short, different readings serving different purposes in the research proposal were read in different ways. E2 usually made notes while reading (transb2:13). She used two ways of note-taking: noting down main ideas as she usually did while doing pre-reading, or noting down only what she would like to quote or cite (transb2:17). Only at a later stage of the whole process of doing the assignment, after she started writing, did she stop making notes while reading, due to time constraints. Instead, she quoted or cited into her writing directly, or noted down the page numbers (transb2:12).

#### **6.3.1.4 Integrating Reading into Writing**

The previous section (6.3.1.3 above) has already shown some evidence of the differentiated treatment of readings by E2 according to the use she made of them in her writing. Here, I will talk about the details of how these various kinds of readings were integrated into writing by E2.

First of all, the structure of the whole assignment came from her reading of the sample essay by a past student together with the tutor's assignment guidelines. As was mentioned earlier (see section 6.3.1.2 above), she read the sample essay very carefully. In her own writing, she followed the overall structure of the sample, and imitated the way each section was constructed (transb2:3). The course book that she read very closely provided her with the understanding of research design and questionnaire design. It played a crucial role in this assignment, though it was seldom cited/quoted in the actual written work.

Given the purpose of the literature in the subject area, i.e. to provide justification for the research, to discuss existing research on the topic, to form the theoretical basis of the research, etc., it was not surprising to see, in her writing, more quotations or citations from this group of readings. E2 read and made notes of the readings differently depending on how she would put them into her writing. For instance, when she needed to put a quite detailed summary of an article in the proposal, she read sections in three to four articles almost sentence by sentence and made notes of all the main ideas as she did for the pre-readings (transb2:13, 17). If she only wanted to mention a reference as the existing research being done before, or to quote/cite a sentence to support her argument, she would just browse it and note down the particular point or sentence (transb2:10). While she was writing, she usually summarized or paraphrased the notes she made earlier (transb2:13, 17). If she encountered something that she was not sure how to

interpret precisely, she would quote it verbatim (transb2:16).

While designing the questionnaire, the methodology literature helped her get familiar with questionnaire organization, types of questions that she could use, wording of the questions, structure of covering letter, etc. (transb2:3, 12); whereas the subject area literature helped her construct suitable questions that would generate appropriate information for her research (transb2:4, 5).

While she was writing the assignment, she did not write it part by part in a sequential order, i.e. from the introduction right through to the conclusion. Instead, she first wrote the parts that she was certain about how to write, and saved the parts she was less certain about till later (transb2:2). After the 'introduction', 'purpose of doing the research', and 'review of the existing research', there was a section on the 'theoretical framework for the research', which she did not know how to write. So, since she already decided to use a questionnaire, she jumped to the research design parts first, which included reasons for choosing this method, research procedure, and so on. Finally she started designing the questionnaire, by which time she had got some help from her tutor concerning the 'theoretical framework'. Therefore, as she was working on the questions for the questionnaire, she was also reading and writing the theory section (transb2:2-3, 7-8).

### **6.3.1.5 Summary**

As the term 'reading for the purpose of writing' indicates, the overall 'object' of E2's 'reading for writing' was to produce a piece of written work on the basis of her reading activities. Although she had a vision of this overall 'object' at the beginning of the whole process of doing her first assignment, E2 could not possibly know what and how exactly she was going to read to fulfil the writing task until she was actually working on it. For example, only after she looked at the sample essay written by a past

student and the writing guidelines from the tutor did she realize that there were three groups of readings that she needed to do (see 6.3.1.2 above for details). Some of the references were given by the tutor so that E2 did not need to search for herself. For others, she had to search and then screen the results to decide the exact readings to do. For still others, i.e. references for the 'theoretical framework' in the proposed research, she even did not know what to look for. Fortunately, she consulted her tutor by email, and got a satisfactory answer, which directed her search for the relevant literature without wasting too much time in looking around and wondering about the relevance of what she came across. During the course of reading, it became increasingly clear to her how she could use each piece of reading in the writing, hence she read them differently depending on their potential uses, and made notes in different ways accordingly (see 6.3.1.3, 6.3.1.4 above).

At different stages, she focused on different activities—for instance, she read the methodology literature at one time, and worked on the subject area literature at another time; she read about the theories at one time, and read about questionnaire design on another occasion. Sometimes, the fulfilment of one activity was the prerequisite for the next activity—for example, analyzing the writing task led to the recognition of relevant literature; searching for relevant literature must be done before actual reading started. All in all, various activities all served one purpose, i.e. the construction of the 'object' of 'reading for writing'—getting E2 ready for satisfactory production of a piece of written work through reading activities.

### **6.3.2 E2's Reflection vs. Tutor's Feedback**

Looking back at the experience of completing her first assignment, E2 summarized a few points that made the process of writing smoother (transb5:1). Firstly, she had the sample essay written by a past student, who had also used a questionnaire as the means



of data collection, to help her structure and organize the whole assignment. Secondly, the writing requirements from the tutor also clearly set the expected content for each section, so that she did not need to think hard about what to write. Thirdly, she asked a tutor about the theoretical framework for her research and got a very useful answer, which directed her to the right path for searching relevant literature. Fourthly, she used the topic that she had used in her undergraduate years and thus saved much time in deciding on the topic. Moreover, she was lucky enough to find some references that suited her topic very well. Finally, she had very convenient channels of data collection<sup>9</sup>, which also helped her doing the second assignment task for the same module (transb5:1). In general, she was satisfied with this assignment and was sure she would not fail it: as she put it, “if this one fails, I am afraid I am not able to produce any work that passes (transb5:1)”. However, she was also aware that her work was not good enough to get a ‘distinction’, because there were no original or novel ideas, nor was the writing absolutely well-knit. She also felt that the questionnaire also had much room for improvement (transb5:1).

Therefore, the tutor’s mark<sup>10</sup> more or less met her expectations (transb5:1). Some of the tutor’s comments also confirmed E2’s opinions about this assignment. For example, the tutor remarked, “A good piece of work. You’ve done a useful range of reading, and have hit on professional identity as an appropriate organising concept. You’ve devised a sensible strategy for sampling, building on your existing range of contacts” (appendix 10).

In terms of the tutor’s criticisms, E2 agreed with most of them, and explained

---

<sup>9</sup> Her undergraduate course mates were mostly school teachers, who were able to be respondents themselves, and who could also distribute more questionnaires among their colleagues to enlarge the number of respondents (transb5:1).

<sup>10</sup> She got 60, the minimum mark in the ‘good pass’ category according to the Faculty of Arts and Social Sciences marking criteria for the master’s level assignments (appendix 15).

various causes for not being able to do better while writing the assignment. For instance, one of the tutor's comments went, "while your referencing is generally good, there is the odd blooper, probably caused by lack of familiarity: e.g. there is no such author as 'Judith, B' (appendix 10)". E2 was quite surprised to see herself make such a silly mistake<sup>11</sup> since she had paid special attention to referencing (transb5:2). She believed this was very likely a slip of the pen out of haste because she would not usually confuse first names with last names (transb5:2). Another criticism was concerning the length of the questionnaire<sup>12</sup>, as the marker commented,

Take care not to let individual questions run over more than one page. ... I particularly liked your draft covering letters, which struck me as likely to persuade folk to answer what is a moderately long questionnaire. Enclosing an evaluation form as well might be going just a little too far though! (appendix 10).

E2 attributed this to her lack of experience in questionnaire layout. After she rearranged the layout, there were only three pages of questions, excluding the evaluation form (transb5:2, 4). The tutor also pointed out that "I presume you are going to administer your questionnaire in Chinese. You should, therefore, give some consideration to issues connected with translation and cross-cultural understanding" (appendix 10). E2 explained that she had thought about this issue, but did not know she should mention it in the assignment (transb5:2).

There was also one criticism about which E2 had a different opinion from the tutor's, which seems likely to have resulted from E2's incomplete understanding of the tutor's comment. The tutor questioned her about "the evidence of believing that questionnaires produce more truthful and reliable answers than interviews", whereas E2 just emphasized her own unsupported belief in this being the case in the writing and also in the interview with me (transb5:3). It could be that she did not know what counted as evidence from the tutor's point of view, as it is not possible to know the tutor's opinion

---

<sup>11</sup> As she put it, this is like "having shipwreck in the sewer drain"(阴沟里翻船), meaning failing in a very easy task (transb5:2).

<sup>12</sup> The questionnaire plus evaluation form was 11 pages in length.

about 'evidence', in this case, as the tutor declined to be interviewed.

There was still another comment that E2 was not sure about, in which the tutor said,

I also liked the way you sought to draw your questions out of the literature. I wasn't so sure how closely some of them were linked to the issues you wanted to research, but they should provide useful data related to them. (appendix 10).

She did not know whether this was a compliment or a criticism, i.e. whether the tutor thought the questions were able to provide useful data or the questions should be improved so that they could provide useful data (transb5:2, 3). Despite the difficulty in understanding the comments, she did not bother to ask the tutor for clarification<sup>13</sup>. The two cases of E2's confusion about the tutor's comments seem to indicate that like E1, E2 coped well with the central type of academic reading (i.e. reading of academic texts) and experienced some problems in the more 'peripheral' type of academic reading (i.e. reading of tutor comments). Unlike E1, E2's problem in this respect mainly lay in her knowledge of the English language.

In summarizing her impression of the tutor's feedback on her first assignment, E2 said she felt that the comments were too general and superficial, without profound and detailed criticism. What the tutor did point out seemed to her to be trivial mistakes or negligence, such as the referencing, and cross-cultural issues (transb5:5). She was not satisfied about the fact that the tutor only provided an overall comment, without marking or writing anything inside the assignment. In short, E2 did not think this feedback provided her with useful guidance for future assignments.

The discussion in this section seems to suggest that discrepancy may exist not only between what the tutors expected to see in the students' assignments and what the students actually produced; but also between what the students expected to see in the tutors' feedback and what the feedback actually looked like. There were language

---

<sup>13</sup> She usually made an effort in trying to contact the tutors for advice on her assignments. She said that the reason why she did not bother to contact the tutor this time was mainly out of her laziness: she felt that email was not a good way to clarify her questions about the comments, and she did not want to take the trouble of arranging a face to face meeting. She said there was also the issue of accessibility of the tutor (personal communications in August 2005).

barriers that prevented non-native English speaking Chinese students like E2 from fully understanding the tutor's comments, which in turn made the comments less useful. Furthermore, her reluctance in communication with the tutor regarding her difficulty in understanding the comments kept the comprehension problems unsolved, thus undermining the usefulness of the tutor's feedback.

On the whole, the analysis of the process of constructing the 'object' in both E1 and E2's cases demonstrates quite clearly the inter-relatedness of the reading and writing practices in the academic discourse community: e.g. the groups of readings the students did and the ways in which different readings were read and integrated into writing were all determined by the writing task. The analysis also shows that accounting for both central (e.g. reading of academic texts) and 'peripheral' (e.g. reading of tutor comments and task requirements, etc.) academic reading practices were essential in understanding the students' experiences of academic literacy and academic studies in the UK university setting in question. Therefore, it is necessary and sensible to study reading from a contextualized approach that this study is adopting.

## **6.4 An Activity System View of E1 and E2's Cases**

Having discussed the details of E1 and E2's reading practices for writing their first assignment, I will present an AS view of E1 and E2's cases by exploring the 'subject' component of the AS and the relationships between the 'subject' and other components in order to identify possible causes for the subjects' reading experiences. In so doing, I will also draw attention to the similarities and differences between E1 and E2.

### **6.4.1 'Subject'**

The 'subject' is the agent in the AS from whose point of view the AS is constructed. Therefore, it is the first component that will be discussed here. In doing so, I will focus

mainly on two aspects of the 'subject'—i.e. the subject's personal history of literacy and education, and the emotional dimension of the subject's literacy practices, in line with the way that the NLS framework gives particular emphasis to the effects of these two aspects on the 'subject's' current literacy practices.

#### **6.4.1.1 Personal Literacy and Education History**

As two students with different educational background and life experiences, it would not be surprising to find E1 and E2 dealing with the same reading and writing tasks differently. First of all, the analysis above indicates that their self-perception or self-image influences their reading practices. For example, E2 always perceived herself as an average student, which appears to have made her tend to follow the tutors' instructions more closely concerning reading tasks, regardless of her personal interest, personal relevance, or the task difficulty<sup>14</sup>. E1, on the other hand, being a top student throughout the years of her education, tended to follow her own preference of reading rather than the tutors' requirements (e.g. she gave up reading what she found incomprehensible, uninteresting, or very likely irrelevant to her future career - see 5.3.1 above).

While the influence on E1 and E2's reading practices of their self-perception/image had more to do with life-long experiences, the following difference, regarding their choice of topic for their first assignment, appears to have had more to do with their experience at university in China. E2 had experience of doing research in education during her undergraduate years as a student of history education. She borrowed the topic of her previous research which was designed by her tutor at that time for this assignment, so that she saved time and effort in developing a topic of her own (also see

---

<sup>14</sup> During the first term, E2 reported (transb1:7-8, transb2:13) that she almost always did pre-reading tasks, no matter how difficult, or boring a reading might be. She didn't give up pre-reading even while she was writing her assignment (see 5.3.2.2 above).

6.3.1.1 above). E1 had no experience of doing any research in any area before, which forced her to start thinking about this assignment early. Taking into account her own interest, E1 decided on an initial focus which was subsequently further developed and refined through wide reading in the subject area (see 6.2.1.3 above). E1's effort in this respect was positively acknowledged by her marker's comment<sup>15</sup>. Whereas in E2's process of constructing the 'object', she did not go through the stage of reading in order to choose a subject area for the research proposal as she decided to use the topic designed by the tutor of her undergraduate studies in China. It is likely that the relatively smaller amount of prior thinking in deciding on the topic may have also affected her mark.

There were some other differences in the specific process of constructing the 'object' between E1 and E2. For example, E1 did not start writing until she finished most of her reading and she wrote from the first section of the assignment to the last, one by one; whereas E2 first focused on readings concerning the design of the research and questionnaire and the writing of the corresponding sections, and then she turned to tackle the section on the theoretical framework, which she considered most difficult and saved to the last, doing more searching and reading of the relevant literature.

On the whole, E1 and E2's self-perceptions as students and as persons which were established during the years of their education in China, and their education and working experiences jointly affected their academic reading practices in the Lancaster AS of the MA in Education programme, though the general stages they went through in the course of reading for writing and their ultimate overall 'object' of their reading, i.e. trying to produce a satisfactory piece of writing on the basis of the knowledge and ideas

---

<sup>15</sup> The marker commented that "the proposal begins with a useful review of the literature on stress of both home and international students and argues that this area has not been the subject of a specifically focused inquiry before. ... This is a good discussion of the focus for the study" (appendix 9).

gained from reading, were similar.

#### **6.4.1.2 Emotional Aspect—Seeking a Sense of Security and Certainty**

Take E1 as an example first. Her activity of reading for writing her first assignment started from the beginning of the first term, and lasted for almost six weeks. Judging by the analysis in the foregoing parts (see section 6.2.1 above), the reasons for this appear to have mainly lain in E1's sense of insecurity and uncertainty in the new learning environment: firstly, E1 was unfamiliar with the UK higher education system, so she was not sure how much effort she should put into writing assignments. Secondly, the particular assignment discussed in this chapter was the first assessed work that she needed to turn in, and she did not have much previous experience of academic writing to draw upon, as she said: "this was the first time (for me to write a research proposal). I had absolutely no idea how to do research (transa2:19, my interpolation)". Thirdly, this assignment was a research proposal, which required knowledge of doing research in general and knowledge of a specific topic for her proposed research, both of which was absent on her part. The only safe way out was to take the assignment seriously and started working on it early.

Right at the beginning of the first term, as soon as she discovered that the recommended textbook was difficult to read as it was "full of abstract terms and concepts (transa2:16)", she immediately tried to look for and managed to find some easier books on research, which helped a great deal with her understanding of the structure of the research proposal. From as early as week two, she started thinking about the topic of the research proposal and started searching relevant literature by various means and reading extensively in order to narrow the topic down (transa1:28). Around week four or so, the course convener circulated a more detailed assignment guideline (appendix 8) in response to various questions that students asked about the

assignment, which E1 studied very carefully. In one of the interviews, she once remarked that it was the two books on research design and the tutor's assignment guideline that made her feel sure how she should do this assignment (transa2:19). She also studied closely a version of this assignment done by a former student, which was distributed to all current students at the beginning of the term. This sample served as a model for her writing, which she referred back from time to time to ensure that her own writing did not go wrong. By the time she finished writing, she was quite certain that she had followed the writing requirements closely (transa3:1).

E2's experience in this respect while doing her first assignment was quite similar to E1's, except that E2 also frequently consulted the tutor for advice. The tutor's prompt and useful replies saved her much time in searching the right literature.

In short, an early start and extensive reading of the right literature were two essential factors that provided E1 and E2 with a sense of security and certainty, which in turn ensured the successful fulfilment of this assignment. E1 and E2's desire for seeking a sense of certainty and security, seemed to guide their reading practices during the process of writing the assignment for the IER module (e.g. urging them to make the right decisions for what readings to do carefully and what to do briefly, how to use each reading differently, etc.); and such positive emotions, in turn, seemed to facilitate their accomplishment of this assignment. E1's experience of doing other assignments also confirmed that lack of good time management and lack of the right type of literature, which prevented the formation of the positive emotions (e.g. a sense of security and certainty) may lead to disaster (this will be discussed in 7.3.1 below). E2's active communications with the tutor also proved very effective and helpful in providing the sense of security and certainty while she wrote the assignment for the IER module. However, when she could not get this kind of helpful support from her tutors, the



process of seeking a sense of security and certainty was disturbed, which also negatively influenced her experiences of academic reading and writing. In a sense, E1 and E2's desire for seeking a sense of security and certainty functioned to guide the decisions they needed to make in their academic reading activities. Equally, as will be shown in 7.3 below, the disturbances and obstacles that prevented these subjects from achieving positive ruling emotions in a subsequent assignment can be seen as having led to undesirable academic reading experiences on that occasion.

### **6.4.2 Relationship between the 'Subject' and 'Community'**

The relationship between the 'subject'—the two Chinese students in question, and the 'community'—staff and other students in the same MA programme is examined first among all the relationships between the components because it concerns the relationships between people, and also because the relationships between the 'subject' and 'rule' and 'division of labour' were often embodied in the interactions between the 'subject' and 'community'. I will examine the relationship between the 'subject' and 'community' from two perspectives: cooperative and supportive relationship, i.e. the 'network of support' on the one hand, and conflicts on the other.

#### **6.4.2.1 Network of Support**

'Network of support' refers to people to whom E1 and E2 turned for help or who offered help without being asked for. In E1's case, she once sought support from her tutor by asking questions via email; she consulted me as a researcher and friend for advice on choosing a topic; she learned from some friends about on-line journal databases that she used quite extensively. Although it seems that her network did not spread widely, with a written sample of this assignment and a very detailed guideline from her tutor (see appendix 8), E1 still did a good job. For E2, in doing this assignment,

the primary source of support, concerning reading and writing, was the tutor, to whom she wrote emails asking various questions for her research and from whom she got very clear and helpful answers. A particularly difficult question she asked was about the possible theoretical framework for her research and she realized later how crucial the guidance from this tutor was in this respect, since many of her course mates still had no idea of their theoretical frameworks even when they submitted the assignment (transb2:8). Her marker also recognized this as a strength of the assignment, saying that “you’ve done a useful range of reading, and have hit on professional identity as an appropriate organising concept” (appendix 10).

#### ***6.4.2.2 Conflicts between the ‘Subject’ and ‘Community’***

Due to the inner conflicts between the ‘subject’ and ‘community’, and between the ‘subject’ and ‘rule’ (see 5.5.3 and 5.5.4 above), discrepancies exist between the tutors’ and students’ understanding of the purposes and functions of reading in relation to teaching sessions, of the expectations of written work and feedback, and of the language used in assignments or feedback. For example, for term-time reading, both E1 and E2 only aimed to understand the readings, whereas some of the tutors hoped they could be stimulated by the readings and generate their own thoughts and arguments (see 5.5.3 above). In some seminars based on certain readings, tutors found that students did not read in a way that enabled them to participate effectively in the discussions (transst1:5-6, transst3:5). Besides, some of the later assignments required students to produce critical reviews of academic papers, which could not be satisfactorily fulfilled if students only aimed to understand rather than critically evaluate the readings (there will be a discussion concerning this topic in Chapter 7 (7.3.2.3.1 below)). Sections 6.2.2 and 6.3.2 above have both presented examples of lack of understanding or incomplete understanding between the students and tutors. For instance, tutors criticised E1 and E2

for not mentioning certain issues that should have been included, when E1 and E2 had in fact either considered the issues but not stated them explicitly in the assignments (because they thought it unnecessary to mention such issues (transa3:3, transb5:2)), or had mentioned them in certain ways that the tutors still felt insufficient (transb5:3).

There were also occasions when students could not fully understand or even misunderstood tutors' comments probably due to a language problem. One occasion was when E1, while justifying her choice of using a questionnaire rather than interview, E1 wrote "interview ... is highly subjective and therefore there is always the danger of bias". The tutor commented,

Subjectivity is more or less always present in research instrument if you mean 'bias'. In questionnaires it is present in the order of questions, the choice of questions, the weighting of variables etc.' (appendix 9).

While the tutor appeared to wish to point out that questionnaires cannot be completely objective, the message that E1 got from this comment was that the tone of her statement was too subjective and that she should use less adverbs such as 'highly', 'overwhelmingly', 'obviously', and the like (transa3:1). Therefore, we can see there may be gaps between what the tutor intended to convey in and what the student took from the comments.

Whether they were aware of the difficulty in understanding tutors or not, the students may not try to contact tutors for clarification mostly due to their laziness. Considering the 'rule' and 'division of labour' in the Lancaster AS (see sections 5.4.5 and 5.4.6 above), which involves student initiative and playing an active role in study, the norm would be for the students to be proactive in seeking more communication with the members of staff so as to lessen misunderstanding between the two parties. Meanwhile, the responsiveness on the part of the staff may also be crucial to encourage students' attempt of communication with them. The module IER convener's prompt responses to individual students' queries, and the way these also resulted in a more

detailed set of assignment guidelines being provided for all the students, were examples of good practice in this respect. Without the supportive response from this convener, students may have found more difficulty in the course of doing this assignment. More discussion of this issue will appear in Chapter 9 (9.4.3.1).

## 6.5 Conclusion

This chapter has presented a detailed picture of E1 and E2's reading practices while writing their first assignment. The overall findings and conclusions are as follows: Firstly, despite the differences between the current AS and their past AS (see Chapters 4 and 5 above), E1 and E2 made a successful adjustment to the new contexts in certain aspects (such as use of the library, Internet resources, etc.) and fulfilled the first assignment with satisfactory results. However, there were also certain aspects where their adjustment was not so good (such as understanding of the function of lectures, understanding of tutors' expectations about students taking the initiative and main responsibility in learning, and so on). Some of the negative consequences of these factors, as they affected the students' subsequent performances, will be discussed in Chapter 7.

Secondly, it seems that the relationship between the 'subject' and the 'community' (members of staff in particular) influenced, to a great extent, the students' learning experience and performance. The more supportive the 'community' is, the more rewarding the students' learning experiences and hence the better performance they may possibly achieve. E1 and E2's experiences of doing the first assignment were a case in point: without the module convener's prompt responses to their email, without the sample writing, or without the further assignment guidelines, it seems likely that they would not have done as good a job, nor would they have had as smooth a set of experiences during the course of their reading and writing. Full communication

between the two parties is the crucial element that makes the supportive 'community' possible. If E1 and E2 had not asked the convener for advice, they would not have got help from the convener; if there had not been many students asking similar questions about the assignment, the convener would not have thought about producing further guidelines. Moreover, if the tutors could have been more explicit about the use of pre-readings and the purpose of choosing particular readings, the students might have benefited more from reading and might have read in a way that the tutors would have liked them to; and if they had asked the markers of their first assignments about the comments which confused them, the students could have benefited more from this writing experience. It can therefore be argued that the students need to take more initiative in seeking opportunities to communicate with tutors, and meanwhile tutors need to be responsive in order to make the communication possible. Lack of effort on either part will make communication impossible (there will be further discussion in Chapter 7 concerning this point).

This chapter has examined the reading experiences of E1 and E2 in connection with their first assignment from a perspective of academic literacy practices that was described in Chapter 2, i.e. a combined NLS/AT approach. By the use of this framework, it has been possible to see how the subjects' academic reading practices have been shaped by their past education and literacy experiences, their established attitudes towards reading and learning, the relationships between the components of the Lancaster AS, and the differences between the Chinese and Lancaster AS.

In this way, it has been possible to see that far from being simply a matter of 'technical skills', academic reading practices also involve the interactions between various elements in the personal, historical, cultural, institutional and social contexts. The combined framework of NLS and AT approach seems able to help me gain more

insights into the Chinese students' academic reading practices at Lancaster University and the ways in which their experiences of academic reading may be more rewarding and their learning experiences more beneficial than adopting an 'autonomous' view of reading.

In Chapter 7 that follows, I will discuss E1 and E2's experiences of doing the assignment for the TLA module, using a structure similar to the one I have followed in the current chapter, in order to see how and why their experiences of reading for writing another assignment may be similar or different to the one discussed in the current chapter.

Chapter Seven: Doing the Second Assignment—E1 and E2's Experiences.....	238
7.1 Introduction .....	238
7.2 The Process of Construction of 'Object' .....	239
7.2.1 Choosing the Topic.....	239
7.2.2 Understanding the Task and Identifying Readings .....	241
7.2.3 Searching for the Readings .....	243
7.2.4 Reading and Integrating Reading into Writing.....	245
7.2.4.1 E1's Case .....	245
7.2.4.2 E2's Case .....	248
7.2.5 Summary .....	250
7.3 A System View of the Academic Reading Practices for Writing .....	251
7.3.1 'Subject' .....	251
7.3.1.1 The Influence of Personal History .....	251
7.3.1.2 The Emotional Aspect of Reading for Writing .....	253
7.3.2 'Subject' vs. 'Community', 'Rule' and 'Division of Labour' .....	257
7.3.2.1 Network of Support .....	257
7.3.2.2 'Subject' and 'Community'—Non-cooperative Relation .....	258
7.3.2.3 'Subject' and 'Community'—Mismatch of Expectations .....	259
7.3.2.3.1 Regarding the Critical Review .....	259
7.3.2.3.2 Tutor's Feedback on the TLA Assignment vs. Students' Reflection.....	262
7.3.2.4 'Subject' vs. 'Rule' .....	265
7.3.2.5 'Subject' vs. 'Division of Labour' .....	266
7.4 Conclusion.....	268

## Chapter Seven: Doing the Second Assignment—E1 and E2's Experiences

### 7.1 Introduction

In this chapter, I will focus on E1 and E2's reading practices while they were writing their assignments for the MA in Education 'Teaching, Learning and Assessment (TLA)' module. The assignment for the TLA module consisted of two tasks: Task A was a review task of 1000 words and worth 25% of the total mark, and Task B was related to Task A but was longer (3000 words) and worth 75% of the total mark (appendix 12). There were two topics with two different papers for critiquing<sup>1</sup> for Task A, and separate requirements for Task B (appendix 12). E1 chose the second of the Task A topics and E2 chose the first. Their reasons for choosing their topics varied and so did their experiences of reading for the assignment. The marks they received for this assignment were as follows:

---

<sup>1</sup> These papers were often referred to as 'target papers' in the data, thus I will also use the term 'target paper' from this point onwards.

- E1 - 61 (57 for Task A and 62 for Task B)
- E2 - 56 (for both tasks).

By discussing E1 and E2's experiences in doing the TLA module assignment, I will show how their reading practices were both similar to and different from those of their previous assignments. Also, unlike Chapter 6, which looked closely at the process of reading *per se* in relation to the students' assignment for the 'Introduction to Educational Research' (IER) module, the discussion here provides a more system-oriented view of the matter by in-depth discussion of the components of the AS and the relationships between these components. It concludes with an overall discussion of the AS of the MA in Education programme and the subjects' academic reading practices that took place within this system.

## 7.2 The Process of Construction of 'Object'

Similar to E1 and E2's IER module first assignment writing process, there are the following stages in the whole process of constructing the 'object' in their reading activities for their TLA assignments as well: choosing the topic, understanding the task and identifying readings, searching readings, reading, and finally integrating reading into writing (see figure 7.1 below). However, although the general process remained similar, E1's process of doing this assignment was full of dramatic ups and downs, as will be revealed during the discussion that follows; whereas E2's process was relatively smooth.

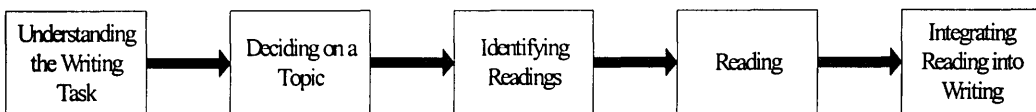

Figure 7.1: Constructing the 'object'

### 7.2.1 Choosing the Topic

There were two topics for the students to choose for this assignment: one was



concerning the contents of the first seven course sessions, i.e., Vygotskian theories, such as scaffolding and ZPD; the other concerning the contents of the last three sessions, i.e., motivation. E1 chose the second topic simply because it only involved three sessions, which she felt probably meant less work for her<sup>2</sup> (transa4:17, transa5:1). However, it turned out that she thought too positively about the seeming advantages of choosing this topic while overlooking the hidden disadvantages, as she realized later: firstly, as was her usual practice, she did not do pre-reading tasks for those sessions, which meant she did not get any input from those readings; secondly, she said she did not get anything from the teaching sessions because the lecturer gave what she thought boring lectures and she found the contents difficult to understand, which made her finally lose interest in listening to the lectures<sup>3</sup>; thirdly, she felt the lecture handouts were too concise to provide her with an overview of the main theories in this area; finally, there were so many course mates writing about this topic and hence competing for limited resources that she could not get hold of any of the necessary books when she started working on the assignment one week before the deadline, which was disastrous for her in particular, since, because of her previous inaction, she now needed to learn everything about this topic by herself from such sources (transa4:17, 30, transa5:1).

In contrast, E2 made a sensible decision to avoid the second topic because she “could not understand a single word in the ‘motivation’ sessions (transb6:10)”, nor could she understand the pre-readings, which were full of statistics and models (transb6:10). The process of choosing the topic described above seems to show again that not only the reading of academic texts particularly for the purpose of writing assignments but also reading of lecture notes, pre-readings and the like during the term time played essential roles in the process of reading for writing the assignments (also

---

<sup>2</sup> She might not be the only one making this assumption: 14 out of 16 students in her programme chose this topic.

<sup>3</sup> All four students that I interviewed in this programme had similar complaints about this lecturer.

see 6.2.2 and 6.3.2 for a discussion of the role of more 'peripheral' types of academic reading practices).

In addition to the choice between the two topics, there were two tasks for both topics: Task A being a 1000-word critical review of a target paper, and Task B a 3000-word essay related to the issues in the target paper (appendix 12). By choosing the second topic, E1 had to make another decision for the focus of Task B, as was stated in the requirements that "there are too many theoretical approaches to motivation for it to be possible to sensibly cover them all here, so you will also need to select your theoretical point of focus, and to argue for your choice" (appendix 12). E1's choice of 'rewards' as her focus was inspired by a course mate who also wrote about 'rewards', and E1 happened to find relevant references in this area, which enabled her to accomplish the task (transa5:3). Her marker had positive feedback on her choice of the focus, saying that "the choice of rewards systems as a focus for the essay is a good and appropriate one" (appendix 13). E2 did not need to make any decision in this respect since the requirements of her topic had already listed very specific questions (appendix 12 for assignment details); and by simply answering these questions one by one, E2 could be able to produce the writing.

### **7.2.2 Understanding the Task and Identifying Readings**

Both E1 and E2 experienced difficulty in understanding the requirements of Task A—a critical review of a target paper (appendix 12). E1 had thought she just needed to provide a summary of the target paper. But since she was not sure about her understanding of the right way of writing critical reviews, she discussed her concern with some course mates and myself. One of her course mates had consulted the tutor about this issue and got a response from the tutor which went "you shouldn't say I like this part. You should say why you like this part, why they are good", which made her

realize that she had to argue for or against some of the arguments of the target paper as well as provide a summary (transa4:12). Before she started doing this assignment, she got the tutor's feedback on another critical review task, which further clarified to her that she should not only form her arguments about the target paper but also find evidence in the literature to support her arguments, and that she should try to criticize the article as well as complement it (transa4:7). However, she still did not have a clear idea about what to read except the target paper for Task A because it was in itself a very comprehensive review article with 16 pages of references. As E1 put it, "the target paper has made use of almost everything on 'interest' and 'goal', some of which I even don't have access to. What else can I find (in addition to the huge number of references used in the target paper) to support my arguments?" (transa4:26, my interpolation). Therefore, although E1 successfully identified the area of readings she needed to do for Task A, she still had difficulty in doing the task.

E2, fully aware of the importance and benefits of communicating with the tutors, again emailed the tutor to ask for clarification of the requirements for Task A (transb7:6-7). The tutor explained clearly that E2 should compare how the author of the target paper writes about the neo-Vygotskian theories and how other authors, such as those of the pre-readings, write about the same topic (transb7:6-7, transb8:4). Also from the tutor's reply, E2 inferred that the pre-readings were suitable ones to use for writing Task A.

Both subjects found Task B of their respective topics easier to understand. E2 did not ask her tutor for further clarification, as the requirements were very clear to her, i.e. she should provide a literature review about the neo-Vygotskian theories, which was an extension of what she did in Task A, talk about the barriers of putting the theories into practice, and then provide possible solutions (transb8:4, appendix 12). As she clearly

understood the writing requirements, she also realized what she should look for from the readings, i.e. neo-Vygotskian theories, barriers in application, and solutions (transb8:4, transb7:8). E1, having decided on 'rewards' as the focus for Task B before she started working on this assignment<sup>4</sup>, had no difficulty in identifying the reading task according to the writing requirements (appendix 12)—she should read on theories of rewards, and research studies on rewards which could inform her how to better motivate students in classroom (transa4:19). At this stage, reading mainly involved more 'peripheral' type of academic reading such as reading of the writing requirements, of tutor emails, and so on.

### 7.2.3 Searching for the Readings

While doing this assignment, both E1 and E2 reported that the reading lists provided in the handout played an important role in helping them search for relevant literature—the majority of their references were from those reading lists (transab6:1-2, transa4:2,4). In E2's case, with the help of the tutor, she already considered pre-readings as key readings, especially for Task A (transb7:6-7). However, she found pre-readings alone could not provide her with sufficient ideas for Task B, so she had to search for other references as well (transb6:5). Before she used the key word search in the library catalogue, she tried to look at the references in the additional reading lists provided by the module tutors and found them useful, which saved her time searching for her own references (transb6:1-2). Although she could not find everything in the reading lists that she would like to read, E2 could still get hold of two thirds of them in the library (as there were only two students in her programme doing this topic) which were enough for her to do the assignment (transb6:5).

---

<sup>4</sup> E1 started working on this assignment much later than her course mates, some of whom had almost finished writing before E1 had even started thinking it over seriously, so that she got inspiration for the choice of focus from a course mate when a group of them were exchanging experiences of doing this assignment (transa5:3).

Similar to E2, E1 used the reading lists provided by the tutors as the main source of reference—all the books she used came from those lists, with a couple of journal articles searched by herself in the library e-database. Apart from that, however, E1's experience was quite a different story from E2's. Since she started working on the assignment much later than her course mates, E1 went to the library only to find that every single book on the topic of 'motivation' out on loan (transa4:17). She started panicking from that moment because she knew that without appropriate reference books, she could not possibly write the assignment, especially when she had learned nothing about the topic from the teaching sessions (transa4:18-19). Fortunately, two of her course mates were willing to share some books with her. From those books she happened to find readings relevant to her chosen area of focus—'rewards' for Task B. She was also lucky to find relevant journal articles from the e-database (transa4:19, transa5:2, 4). She also discovered some tips for quickly finding useful references: e.g. exchanging ideas with course mates was a shortcut to learn about the usefulness of references; in the library catalogue, the more reservations a book has, the more useful it is (transa5:4). Due to her problem of getting hold of reference books and also being a bit unwell, she applied for and was granted two weeks' extension, which gave her some time to recall more books (transa5:3). Despite that, the overall number of references she was able to include in this assignment were fewer than in some of her other assignments because of lack of availability of the books, and of e-journal articles on the topic of 'rewards' (transa5:6). Although in the end, she was able to get the minimum necessary number of references for Task B, she was still at a loss what references to use for Task A since the authors of the target paper almost exhausted all the references in the area of 'interest' and 'goal' (transa4:26, also see 6.2.2 above). Only after she finished Task B did she manage to find a couple of references from a book she read for Task B to support

her arguments in Task A (transa5:7).

## **7.2.4 Reading and Integrating Reading into Writing**

As was the case while writing their first assignment, readings were read differently by E1 and E2 depending on their intended uses in the writings. Here I will talk about E1 and E2's cases in turn to reveal their practices and the similarities and differences between them.

### **7.2.4.1 E1's Case**

In interviews with her at this stage, E1 described herself as a “totally extrinsically motivated student” in terms of motivation theory, and one who “totally avoids performance goals” in terms of goal theory (transa4:20). Therefore, she only read what was directly useful for her writing (transa4:21). The first item she read and the only one that she made notes on was the target paper, since it was the starting point and the basis of the whole assignment (transa5:1). She read the whole paper carefully twice, because she needed to write a summary of the main arguments in it and also to critique them. The first time she read it, she attended more to the details (such as the meaning of words and sentences) of it, consulting the dictionary for new words while she went along. For the second time, she paid more attention to the general ideas of the article, underlining important sentences, and summarizing main ideas of paragraphs in the margin of the pages (transa4:18, transa5:1). While she was writing Task A, she read the target paper a third time. Thanks to the notes she had made, she could quickly turn to the parts that were relevant to her writing and read them only, instead of going through the whole paper again (transa5:7). In fact, she did not start writing Task A until she had finished Task B, because firstly, she had a bad experience of writing a critical review for another module, which made her feel afraid of similar tasks; secondly, Task B was relatively

independent of Task A and could be written without relying on the fulfilment of Task A; and thirdly, Task B accounted for 75% of the whole assignment, the completion of which would greatly ease her anxiety and pressure from this assignment (transa5:1,2, transa4:22). Therefore, she went straight on with readings for Task B after she had read the target paper twice for Task A (transa5:1, 2).

Apart from the decisive role of the target paper in Task A (i.e. being the basis of the summary and critiquing, transa4:22, 24), another important function of reading the target paper was to clarify her approach to Task B, and hence to determine the reading list for it. She decided, after reading the target paper, that she would argue for the positive effects of 'rewards', and therefore, she would particularly look for arguments to support this aspect (transa5:5-7). As was discussed in 7.2.2 above, E1 had already identified two purposes of reading—one was to find out the theories about 'rewards', the other to find out ways of applying the theories to classroom practice from the existing research studies. There were two books and three journal articles which played a key role for her in Task B (transa4:19, transa5:3). For one of the books, she carefully read the first six chapters twice—line by line, page by page, chapter by chapter, without skipping anything (transa4:20, transa5:4). She did not usually make notes except when she read the target paper. Instead, she underlined important parts and folded the corners of the pages with key points for easy relocation (transa5:5). This book not only provided her with a systematic overview of the relevant theories, but also offered many cases to help her understand the theories and generate ideas of application (transa4:19, 21, transa5:2, 3). After reading this book, she formed a rough outline of the essay for Task B (transa5:5). The key journal articles were read and marked in a similar way (transa5:5). She felt that journal articles were usually more compactly structured, thus easier to make use of in writings: for example, she could find theories, comprehensive reviews of

existing research studies, and case studies in those articles that she could use in her writing (transa4:19, transa5:5). She read three key articles in a way similar to the reading of the key book. Besides the key readings, she read other references more briefly by only looking at certain sections that she thought relevant (transa5:4). The more she read, the clearer she was about the structure of the essay and what to put in each section. After finishing about a dozen readings, she was ready to write Task B. As for Task A, she read sections in a couple of books and journals to find evidence for supporting her argument (transa4:23).

From the above discussion, it is not difficult to see the differentiated treatment of readings by E1 according to their potential uses in the writing. Generally speaking, E1's reading served two major purposes in the process of writing. First of all, it helped her think. For example, readings on theories helped her organize her thoughts and structure the essay (transa4:20, 21, transa5:5); reading of the target paper set the tone of her main arguments in Task B and gave a direction for her further reading for Task B (transa5:5-7); reading of case studies helped her generate ideas and organize arguments for the second half of the essay, i.e. 'how to minimize the harmful effects of rewards' (transa4:20). Secondly, it provided her with evidence from the literature to support her arguments (transa4:20-21, transa5:5), without which her essay would be considered unacceptable as academic writing.

Accordingly, she used four ways of integrating readings into writing. Firstly, the target paper was the basis on which the summary and critiquing in Task A were made (transa4:22, 24-26). Some readings (the target paper included) were transformed into the structure or organizing thoughts of the essay and might not appear overtly as sources of reference (transa4:19-21, transa5:5). Some readings were quoted either to introduce the theories or to support her arguments (transa4:19-21, transa5:5). Quotations were



preferred to citations because she was afraid of misinterpreting those abstract sentences (transa4:20). Still other readings provided cases to illustrate her arguments for the application of the theories (transa4:20, transa5:3, 6). Except for the roles of the target paper, the ways in which readings were integrated into writing were similar to those for the IER module assignment (cf. 6.2.1.5).

#### **7.2.4.2 E2's Case**

Unlike E1, who did not know for sure what to read in order to write Task A, E2 already had a clear idea of the readings for Task A thanks to her communication with a tutor about this assignment. Therefore, she started with Task A. Like E1, the first item E2 read and the one that she read most carefully was the target paper (transb7:6). By reading carefully, she meant reading word by word, sentence by sentence, without skipping anything (transb6:5, transb8:2). She read it at least three to four times, each time making different notes or marking the text in different ways. For example, the first time she read through it, she was looking at the general structure of the paper, marking at some points and making notes in the margin. The second time she read it, she made notes in a separate paper in order to have a clearer view of the main ideas. The third time, she paid more attention to the deeper implications of the paper and see what and how she should comment on the target paper according to the writing requirements. The reason why she read it again and again was because she knew even though she might have understood all the details of the paper and its general ideas, she still needed to explore the underlying implications of it and to find a way to critique it (transb7:6). The notes for the target paper were also the most detailed ones that she did for all her readings for the TLA assignment (transb8:1).

According to her tutor, to write a critical review, she should read something similar to the pre-reading items for the teaching sessions (see 7.2.2 above). The next set of

items she read were three pre-readings, which she read two to three times in a similar way to how she read the target paper (transb6:5, transb7:9, transb8:1). Though she had read them and made notes about them before, she still needed to read them carefully again this time because on the one hand, she might have forgotten about some aspects of them, and on the other, she was reading with a different purpose now from the time she first read them (transb8:1). She was used to marking the text or making notes every time she read an item because otherwise she would easily lose track of what she was reading (transb8:1). Every time she read, she found different aspects to mark or to note down, and gained some new understanding (transb8:1).

The notes she made included a brief summary of the main ideas—sometimes a word or two in the margin, such as ‘definition’, ‘characteristics’, ‘why scaffolding’, etc. (transb8:1), quotations that she could put in her writing (transb6:5, transb8:1), a tentative plan of the essay structure, and sudden thoughts and ideas occurring to her during reading (transb7:9).

As E2 reported, the process of reading was also a process of thinking (transb7:9), which was similar to E1's case. For example, when she read about ‘computer-based teaching activity’, she was thinking about its possible differences from ordinary or conventional teaching, and judging whether the arguments about computer-based teaching were sound and convincing (transb7:10). If she agreed with the arguments, she then would try to find other evidence to support her approval of them (ibid). Moreover, when she found evidence that she might be able to use in the writing, she often needed to think about how to modify it to serve her own purpose, since it was often originally used for a different purpose (transb7:10).

Apart from the target paper and pre-readings, she read other readings only once, though she did not usually skip anything within the readings. She noted down what she

thought useful or marked the texts, but not in as much detail as she did for the target paper and pre-readings (transb8:3).

To sum up, in E2's case, readings were handled differently according to their different uses in the writing, and the functions of reading mainly included providing useful quotes, helping her think and generate ideas for different sections, providing examples of how to comment on the theories and practices of scaffolding and ZPD, and providing sources of evidence to support her claims and arguments (transb7:8-10, transb8:3).

### **7.2.5 Summary**

The analysis of E1 and E2's reading practices while doing their second assignment in section 7.2 has demonstrated that there was a general process that E1 and E2 went through while writing both assignments with the following stages: choosing the topic, understanding the task and identifying readings, searching readings, reading, and finally integrating reading into writing (see figure 7.1 above). On the other hand, there also seem to have been both similarities and differences between E1 and E2 and between their first and second assignments. For example, for both subjects and for both assignments, academic reading (both central and 'peripheral' types of academic reading practices) played an essential role in students' academic writing and in their whole experiences of academic studies in the UK academic discourse community. There were differences between E1 and E2 concerning their choice of topic and process of decision making, their way of reading individual items, of note taking, of searching references, of time management, etc. How well the two of them did in each of the stages also varied. In the following part, I will investigate the possible reasons for these similarities and differences by exploring the components in the AS and the relationships between the components.

## **7.3 A System View of the Academic Reading Practices for Writing**

In this part, I will mainly discuss the 'subject' component of the AS, as it is the agent from whose point of view the whole AS is constructed, as well as the relationships between the 'subject' and other components in the AS. The 'object'—another important component in the AS which shapes and directs the activity in question—has already been discussed in section 7.2, when the process of constructing the 'object' of the reading activities for the purpose of writing was explored, and therefore will not be discussed again here.

### **7.3.1 'Subject'**

In this section, I will discuss E1 and E2's personal histories and the emotional aspect of their experiences during the course of reading for writing this assignment, as these two NLS-based concepts - both integrated into the 'subject' component in the AS - seemed to be very influential in the subjects' academic reading experiences in this instance. The two subjects' personal histories and the differences between them will be examined first, in order to explore the causes for the different experiences E1 and E2 had in doing this assignment, and this will be followed by a discussion of their emotions during the course of their reading and writing.

#### ***7.3.1.1 The Influence of Personal History***

E1's problems while doing this assignment were mostly caused by her late start—the task was assigned to the students at the beginning of the first term and was due towards the end of term two, yet she started working on it just one week before the deadline. For instance, her biggest problem—lack of reference books - was mostly due to her late start, which in conjunction with other factors such as her views on the lack of value of the handouts and the unenlightening lectures, her lack of effort and interest in

doing pre-readings, and the fact that many other course mates doing the same topic and competing for the limited resources, left E1 with no sources of input in the relevant area, which in turn made the writing tasks impossible to fulfil successfully. As E1 recalled in an interview after she finished the assignments for the TLA module, whether she could finish the writing tasks successfully was determined, to a great extent, by the availability of reference books, especially those which were not too difficult and abstract yet could provide her with a clear overview of the theories and practices in the area (transa4:17-19). Only after her course mates submitted<sup>5</sup> their assignments did she manage to get more books and to find the task easier to do (transa4:18).

A closer look at her past experiences appears to indicate that her difficult experiences in this assignment were mainly because of a false confidence resulting from the self-image she had developed over the years of her education experiences. Her self-construct of herself as a top student appeared to have given her the confidence to believe that she could finish the assignments in one week. And she had never experienced any failure in the past whenever she tried to fulfil tasks under time pressure. For example, during her undergraduate years, she often prepared for exams when they were very close. While the students were given months to do their undergraduate dissertations, she managed to do it within one week before the deadline. However, she appeared to forget that now she was in a different education system in which the situation may be different (see sections 7.3.2.3.1, 7.3.2.4 below for further discussion). Another of her usual practices as mentioned earlier (see 4.2.4 above) was to only want to invest a calculated amount of effort in her academic study, which led to her choice of the second topic of this assignment, which involved the contents of only three lecture sessions, even though she had not learned anything from the teaching sessions: this

---

<sup>5</sup> She was granted two weeks' extension (see 7.2.3 above for details).

behaviour might be seen, once again, as a product of her over-confidence in her ability of study on her own. It turned out that she did have the ability to work all by herself even under time pressure—in fact, she started out knowing almost nothing in this area but nevertheless managed to finish Task B in about five days, which was not an easy job, though it certainly was painful experience (transa4:18-19, 23).

In contrast, E2, not as confident as E1, chose the first topic even though it involved seven lecture sessions, because she could not understand the lectures or the pre-readings of the second topic (transb6:10). Seeing herself as an average student, she had a more down-to-earth attitude in study. For example, she tried to do most of the pre-readings, tried to listen to the lecturers, and left enough time to do the assignments (two weeks in the case of this assignment, transb6:1), which all made her experience of doing the assignment smoother than E1's. However, apparently also because of her self-image as an average student, she would not try hard to read more or try to integrate more readings into writing (transb6:1, trtransb7:7), so as to get a better result. Towards the end of her process of writing, she felt absolutely fed up with reading and writing and just wanted to get it out of her way (transb6:1).

### ***7.3.1.2 The Emotional Aspect of Reading for Writing***

The emotional aspect of E1 and E2's reading practices has been worth discussing here because it seems to influence, to some extent, the process of constructing the 'object', and hence their experiences of the whole reading and writing activities.

Its effect seemed especially salient in E1's experiences in doing this particular assignment, where she experienced panic, shock, loss of confidence, self-denial, and, finally, regain of confidence. Due to her "blind self-confidence" (transa4:16) as she commented later in an interview, she only left one week to do this assignment, at which point she knew virtually nothing about the topic she was going to write about. She now

realized that her self-confidence at that time was unrealistic because she did not take into account the unexpected situations that might occur to slow down or impede her process of reading and writing. For example, by the time she went to the library to search for the references, not a single book was left on the shelf, which made her start panicking because without relevant reference books to give her knowledge about the topic and the ideas of constructing the writing, she would not possibly be able to fulfil the assignment (transa4:16-17). She was lucky to be able to borrow some books from her course mates and started reading (transa4:19, transa5:2, 4). However, a bigger shock also struck her at that time—she got the result of another essay, which was unexpectedly low. This was the first time in her entire life to get a failing mark, and she was absolutely shocked (transa4:26). Meanwhile, she found the articles that she was reading too difficult to understand. All this pushed her to the edge of break down. She was in total despair and self-denial as she thought about her situation: she had failed her previous essay; she had to apply for an extension to finish the one she was currently engaged with; and she even could not understand what she was reading (transa4:18-19, 21), all of which was against her image of herself as a good student. In fact, she was in such a bad mood that she could not work properly on the assignment. The very idea of doing the assignment made her nervous and she was at a total loss what to start with and felt it almost impossible to finish the task (transa5:1-2, transa4:17-18, 21). Fortunately, she was given a two-week extension, which allowed her to calm down, and made time for her to get hold of more references (transa5:2). With the help of the books that were easier to read, she finally managed to understand more difficult readings and finish Task B fairly quickly – five days to read and write it (transa5:2, transa4:16-17, 19). By the time she finished Task B, she had regained some of her confidence. She did Task B first not only because it accounted for 75% of the overall mark, but also because she was

really afraid of writing Task A—a critical review, which was a similar task to the one that she had failed (transa4:22). Another reason that she felt Task A was difficult was that the target paper had a huge list of references so that she could hardly find any references that were not already used by it (also see 7.2.2 above). Again, the prospect of not being able to find references to help her form arguments and to support her arguments made her feel uncertain and insecure (transa4:25-26). There will be more discussion about her difficulties in writing the critical review in 7.3.2.3.1 below.

Looking back at the whole process of E1's emotional change from confidence, to panic, shock, despair, self-denial, and finally back to confidence (or at least partly confident), it seems that reference books and articles, especially the appropriate ones that were not too difficult to cause confusion and frustration, played an important role in helping her regain confidence and finish the writing task. I am not denying that the soothing effect of the extension also eased a great deal of pressure from her. However, if she had not been able to find the appropriate references to read, it would still have been impossible for her to write the assignment—her experience of doing Task A was a case in point: the difficulty in finding references other than what has been mentioned by the target paper authors made her uncertain again about her ability to write a proper critical review; she finally started writing it because she told herself it only accounted for 25% of the mark and would not matter so much even if she failed again (transa4:22). It was through reading that she gained knowledge and ideas, which in turn gave her the confidence to do the assignment (transa5:7). Besides, time pressure did not seem a big problem for her since she can usually work faster than others (transa4:16, 28). In a sense, reading (reading appropriate references in particular) brought her a sense of security and reassurance. Or in other words, it seemed that she was seeking a sense of security from reading to keep her reassured that she was able to do the assignment. It also



indicated the vital importance of academic reading in the students' academic studies, thus once again confirming that the study of reading should not be constrained to the narrow cognitive approach.

Although E2's experience was not as dramatic as E1's, the emotional aspect also played a role in the process of reading and writing. She spent two weeks on this assignment, which she thought a very long time, and towards the end, she was so fed up with it that she simply wanted to finish it as soon as possible, though she knew there was much room for improvement in her essays and she could have integrated more reading into it to make it more sophisticated (transb6:1, transb7:7). She admitted that she was not in the right mood to study hard at that time (transb8:2). She did not have the enthusiasm to work as hard then as she did in the first term. And that might have been due to the fact that what she learned here was not something practical that she could put straightaway into classroom practice. Although she did not think courses on educational research totally useless, if she could choose again, she would prefer courses focusing more on classroom practices rather than research and theories (transb6:13). Besides uninteresting courses, she also complained about the quiet and boredom of life in a small town, which made her study even more unbearable. Because of such sentiments, it appears that she did not feel like investing all her energy and enthusiasm in her assignment. She treated it as a burden that she would like to get rid of once she was sure it was good enough to pass<sup>6</sup>.

This analysis of the emotional aspect of E1 and E2 with respect to this assignment seems to indicate that emotions may strongly affect literacy experiences in this context, and this possibility should therefore be taken into account by both students and the

---

<sup>6</sup> She estimated at the time of submission that the assignment might get a score between 50 and 60, and it turned out that her estimation was right (transb6:8)—she got 56, which fell into the 'pass' category (i.e. 50-59) according to the Faculty of Arts and Social Sciences marking criteria for master's level assignments (appendix 15).

members of staff. Efforts should be made on both parts of the students and members of staff to prevent the negative emotions from appearing and to facilitate the formation of positive emotions. I will return to the discussion about the tutors' and students' responsibility in the final chapter. Next, I will discuss the relationships between the 'subject' and other components in the AS.

### **7.3.2 'Subject' vs. 'Community', 'Rule' and 'Division of Labour'**

In this part, I will explore the relationship between the 'subject' and its surrounding contexts, which includes the 'community', the 'rule' governing the 'community' as well as the 'division of labour' within it. There are both positive aspects of the relationship which helped to make the 'subject's' experience of reading for writing smoother and easier, and negative aspects that contributed to the difficulties and problems that the 'subject' experienced during the process of reading for writing.

#### **7.3.2.1 Network of Support**

I am using the term 'network of support', which I have derived from the NLS, to refer to the supportive relations between the 'subject' and 'community'. Both E1 and E2 sought help or were offered help without asking for it, which was crucial to their fulfilment of the assignment. In E1's case, she got much useful information through informal discussion with her course mates. For example, she was inspired by a course mate in their casual talk to choose 'rewards' as the focus for Task B, which saved her time in reading around to decide on a topic (transa5:3); by talking to a course mate about critical reviews, she learned that the tutor expected to see in Task A not only a summary but also whether and why she agreed/disagreed with the target paper authors (transa4:12), and this prevented her from making a big mistake; when she could not get hold of any books due to her bad timing, some course mates lent her some of their

references to start with instead of wasting any more of her precious time (transa4:19, transa5:2, 4); when she was absolutely in despair about her assignment and lost all her confidence, she asked me as a researcher and friend to listen to her problems and give her advice. All this support and help may only seem tiny, but without it her experience of doing this assignment would undoubtedly be even worse and the result less desirable.

E2 also benefited a lot from her network of support, and her primary source of support was the members of staff. Ever since her first assignment, she had formed the habit of asking her tutors about anything she was not sure about. More often than not, she got useful replies from the tutors, which gave her direction about what to do and which saved her great effort and much time in finding the way out on her own. For example, her tutor, in a reply to her email, showed her how to use the literature to critically review the target paper; after she finished writing Task A, she emailed another tutor asking about a section in her writing that she thought might have a problem, and again got reply saying that she was not right in commenting on the paper that way, so that she was able to cut that part out (transb8:4). As with E1, without such help and support, E2's experience of doing this assignment would be less smooth and the result might be worse.

### **7.3.2.2 'Subject' and 'Community'—Non-cooperative Relation**

However, in addition to the supportive relationships, there were also non-cooperative relationships between the 'subject' and 'community'. The fellow students in the same MA programme competed for the limited resources such as reference books, tutors' time and attention, etc. That explained exactly why E1 could not get hold of any references when she started doing this assignment. In addition to the competition for resources, according to personal communications with some students from this programme, it seemed that not every student was willing to share useful

information such as experiences passed on by former students, replies from the tutors concerning queries of assignments, and the like, with their course mates, which also reflected one aspect of the non-cooperative relationship among the fellow students.

### ***7.3.2.3 'Subject' and 'Community'—Mismatch of Expectations***

In this section, I will discuss the conflicts between the 'subject' and the members of staff, by looking at the mismatch in their expectations of each other.

#### ***7.3.2.3.1 Regarding the Critical Review***

The first aspect worth mentioning here is the different understanding of the concept of a critical review that existed on the part of the 'subject' (E1 and E2) and the members of staff. As already explained, Task A involved a critical review of a target paper, which both E1 and E2 found difficult to handle, so much so that E1 postponed writing it until she finished Task B (transa4:18, 22), and E2 had to stop writing Task A due to her uncertainty and resumed it after she finished Task B (transb6:10). The original cause of their uncertainty was their receiving unexpectedly bad results<sup>7</sup> for an earlier assignment for another module (hereafter referred to as assignment X for module X) which was also a critical review of a paper. They complained that no tutors from any modules had taught them how to write a critical review before they were asked to do it for the first time (transa4:7, transb6:4, transb7:11). Although they were given fairly detailed guidelines for assignment X, and E2 also asked the module X convener to clarify some of her questions, they still did not meet the tutors' expectation very well, judging by the results they got. However, when they submitted assignment X, both of them were confident that they had done the right thing (transa4:6, transb7:1-4, 11). As they explained, their main problem in assignment X was the way they used literature in

---

<sup>7</sup> E1 got 42 (i.e., a "Fail"), which she reported came as a great shock to her, as she usually viewed herself as a good student. E2 got 53, which, while constituting a low "Pass"-level result, was unsatisfactory to her too.

the critical review. The assignment guideline required them to “*summarise the article and explain how it relates to existing literature on the topic. ... How do his work and his conclusions, compare with any other work on assessment and/or vocational education that you have read...*”, whereas they only used the two theory chapters in a key book for module X as the main reference book to comment on the target paper (transa4:6-7, transb7:2-3). What both E1 and E2 did in their review was to compare the way the author wrote about the procedures of a policy formation with the policy formation theories in the key book, and they both thought quite positively about the target paper in this respect because the author's way of analysing the policy matched the theory (transa4:6, transb7:1). Also, besides their use of literature, they were both criticized for being too descriptive and not critical enough because they mostly agreed with the author's analysis (transa4:6, transb7:1). The module X convener realized that there were some common problems in many students' assignment, so he spent an hour talking about this assignment and listed a group of sentences that were too descriptive in contrast to another group of sentences that were appropriate for a critical review (transb7:2). However, this session did not seem to help E1 and E2 much considering their next experience of doing critical review task.

Thus, despite their first experience of writing a critical review, i.e. assignment X for module X, E1 and E2 still encountered difficulty and uncertainty while they were writing critical reviews for the TLA module assignment under focus. The reason may be not only because the markers' feedback and the brief session on writing a critical review were inadequate to clarify their questions and concerns, but also because the target paper and hence the task requirements were different. Take E1 for example first. From the pervious critical review assignment, she mainly learned two big lessons (transa4:6-7): one was that she had to use the existing literature to comment on the

target paper or to support her arguments about the target paper; the other was that being critical meant one should not give positive comments all the time, but should also find fault with the target paper. She paid special attention to these two aspects while doing the critical review in the TLA module assignment, but only to find that she could do well in neither of them. The reasons she gave for this (transa4:26-27) included firstly, that this paper was not an empirical study, but a review of others' studies and reviews with a reference list of 16 pages. She felt it was difficult to find references in this area that were not mentioned by the authors of the target paper. Secondly, the target paper here seemed to her to cover most aspects of the chosen topic and presented arguments from both sides about many issues. The authors were experts who knew this area far better than E1 did. As a newcomer to this field, it took E1 quite some time to understand and follow the authors' arguments, which she thought well-organized (transa4:25-6). With great effort, she finally managed to give one criticism, which the marker did not think was all that appropriate<sup>8</sup>. E2's experiences echoed E1's in that she also felt that she did not know the theories as well as the authors and that she mostly agreed with the authors' arguments. Although she asked the tutors for advice on the critical review, i.e. TLA module Task A, the marker still thought her review too descriptive (transb8:5, appendix 14).

E1 and E2's experiences of writing critical reviews suggest that both the students and the tutors failed to meet each other's expectations. From the tutors' point of view, they might not have expected to find the students unable to produce proper critical reviews, as they did not appear to make any special effort to help students in writing critical reviews. Or, in other words, the tutors might have assumed that students all know how to write review articles. From the students' point of view, they did not expect

---

<sup>8</sup> While she was writing this criticism, she also knew that her argument was not well grounded. She made this criticism in order to make her review appear critical with some negative comment about this paper (transa4:26).

to get negative feedback on their critical reviews. They wrote the reviews in their own ways since the tutors had not given them special guidance in writing such essays<sup>9</sup>. Therefore, E2 complained that the session on how to do a critical review was taking place too late. She thought that the tutors should have either reminded the students of some common problems from the experience of past students, or given them a session on how to write critical reviews beforehand (transb7:11). She also thought that the 'Study Skills Core Module'<sup>10</sup> was very disappointing because it did not offer them what was most needed, such as how to write a proper critical review (ibid.). Even with the tutors' feedback on assignment X and the session given by the module X convener, E2 still did not think she got adequate information about the proper ways of writing critical reviews, because she needed "concrete examples or sample writings to illustrate what counts as a good critical review, instead of a few bullet points of rules" (transb7:11). E1 held a similar view, also saying that she felt she needed some samples of good critical reviews in order to have a clear idea of what they should do (transa4:27).

#### ***7.3.2.3.2 Tutor's Feedback on the TLA Assignment vs. Students' Reflection***

Both E1 and E2 agreed with some of their markers' comments, and disagreed with others. For example, E1 totally agreed with her marker's comments on Task A about her inappropriate criticism of the target paper, which she already knew when she was writing it (transa4:26, also see 7.3.2.3.1 above). But the problem seemed to be the marker did not tell her how to criticise properly, so she still did not know how to do it next time (transa5:11). What she could not agree with were the comments on Task B about her theoretical framework and the use of theories in her analysis<sup>11</sup> (transa5:9).

---

<sup>9</sup> The reason why some Chinese students find critical reviews difficult to write will be explored in 7.3.2.4 below.

<sup>10</sup> It was a course provided by the MA in Education programme in the first term to help overseas students.

<sup>11</sup> Her marker commented: "I am not so sure that you have provided us with a theoretical framework. You have provided a useful account of the summary findings concerning the claims and counterclaims of the potential effects of different types of rewards upon motivation. However you have not provided very much by the way of attempted

She had been pretty satisfied with her writing of Task B and had not expected such comments (transa5:8). Moreover, she could not see what the marker's point was exactly, so that she did not know how to correct or improve it. In a sense, such comments seemed to her to be a waste of both the marker's and the student's time, since they did not make sense to her, hence could not give guidance for her future work (transa5:9-11).

In E2's case, on the one hand, she acknowledged that some of the comments identified her problems exactly (transb8:5). For example, the marker criticized that the structure of her Task B essay was not reader-friendly since she did not provide any headings or subheadings except 'introduction' and 'conclusion'<sup>12</sup>, that the solutions she provided were too general without exploring any of them in depth, and that the critical review was too descriptive (transb8:5). On the other hand, she was not satisfied with the comments because the marker dwelt on her problem of structuring the essay and gave her a lot suggestions concerning the organization of academic essays which E2 thought a relatively minor problem, while not providing specific and constructive advice on how to improve her critical review or how to explore the solutions more deeply (transb8:5-6). E2 thought it simply beyond her capacity to improve her essays the way the tutor would like her to without substantial help from the tutor (transb8:5). Besides, there were also comments that E2 did not agree with. Firstly, she thought the marker too unwilling to give positive comments, as there was virtually none in the whole feedback (transb8:4). E2 wondered how, if there was no positive aspect in her essay, she could have passed (ibid). E2 also disagreed with the marker's criticism in Task A about her not exploring certain issues because as she understood it, they should not be the concerns of

---

theoretical explanations for these different effects (appendix 13)".

<sup>12</sup> The reason why she did not use (sub)headings in her essay was that she thought they would make the essay look segmented, and that she assumed that the tutor would easily recognize the structure of her essay without them (transb6:6-7). I would also argue that E2 was influenced by the style of Chinese essays in which there are usually no headings.



Task A and should have been considered in Task B (transb8:5). Moreover, there were places where the marker questioned the sources of reference when E2 thought she had already provided them. (It is unfortunately not possible to know exactly what the marker meant by “sources” here because E2 thought it too troublesome to ask the marker by email and the marker refused to be interviewed by the researcher.)

On the whole, both E1 and E2 did not think the feedback constructive enough in that they did not get concrete and substantial advice from the markers on how to write critical reviews properly, or on how to improve the places the tutors were not satisfied with (transa5:11, transb8:5-6). It is also worth noticing that both E1 and E2 did not pay much attention to tutors' feedback. E1 usually had a look at the mark and went through the comments once, paying more attention to negative comments than positive ones (transa5:5). E2 had had great expectations for tutors' feedback at the very beginning, but was so disappointed by the feedback of her first assignment, which was very brief and which only commented on what she regarded as trivial matters, that she did not take any feedback seriously thereafter (transb8:8). Also, unlike E1, E2 usually read positive comments more carefully than negative ones (ibid).

To sum up, mismatch of students' and tutors' expectations existed in the following aspects: what the tutors expected to see in the students' essays did not match the students' actual performance (especially in the case of critical reviews); what the students did not consider as problems in their essays turned out to be problems from the tutors' point of view; the necessary information for the assignment that the students expected from the tutors was delayed and insufficient; what the tutors expected the students to know about the writing requirements was absent on the part of the students; what the students expected to get out of the tutors' feedback did not match what the tutors actually offered. Some of the mismatch of expectations between the 'subject' and

'community' seemed to arise from the conflicts between the 'subject' and 'rule' and 'division of labour', which will be discussed in the next two sections.

#### **7.3.2.4 'Subject' vs. 'Rule'**

The first aspect I will discuss here is again about the critical review, which both E1 and E2 found much difficulty in doing. As E1 pointed out, she had never thought of criticizing published journal articles, since she had never been taught or asked to do so before by any of her tutors in China. In other words, she simply could not tolerate the idea of criticizing published works (transa4:6, 25). E2 also reported not having had any experience of writing critical reviews during her undergraduate years, either. While doing critical review tasks, E1 and E2 both found that they tended to agree with most of the arguments of the authors (transa4:25-27, transb6:3, transb7:1, 3). According to E1, she sometimes had difficulty following the authors' arguments, so that it was already quite an accomplishment for her to understand everything the authors intended to convey; whereas criticising the authors when she even could not follow their arguments seemed to ask too much from her (transa4:25-27). She had also presumed that the tutors just expected to see the evidence of her being able to follow the authors' arguments in the critical review, which, as she later realized from her first failure, was totally counter to the tutors' intention (transa4:6-7). Moreover, both E1 and E2 questioned their capacity to challenge the authors of the target papers, who they believed to have more knowledge of the relevant fields than themselves (transa4:25-27, transb8:7). E2 described her criticizing the target paper as being like a primary school pupil, who just started learning to write and barely knew what was good writing, trying to comment on other's writing (transb8:7).

From E1 and E2's account and reflection of their experiences, I would argue that the way they were educated in China over the years—to respect authorities—has made

them feel incapable of and even resistant to criticizing printed words or published articles. They therefore naturally tended to think more positively about the subject of their “criticism” rather than try to find fault with it. Although they did attribute their unsatisfactory performance in critical reviewing to their lack of knowledge about the subject area, I would argue that lack of subject matter knowledge is but one of the causes for their difficulty. It may have more to do with the habitual way of thinking that they have acquired through years of education (cf. e.g., Cortazzi and Jin, 1996; though also see, e.g., Kubota 1999). Therefore, from this perspective, it is not really surprising that E1 and E2 could not do critical reviews well because it was simply not part of their experience in the education system they came from.

#### **7.3.2.5 ‘Subject’ vs. ‘Division of Labour’**

As was discussed in Chapter 5, the MA in Education programme activity system seems to require its Chinese students to be more responsible for their study than they were used to (see 5.4.6, 5.5.4 above), and during the course of doing assignments, this was even more the case. E2 reported that she benefited a lot from communicating actively with the tutors about her questions on the assignments. For example, for the first assignment, the tutor pointed out a possible theoretical framework for her research proposal, which saved her much time and effort in figuring it out by herself; while doing the assignment this chapter is concerned with, the tutor whom she emailed told her possible ways of commenting on the target paper; and another tutor answered her email by pointing out what she did wrong in her writing so that she could correct it before turning her essays in. E2's experiences seemed to show the advantages of active student-tutor communication. At the postgraduate level, it can therefore be argued, students, Chinese students in particular who were likely less familiar with the UK higher education system, need to take up more responsibility in initiating student-tutor

communication in order to better benefit from their learning experiences.

However, even though E2 sought help from the tutors by initiating various communications with them, she still found it difficult to write critical reviews, and E1, without extra help from the tutors, experienced greater difficulty. The analysis in this chapter indicates that there were occasions when informal communications with tutors might not provide students with sufficient and effective help, especially when the problem is shared by many of them. There may be other occasions where students relied heavily on tutors' taking more responsibility (e.g. lecture handouts, assignment feedback). For instance, some tutors did not provide handouts for teaching sessions, which substantially increased the difficulty for the students to follow the lectures (transa4:1-3). Another aspect in which the students relied heavily on the tutors' taking more responsibility was the feedback on assignments. Both E1 and E2 complained about the simplistic and short feedback for not giving sufficient and constructive information for their future benefit. Handwritten notes within the essay were also reported to be useless since they were simply unintelligible (transa3:4, transb8:1). They both mentioned a tutor who typed out annotated notes neatly on the feedback sheet to be the good example that other tutors could follow (transa3:4, transb8:1). Therefore, it can also be argued that the tutors should take the responsibility for arranging other methods of helping students, such as giving formal teaching sessions, providing sample essays, giving more detailed assignment guidelines, arranging tutorials, and so on.

In short, the experiences reviewed here can be seen as indicating that tutors and students need to take proper responsibility in equal measure for the effective managing of their learning. The implications of this aspect of the data will be discussed further in Chapter 9 (9.4.3 below).

## 7.4 Conclusion

The above analysis of E1 and E2's reading practices for writing the TLA module assignment suggests that the general process of reading (i.e. from choice of topic, understanding the task, identifying reading, doing the actual reading, to integrating reading into writing), the way they searched and approached reading, and the ways in which reading was integrated into writing (e.g. providing them with knowledge of the chosen area, helping them think and structure the essay, giving them support evidence for their arguments, etc.) remained fundamentally similar to the picture presented by the analysis in Chapter 6. At the same time, there were naturally some differences (such as different reasons for choice of topic, time management, difficulties encountered, etc.) due to different nature of writing tasks, different writing requirements and different circumstances under which the assignments were done.

Similar to the conclusions made in Chapter 6, E1 and E2's different experiences of doing this second assignment appeared to largely result from their different attitudes toward learning and reading and from their different self-images. For example, E1's self-confidence as a previously top student made her delay the start of working on her assignment, leading to a time management disaster which she had never experienced before; her opportunistic choice of the topic—choosing the topic because it involved fewer teaching sessions than the other choice—turned out to require more effort from her than the other topic might do, because she found the lectures on her chosen topic were boring and unenlightening, the lecture notes were seen as not informative, and she never read pre-readings so that she had to learn everything on her own (see 6.3.1.1 above). E2 did not have E1's trouble because E2 chose the topic that she knew better than the other one; she read all the pre-readings before each session; she left enough time for the assignment; she sought help from her tutors actively; and so on. Always

being an average student, E2 felt that she could not take any shortcut like E1.

Unlike the assignment for the IER module, which both E1 and E2 completed successfully without much trouble, the TLA module assignment revealed some difficulties and problems that E1 and E2 encountered, which were absent while doing the IER assignment. One would have assumed that as time went by, the students should get more and more used to their new study environment and experience less and less trouble. In fact, E1 and E2's stories indicate that that will not necessarily be the case. Instead, whether students' experiences of learning, reading and writing assignments are smooth or difficult seems to depend firstly on their past experiences and personal characters, which determine their attitude and approach to the reading and writing tasks; secondly on the amount of support available to the students to help them get the work done satisfactorily. The analysis of the relationships between the 'subject' and other components of the activity system suggests that the mismatch of the expectations between the students and tutors may possibly be resolved only by avoiding taking anything for granted and by taking more effort and responsibility on the parts of both students and tutors. For example, Chinese students might be more sensitive to possible differences in the task requirements and communicate with the tutors about anything that they are not sure, while the tutors might make further effort to understand Chinese students' needs, which may likely be different from home students. This might take the form of reminding the students of their time management—it may be a few words before the end of a session, or a few lines of email message, that may call students' attention to the deadline and their working schedule, and may thus make an important difference to the students' learning experience. It is perhaps in such "minor" details as well as in terms of larger, more obvious "structural" features of the system that the potential for maximising successful learning outcomes may occur.

It also seems evident that the emotional aspect of students' reading and writing practices should not be ignored since it influenced a great deal E1 and E2's experiences and assignment results. Similar to the IER module assignment in Chapter 6, during the course of doing the TLA module assignment, E1 and E2 also had a desire to seek a sense of security and certainty from the process of reading so that they could produce a satisfactory piece of written work. However, E1's process of seeking that sense of security and certainty was disrupted and disturbed due to various factors discussed in section 7.3.1.2 above, and she thus experienced quite a few unpleasant emotional changes, which made her unable to meet the deadline. In addition to the factors related to her personal characteristics, there were factors related to the MA programme, to the members of staff, and to the academic 'community' of Lancaster University, that prevented her from getting those positive emotions facilitating her reading practices. Pedagogical implications concerning this respect will be discussed further in the concluding chapter.

By using the NLS/AT framework to examine E1 and E2's experiences of doing the TLA module assignment, the analysis in this chapter has unfolded the details of their academic reading practices in doing another assignment (in comparison to Chapter 6), and demonstrated how different task requirements, different situational contexts, and different tutor-student relationships and interactions, can affect the students' academic reading experiences. This chapter has also demonstrated more clearly the inter-relatedness of academic reading and writing: e.g. writing tasks could not be fulfilled satisfactorily without reading the appropriate literature sufficiently; writing experience of earlier assignments and reading of tutor comments on those assignments influenced students' reading practices of later assignments (especially those which were similar to the earlier ones); readings were handled differently according to the purposes

they served in the writing. Thus, this chapter has once again illustrated the advantages of using the combined NLS/AT approach to gain more detailed insights into students' academic reading practices than when viewing reading solely in terms of a 'technical skills' perspective.

In the chapter that follows, I will discuss the cases of the two subjects in the MSc. in Management programme in a similar way to that in Chapters 6 and 7. In so doing, I will unfold a picture of students' academic reading practices in a different subject area in order to see to what extent their reading practices remain similar or become different across subject areas.



Chapter Eight: M1 and M2's Reading Practices in the MSc. in Management Activity System.....	272
8.1 Introduction .....	272
8.2 Construction of 'Object' in Reading Activities .....	273
8.2.1 Individual Essay for the 'Learning to Manage' Module.....	273
8.2.1.1 Understanding the Task and Choosing the Topic.....	274
8.2.1.2 Identifying and Searching the Readings .....	276
8.2.1.3 Reading and Integrating Reading into Writing .....	278
8.2.1.3.1 M1's Case.....	278
8.2.1.3.2 M2's Case.....	281
8.2.2 Group Project Report for the 'Economics for Managers' Module .....	283
8.2.2.1 Understanding the Task and Choosing the Topic.....	283
8.2.2.2 Identifying and Searching the Readings .....	287
8.2.2.3 Reading and Integrating Reading into Writing .....	288
8.2.2.4 Summary.....	290
8.3 A System View of Reading Practices—Components of the Activity System and the Relationship between Them.....	292
8.3.1 'Subject' .....	292
8.3.1.1 Personal History and Personal Difference .....	292
8.3.1.2 Emotional Aspect of Reading for Writing .....	294
8.3.2 'Subject' vs. 'Community' .....	296
8.3.2.1 Supportive Relationship—the Network of Support .....	297
8.3.2.2 Conflicts and Contradictions between 'Subject' and 'Community' .....	298
8.3.2.2.1 Competition and Conflicts between the Students .....	298
8.3.2.2.2 Conflicts and Contradictions between Students and Tutors.....	300
8.3.3 'Subject' vs. 'Rule' .....	308
8.3.4 'Subject' vs. 'Division of Labour' .....	309
8.4 Conclusion .....	310

## **Chapter Eight: M1 and M2's Reading Practices in the MSc. in Management Activity System**

### **8.1 Introduction**

In this chapter, I will explore the academic reading practices for writing assignments of M1 and M2, the two MSc. in Management subjects, by focusing on their experiences in this respect in relation to two courses that they both took in the first term, i.e. 'Learning to Manage' (LM) and 'Economics for Managers' (EM). This chapter as a whole contributes to the database of the research this thesis is concerned with by examining similar subject-matter to that in the previous two chapters, but within the context of the activity system of a different disciplinary area. In this way, it is possible to compare and contrast earlier data with those obtained in this part of the research, in order to see to what extent common patterns are found and to also see whether new and different trends emerge. Also, the purpose of exploring the processes of reading for

writing two assignments instead of just one assignment is, as was the case with E1 and E2, to see whether and how different the students' reading may be for doing assignments of different natures (as was the case with respect to those of the courses in question). The construction of the 'object' in the reading activities and the relationships between the elements of the activity system will be discussed in turn.

## **8.2 Construction of 'Object' in Reading Activities**

The following discussion of the process of constructing the 'object' of the reading activities aims to unfold the details of the subjects' reading practices for writing assignments. Generally speaking, M1 and M2's processes of reading turned out to consist of similar stages as E1 and E2's, which included choosing a topic, understanding the task, identifying and searching readings, reading, and integrating reading into writing (see 6.2.1, 6.3.1 and 7.2 above for E1 and E2's cases, and figure 7.1). In the following part, I will discuss M1 and M2's experiences in each stage in turn in order to identify the differences and similarities between the four cases during their processes of constructing the 'object'.

### **8.2.1 Individual Essay for the 'Learning to Manage' Module**

The first assignment discussed here was an essay of 2500 words for the 'Learning to Manage' (LM) module, which was to be turned in on the last day of the first term. The essay topics, requirements, tips, marking criteria, references, ways of referencing, and so on (see appendices 17, 25) were all given in the module booklet that was distributed at the beginning of the course. The marks received by M1 and M2 for this assignment were 50 and 57 (a bare and a high Pass) respectively. The written feedback they received from their tutors can be found in appendix 18, 19.

### **8.2.1.1 Understanding the Task and Choosing the Topic**

There were four topics for the students to choose from for this essay: organizational culture, teamwork, business ethics, and management learning (see appendix 17). M1 was most interested in the topic of 'business ethics'. However, personal interest was not the primary concern in his choice of topic. When he learned from a course mate that many students chose the topic of 'ethics', M1 decided not to choose it because he did not want to write about a topic that many others were writing on too (transc3:7). Therefore, he chose to write about 'teamwork', instead. Ironically, one week after he decided on the topic, another of his course mates told him that students from another programme who attended the same module with them had all chosen 'teamwork' as their topic. And later, M1 learned that quite a few students from his class had also chosen to write about this topic, by which time it was too late for him to change his mind (transc3:7). After the results were returned to the students, M1 found that as far as he was aware of, those who wrote about 'teamwork' generally got lower marks than those writing about other topics (transc4:1). This may or may not have been the case, but, unfortunately, I had no means to find out for certain because the course tutors did not summarize the students' results in this way (transst4/2:1).

M2 chose to write about 'organizational culture' because it was her interest - she had written her undergraduate dissertation on a topic related to culture, too. She felt that at least she had read something about 'culture' before, and she assumed that there might not be many people choosing this topic (transd2:5). She was also interested in 'teamwork', but she did not choose it because she felt it had been written about by too many people and had been studied too thoroughly (ibid.). M2 also had the feeling that most of her class mates also wrote about the same topic as she did when she talked with her course mates after getting their feedback of this assignment (transd2:5). Both M1

and M2 tended to feel that their topics were the ones most students wrote about, though my suspicion is that with a student population of over one hundred and with only four topics to choose from, whichever topic they chose, there would be many others writing about the same topic as they did. The subjects' unwillingness to choose the kind of topic that was popular with many of the students was a) because they felt that the literature for such topics was very large and therefore difficult to cover, and b) because they felt a topic being done by so many students would be difficult to come up with interesting and novel ideas for (transd2:5).

In terms of the writing requirements, both M1 and M2 were not very certain about what the tutors really wanted to see in their essays (transc4:1, transd6:8). M1 discussed the matter with other students who wrote about 'teamwork', but none of them seemed sure about the requirements (transc4:1). One of his course mates asked for the tutor's clarification, which did not seem to help much (transc4:1). M2 emailed her tutor, asking for the clarification of the 'purpose' of writing this essay, but got no reply (transd6:8). M1 complained that the tutor of this module did not talk about the assignment in class as some other tutors did: as he said,

The tutor for the 'Operations Management' module spent half a session explaining the assignment requirements and from time to time also mentioned in other sessions how to do the assignment. The 'Economics for Managers' (EM) module tutor also spent about 20 minutes on discussing the assignment in one of his sessions. ... Only the LM module tutor did not seem willing to talk about it (transc4:4).

As for students' questions, according to M1, this particular tutor only gave very simple answers (transc4:4). And M2 reported that she got no reply from this tutor when she emailed her (transd6:8). It seems that both M1 and M2 sought for help in understanding the task when they found it difficult to figure it out on their own. However, they were not successful in getting sufficient help. Feedback from their markers also seems to confirm that the students did not end up producing what the tutors had expected to see in their essays (appendices 18, 19, transst6:3, transst4/2:9-10) (also

see 8.3.2.2.2 and 8.3.3 below).

Comparison with E1 and E2's cases further indicates that a good understanding of the task was very crucial to the successful fulfilment of an assignment. For example, E1, while doing her assignment for the IER module, could fully understand tutors' expectations for this assignment, which appeared to contribute to her producing a piece of work that both the marker and herself were satisfied with (see 6.2.1.1 above). In contrast, E2 always sought help from her tutors when she was not sure about the writing requirements or anything else, and the tutors' advice she got very often clarified things that she might not be able to figure out on her own, thus saving her much time and trouble in her experiences of doing her assignments (see 6.3.1, 7.2.2 above). Sometimes, E1's own understanding of task requirements yielded better results than E2, who relied more on tutors' clarification and advice, as the latter may not always catch the tutors' point exactly; sometimes it was the other way round. All four subjects' experiences seemed to indicate that achieving a good understanding of the writing requirements, no matter how such understanding was reached, was important for satisfactory results. Further discussion about student and tutor relationships and their impact on students' experiences will be undertaken later (see 8.3.2.2.2, 8.3.3, 8.3.4 below).

### ***8.2.1.2 Identifying and Searching the Readings***

Although M1 and M2 did not properly understand the tutor's expectations for the LM essay, they felt that the essay questions designed by the tutor provided them with a fairly clear direction for searching the relevant readings (transc3:3, transd2:6). For example, M1's question was as follows:

According to Flores and Grey (2000) in 2000, 80% of all Fortune 2000 companies had over half their employees working in teams. Indicate what "working in teams" means, the complexities of teamwork and why team based work is such a widespread phenomenon (appendix 17).

Since the topic was 'teamwork', M1 knew that he should borrow books from the library

on 'teamwork' for theories in this area (transc3:3). However, he could not find any of them because they were all borrowed by his course mates. He learned from a course mate that all the books had already been taken out two weeks previously (transc3:3). However, unlike E1, who ran into great trouble when she could not get hold of any reference books because she started too late and had to ask for an extension for that assignment, M1 was not worried about lack of reference books, since there was a textbook, which was set by the tutor to be the only reference book needed for this assignment (transc3:3, transst4:2). M1 borrowed this textbook from his course mate and copied the relevant chapters. He also searched the Internet for some articles on his topic, which he thought would be enough for this essay (transc3:3). His understanding was confirmed by his marker in the assignment feedback, who commented that "This essay presents a complete view on team and teamworking literature as developed in modern organizations. Definition of team, developments phases, roles, etc. are fully provided" (appendix 18).

M2 was also able to identify readings according to the essay question: 'What is organizational culture? Is managing culture ever possible?' (appendix 17). Like M1, M2 was also fully aware of the tutor's reading requirements for this module. As she said:

因为老师说的是你论文也好，考试也好，你最主要是根据这本书的，就说你得把这本书读懂了读通了，你再看其他的。但是呢如果你想得高分呢，你就必须得参考尽可能多的资料。所以我两边都要兼顾。

Because the tutor has said that you should base both your essay and exam preparation on this book, and read other things only after you fully understand this book; but if you want to get high marks, you have to read as much as you can. Therefore, I have to take into consideration both aspects, i.e. reading of the textbook and reading of other references (transd2:7).

Therefore, M2 knew that the textbook was the main thing she should study, but she also did a 'keyword' search in the library catalogue for other books on 'organizational culture'. She also looked for books on management strategies since she thought managing culture might involve these as well (transd2:6). Apart from university library resources, M2 searched the Internet for articles both in Chinese and English (transd2:6).

However, the tutor was not quite satisfied with the way M2 used the literature, commenting in an interview that

She used this source, which is great source (sic). But it's one of the other things... We probably haven't even talked about his work in the textbook. In the textbook, we have developed a huge set of arguments that could support that (M2's point). Why is it that she didn't engage with that? You can tell. Because you see this Anthony, so she has done some work. But this isn't the point we discussed for ages. Why is it they are not here? ...I could have taken any student from management, undergraduate, they know Anthony's work, so they could have written me something like that about culture (transst4/2:10-11, my interpolation).

In other words, the tutor felt that M2 had made insufficient use of the main textbook she had recommended. M2 herself admitted that she had planned to use this textbook as her main reference, but as she wrote, she was inevitably and unconsciously directed by the other reference materials that she found (transd6:8). Another criticism the tutor had was of E2's use of Internet sources, which she regarded as unreliable (appendix 19). In the tutor's opinion, "The fact that you use someone who wrote something and posted it on the Internet doesn't make it an authoritative reference to use, unless it's obviously recognized and relevant e-journal or university website or company website" (transst4/2:7).

To sum up, the essay questions for this assignment and the tutor's explicitly stated reading requirements for this course helped M1 and M2 identify and search for the relevant readings. However, even with the right reference materials, as M2's case shows, students may not be able to use them in the way that the tutor would like them to.

### **8.2.1.3 Reading and Integrating Reading into Writing**

As relevant parts of the account of E1 and E2's reading practices showed, they dealt with readings differently according to the purposes they served in the writing (see 6.2.1.4, 6.2.1.5, 6.3.1.3, 6.3.1.4 and 7.2.4 above). The same is true with M1 and M2. I will describe this aspect of M1 and M2's cases in turn in what follows.

#### **8.2.1.3.1 M1's Case**

M1 spent only three days on this assignment—from searching for the readings to finishing writing. He was preoccupied with other assignments as well, particularly the course work for ‘Project Management’<sup>1</sup>, for which he had to meet his group members every day, and which left him with little time for the LM module essay (transc4:1). He started by reading the main textbook since the tutor emphasized that they should focus on it (transc3:3, 6). The essay question had indicated that the essay should cover three main points, i.e. what is teamwork, the complexity of teams, and the reasons why teamwork is so widespread (see 8.2.1.2 above). In addition to covering these parts, M1 also wanted to add other parts, dealing with case studies of team-work and his experience of working in teams (transc3:3). Reading the textbook helped him plan a detailed outline for the essay (transc3:3). As he read, he underlined the points that might become part of the outline; he typed into the computer sentences that he might quote, with a note of the page numbers in the textbook that they came from, and in which part of the essay they could be used (transc3:3-4). There was another book that was recommended by the tutor for the session when they covered ‘teamwork’. M1 read it during the term time, and it functioned similarly as the textbook did—to help him construct the outline of the essay (transc3:5). Meanwhile, he was searching and reading articles for ideas that he could put under each heading of his outline, and also for cases of teamwork that he could analyse in the essay (transc3:3, 5). He usually looked first at the abstract to decide whether it was worth reading. Then he would browse the headings and subheadings and read the first couple of sentences of each part to see if they might be useful in the essay; and if they were, he read the relevant parts again when he came to write the corresponding parts of the essay (transc3:4, 5). He had, since his

---

<sup>1</sup> The time spent on this course work, which was more than the sum of the time spent on all his other pieces of course work in term 1, was well worth it because M1's group got the highest mark among the students in his class, and he felt he learned a lot in this course and by doing this course work (transc4:1-2).



undergraduate years, had the habit of going through all the reference materials once before he decided on the final outline and what materials he might be able to use in the essay, whereas some of his course mates thought his was a very time consuming way of doing it and they would rather write as they read to save time (transc3:4). Even if he did decide to read some materials again, he would not read from the beginning to the end. Instead, he read the first few sentences right under the heading, and skipped those irrelevant parts.

Because of lack of time, he had to start writing before he could fully understand what he was reading (transc4:1). He knew that the tutor expected them to write something about “Post-Taylorism”, but he did not do that because he did not fully understand it and did not have time to read more about it (transc4:1-2). After he wrote some parts of the essay, he found that he had already exceeded the word limit before he got to the last part, which was about his experience of teamworking. Although he knew he should have cut things out to make room for the last part, he did not have time to do so. He was barely able to meet the deadline, finishing half an hour before the deadline. Therefore, it was not surprising that he did not have time to reflect on his reading and writing before turning the essay in. His marker's comments also seem to spot this problem. The marker, though approving of the literature M1 used (see 8.2.1.2 above, and appendix 18), further commented that “the essay appears as being a collection of points and themes only loosely connected, without offering in other words to the reader an organic view or demonstrating a clear and personal line of thinking deployed by the author” (appendix 18). M1 admitted that he did not think about the problem that the marker pointed out to him while he was writing due to the shortage of time. Upon reading the tutor's feedback, M1 thought that in the future, he would try to understand more thoroughly what he read and to consider the connection between different theories

he would use in the essay, instead of simply quoting things that appeared to be relevant at first sight (transc4:4). M1's attitude towards tutor feedback again indicates the inter-connection between reading and writing—reading of tutor feedback influenced his later writing practices (cf. 6.2.2, 6.3.2 and 7.4 above).

#### **8.2.1.3.2 M2's Case**

Although M2 started working on this assignment about a week before the deadline, which did not make her feel too pressurized while doing it, she also mentioned that it was not possible for her to spend much time on each piece of work in term 1 because there were so many deadlines to meet and she had to rush to finish one piece and started rushing through the next one (transd2:3). That was partly why she could not spend much time reading according to M2 (transd2:3, 7).

Unlike M1, who started writing after he went through all the readings, M2 wrote as she read. As she divided the essay into two main sections, i.e., the definition of 'organizational culture' and whether 'organizational culture' can be managed, she read the materials about the definition aspect and wrote the corresponding part before she read anything on manageability of 'organizational culture' (transd2:5). But she also reported that she had to finish readings for each section in order to have an overall idea of what and how to write (transd2:3).

The chapter on 'organizational change' in the textbook in question was the first thing M2 read. While reading, she followed the habit she developed while she took the university summer study skills course (see 5.3.3.1 above), making notes and marks in the text or notebook to indicate to herself how she might use certain parts of it in her essay (e.g. by quoting, paraphrasing, using as an example, etc.). As she read, she also summarized the characteristics of 'organizational culture' in her notebook (to be developed more fully when she used the information in the actual writing of her essay)

(transd2:3). Because of the time constraint, she only read through the chapter on 'organizational change' once and skipped contents that she thought irrelevant, such as case studies and examples that she would not use in her essay, though she would spend a little longer time on the parts she needed to summarize (transd2:6-7). Besides the notes she made on the notebook or in the texts, she sometimes copied directly into the essay sentences from the readings that she thought would be part of the essay, or sometimes she wrote down in the essay, rather than in the notebook, an idea that suddenly occurred to her during reading, together with some notes to remind her of the intended use of the quotations or ideas (transd2:4). Another book she read mainly provided her with a suitable case study to support her arguments (transd2:3). She also used quite a few Internet sources, some of which she did not even know the name of the author. She also did a keyword search in a few search engines (see 8.2.1.2 above) and the way she read these reference materials was simply to browse them, and copy down relevant opinions and ideas into her essay whenever she spotted them. Her biggest concern was to finish writing the assignment as soon as possible because there was other work awaiting to be finished (transd2:3). Therefore, when she read, she only cared about how to use what she read in her writing, though she had to understand what she read in the first place. After putting everything that she summarized into the essay, she did not have a second thought about what she had written (transd2:4, transd6:2).

In her feedback, the marker pointed out to M2 that she "could have engaged more closely with the issues and the ideas discussed during the course and in your textbook in order to go in depth into the subject matter" (appendix 19). In fact, M2 was aware that the textbook was the main reference materials (transd2:7). Yet as she wrote, she unconsciously neglected the textbook and was led more and more by references that she found by herself (transd6:8). The fact that she did not look back at her writing before

handing it in may also have prevented her from seeing her problem. Or even if she had discovered the problem, she might not have had time to solve it. M2 also thought that her essay had no depth (transd6:4), the reason for which she believed was that “lack of time resulted in the limited range of readings one could cover, which in turn resulted in the lack of depth of what one could write (transd6:7).”

There will be a brief summary of M1 and M2's experiences of doing their LM assignments at the end of section 8.2 below.

### **8.2.2 Group Project Report for the 'Economics for Managers' Module**

For the "Economics for Managers" (EM) module assignment, the students were required to work in groups allocated by the tutors, to carry out a project on one of the six topics provided by the tutors and to write a report of maximum 5000 word (see appendix 21 for details). The module lecturer listed the requirements on the board in one of the course sessions and distributed written copies of project topics and requirements (transst5/2:1, also see appendix 21), and he invited students to consult him in person or via email about questions on the assignment (transst5:5-6). The marks received for M1 and M2's groups were 56 and 62 (see appendices 22, 23 for written feedback from the markers).

#### **8.2.2.1 Understanding the Task and Choosing the Topic**

Because this was a group project, the choice of topic and the understanding of the task involved more complexity than an individual essay did. According to M2, their group, for example, decided to choose a topic that was relevant to the two countries that the members came from, i.e. China and India, that was “hot” for both countries and the world as a whole, and that was interesting to all of them. They felt that ‘free trade<sup>2</sup>’ met

---

<sup>2</sup> Topic 5 in appendix 21: “Free trade is beneficial only if your country is strong enough to be able to stand up to

all these criteria (transd2:1). However, they did not make their final decision until after they searched the Internet to make sure that there were plenty materials on this topic available (transd2:1). M1's group chose their topic<sup>3</sup> simply because the majority of the members, namely two of them, were interested in it, and each of the other two members was interested in different topics, hence complying with the majority (transc3:1). It therefore seems that in working out a suitable topic for the group as a whole there were more factors that they needed to consider than for the individual work.

With regard to understanding of the task, M1's group reached the decision that they would use one chapter to describe the current situation in British supermarket retailing (the data), and the other two chapters to analyse the market of British supermarkets using certain theories (economics analysis of the market and policy) (transc5:1, my interpolation). The lecturer of the EM module talked about his expectation while commenting on M3<sup>4</sup>'s group report:

They collected data; they used economics analysis; and they brought these two together to evaluate the nature of the market structure, conduct and performance; and then brought up policy implications. And that's exactly what I wanted (transst5/2:4).

This seems to indicate that the understanding of the task by M1's group was quite close to the tutor's expectations. However, correct understanding of the task may not guarantee a desirable outcome, especially when the task is carried out by a group. Thus, in the same interview, the lecturer also commented on M1's group work by saying "there's not a great deal of economics in this project. (It is) very descriptive (transst5/2:2)". According to M1, the first chapter—the description—was done by all four group members, and was viewed as a good description by the marker (appendix 22). They discussed during the meetings how to write the next two chapters and what theories to use (transc5:1). The British student in his group suggested that he should do

---

foreign competition". Discuss and evaluate this statement (make use of examples and/or case studies).

<sup>3</sup> Topic 3 in appendix 21: With reference to a particular sector (e.g. banking, retailing, etc.), describe the market structure, the conduct and performance of firms in that sector and the implications for competition policy.

<sup>4</sup> A student in the MSc. in Management programme that I interviewed but not reported in the thesis.

the remaining two chapters on the basis of the group discussion. Since the other three members had all chosen an elective course, the course work of which was very time-consuming, they accepted the British student's offer (transc5:1). Another reason that their British group member insisted in writing by himself was that he apparently did not think Chinese students can write well (transc5:2). The British student was not the only one holding such an opinion according to M1's experiences of group work (ibid.). Though M1 and the other two group members were a bit worried about what their British group member would write, they could not possibly check the report because it was not completed until the last night before the deadline<sup>5</sup>. According to the marker's comments quoted above, apparently the British member of M1's group did not write in accordance with the understanding of the task that the group had reached. Or he may have simply ignored the group understanding and imposed his personal ideas onto the whole group as he was in charge of writing. M1 said they all trusted their British group member to write the report following the decisions made by the whole group. Yet in reality, they had little control over what was actually written in the report, especially when it was completed only very shortly before the deadline. However, it can be argued that M1 and other group members were also to be blamed for neglecting their share of duty in the writing, even though the British member insisted on writing on his own and they had many other deadlines to meet. This case suggests that even with a correct understanding of the task, the students may not be able to produce a satisfactory group report due to the complexities involved in working out a satisfactory group "*modus operandi*".

M2's group did not seem to worry much about the writing requirements, or in other

---

<sup>5</sup> As M1 said in an interview, "I asked him (the British student) to send me the part he has written the night before the deadline. He said, 'you have to wait for a while because I am writing chapter two at the moment.' ... I was the only one, besides him, who read the whole report before it was turned in. ... I was a bit worried because it seems that he did not include what we decided to include in our meetings... (transc5:2, my interpolation)."

words, what the tutor expected to see in the report (transd7:2-3). Thus, according to M2, they did not talk about the structure of the whole report and how each section should be written (ibid.). All they worried about was whether they could find enough reference materials and whether they could finish on time (ibid.). During the meetings, they discussed and decided that each of the four members would write one section, whereas what each section would contain was more or less determined by the reference materials they could get (transd2:1). They finally came to decide that an Indian student would write about the influence of free trade in India, M2's part was to be about the influence of free trade in Chinese textile industry, another Chinese student would talk about free trade and Chinese agriculture, and the last member—another Chinese student - would write something general about free trade. However, they did not discuss the overall structure of the report and how each section should be structured or what each section should contain (transd7:2-3). The tutor commented on their work that it was

not exactly the kind of analysis ... It didn't offer much of empirical studies ... for instance, (using) some sort of data ... to show what happened to the volume of investment within the volume of trade between the western and the less developed economies... If you talk about reduction of tariff, how that has affected manufacturing (transst7:4-5, my interpolation).

It is not surprising to see such comments if one thinks about the fact that M2 and her group members did not even discuss what the analysis in the report should look like. M2 also admitted that while reading reference materials, she never bothered to look at how the authors structured the essay, or analysed the data, because she was so short of time (transd7:2). The marker spotted exactly the same problem in their report and commented that

they have mentioned lots of works of economists. But it was more of the name dropping, rather than actually having looked at any of the works, which I think if they had, it would make the work much deeper analysis (sic). ... they could have done better in terms of the use of literature, the use of empirical work... and also in terms of the structure... (transst7:4).

Both M1 and M2's experiences in doing this assignment indicate the importance of proper understanding of the task, echoing with the discussion in 8.2.1.1 above concerning the understanding of the task in their LM module assignment. The

difference here lay in the complexity of group work, which required not only the correct understanding of the task, but also the effective operationalization of the understanding among all the group members to produce a satisfactory piece of work.

### **8.2.2.2 Identifying and Searching the Readings**

Because of the nature of group work, i.e. group members share the work, M1 and M2 only searched the readings for the part that they were in charge of, rather than for the whole group project. In M1's group, the report was divided into three chapters—one chapter for description of four major UK retailing supermarkets and the other two for analysis of the market structure, conduct and performance (transc3:1-2, transc5:1, also see 8.2.2.1 above). The description chapter was divided among all four members, so M1 was responsible for the information about one supermarket - Sainsbury's (transc3:1). The lecturer provided a website relevant to the analysis of their chosen topic, but M1 did not search it. What he was looking for was the information about the company over the last five years, such as the market share. He focused his search on the library e-database for articles with relevant information about Sainsbury's. He looked at about 30 - 40 articles but found very little useful information until he found a database especially designed for searching company profiles, where he got all the information he needed and also helped other group members to get their relevant profiles. M1 did not think it necessary for him to search anything else, as the British student in the group took the responsibility for writing the other two chapters (transc3:1-2), though another group member did read about the theories which was not her part of work and which contributed to the group discussion of the other two chapters (transc5:1).

In M2's case, the tutor recommended some references for the students who chose the topic of 'free trade'. However, M2 could only get two books among the recommended list, which were not really relevant to the part she was writing (transd2:1).



Since during the group meetings, they did not discuss how each person should write his/her part, M2 decided to write about both theory and case studies, even though other members might use a different approach (transd7:2). In order to write in her chosen way, M2 used the keyword search in the library and got several books and journal articles. She also used various search engines (e.g., Google) to get information from the Internet (transd2:1-2).

Both tutors who marked the two group reports gave positive feedback concerning the readings that M1 and M2 located. M1's marker commented that their work offered "an interesting description of recent events in British supermarket retailing and a good account of each company's position and strategy" (appendix 22), which was largely based on the information that M1 found in the company profile database. M2's marker remarked that "the use of literature was adequate" (transst7:4), which included the literature that M2 found and used.

### ***8.2.2.3 Reading and Integrating Reading into Writing***

Both M1 and M2 read less for this group report than for the individual essay discussed in 8.2.1 above. M1 was responsible for a 400-word description of the supermarket - Sainsbury's. He mainly looked for some statistics of the market share of the company over the past five years (transc3:1). It took him quite some time to find the right database for the statistics because he had to try various websites in the library e-database, and he also went through quite a few electronic versions of some newspapers (transc3:1-2). The reading itself was simple since he only needed to extract the statistics and put them together to show the fluctuation of the market share of this company (transc3:1-2). The tutor's comment on M1's part was positive by saying they offered "an interesting description" (appendix 22).

In M2's group, each member was allocated about 1000 words to write. M2's part

was about the effect of free trade on the Chinese textile industry and on developed countries like the US (transd2:1). She mainly read the textbook for the theories of free trade and two journal articles for case studies to support her opinions (transd2:2, 8). She read the textbook in a way similar to how she read the textbook for the LM module assignment, marking the text, making notes and summarizing (transd2:2). M2 reported that during the group discussions, each group member had already formed some rough idea of the main arguments for his/her respective part. When she read the textbook, she found that the ideas she was going to write about were already expressed in it. And so she could use this as a source of evidence or theoretical basis for her arguments (transd2:2). As for the two articles (one from a journal in the library and the other from an Internet source), she simply focused on the two case studies, which were quite short and easy to read, and for which she did not need to make notes in the notebook (transd2:8). She used the cases to show the impact of free trade on aspects such as the competition of a certain industry, the development of that industry, etc. in both developing and developed countries (transd2:3, 8). Since she could only write 1000 words, M2 did not think she should read any more (transd2:3).

It seems that M2 had done what the tutors were asking the students to do, by talking about the theory and analysing case studies. Yet the tutor still commented that they did not “offer much on empirical studies on free trade” (appendix 23). The reason for this may lie in the different understanding of empirical studies and the way to analyse them on the part of the tutor vs. the students, which will be discussed more fully in 8.3 below. In the section that follows, I will briefly summarize M1 and M2's experiences of doing the two assignments in terms of the construction of the ‘object’ in the activity system of the MSc. programme, including comparing them with E1 and E2's parallel experiences.

#### **8.2.2.4 Summary**

M1 and M2's cases of doing the two assignments again seem to confirm that there were some basic stages in the process of construction of the 'object' of the reading activities for writing (see figure 7.1 above). Like E1 and E2, M1 and M2 also felt they needed to understand the writing tasks in order to identify and search the relevant readings, to choose a topic when there was a choice for them to make, to read according to the purposes of using the readings in the writing, and to integrate reading into writing. The 'object' of reading activities here was again similar to that of E1 and E2, i.e. to enable the readers to use the readings to produce a piece of writing. During the course of reading, how briefly or carefully they read, whether and how they made notes, etc. mostly depended on the ways in which the readings were integrated into their writings. The cases of the four subjects all indicate that academic reading for the purpose of writing assignments not only involves reading of academic texts, but also reading of lecture handouts, assignment guidelines, tutor comments and the like; and that academic reading and writing are so closely related to each other that a study of reading inevitably involves many aspects of writing.

The four cases all seem to suggest that how successful the assignments were depended, to a great extent, on how well the students did at each stage of the whole process. At each stage, there were usually a variety of factors that had an effect on the way students handled the tasks involved in the stage in question. For example, in earlier sections, I have tried to show how student's past literacy practices, personal interests, purpose of learning, etc. played a role in the choice of topic for writing (see 6.2.1.3, 6.3.1.1, 7.2.1, 8.2.1.1, and 8.2.2.1 above), the effort and time invested in the reading and writing (see 6.2.1, 6.3.1, and 7.2 above), the way readings were handled (see 6.2.1, 6.3.1.3, 6.3.1.4, 7.2.4, 8.2.1.3, and 8.2.2.3 above), the way help and support were sought

(see 6.4.2, 7.3.2, and 8.3.2 above), and so on. Tutors' availability, helpfulness, and promptness in reply to students' questions, the explicitness and thoroughness of the assignment guidelines, the usefulness of lectures and lecture handouts, and so on, all made great difference in students' experiences of reading and writing (see 6.4.2, 7.3.2, 8.3.2, 8.3.3 and 8.3.4 above).

Differences between the two master's programmes also existed. For instance, a big difference between the MA in Education programme and MSc. in Management Programme was that Management students had a far more intensive timetable than the Education students<sup>6</sup>, which meant that M1 and M2 were allowed much less time to concentrate on each piece of course work than E1 and E2 were. That seemed to partly explain why M1 and M2 did not have time to understand the writing tasks as fully as E1 and E2 did for the 'Introduction to Educational Research' (IER) module assignment, or to understand the readings better before they had to start writing, or to reflect on and revise what they had written before turning it in even if they did notice something wrong with their writings. The fact that many of the pieces of course work for Management students were group projects added to the uncertainty of the outcomes of these items because one may not possibly predict whether all the members would understand the tasks in a similar way, would follow the group decisions, would finish work by the proposed time, would turn up for group meetings, and so on. There will be more detailed discussion of this aspect in 8.4 below, where the implications of the findings will also be discussed.

---

<sup>6</sup> Take the first term for example: E1 and E2 had two courses plus a 'study skills' course, whereas M1 and M2 had four compulsory courses plus one optional course (transc2:8). In addition, the assessment of each course in the MSc. in Management programme usually involved an individual essay or report, a group project and an exam; whereas in the MA in Education programme, the 'study skills' course was not assessed, and the assessment for the other two courses involved two essays each.

### **8.3 A System View of Reading Practices—Components of the Activity System and the Relationship between Them**

In this part, I will look at the reading practices from a system view by exploring the components of the MSc. in Management activity system (AS) and the conflicts and contradictions within and between the components, with a view to identifying factors that contributed to the students' current reading practices and their experiences of studying in the MSc. programme.

#### **8.3.1 'Subject'**

The 'subject', as the agent in the activity system, plays a most important role in the construction of the 'object', hence it is worth singling out for a closer look. Here, in this connection, I am going to talk about the influence of personal history and personal difference on M1 and M2's reading practices. Following that, there will be a discussion of the emotional aspect of their reading practices, and its effects.

##### ***8.3.1.1 Personal History and Personal Difference***

In 7.3.1.1 above, I talked about E1's difficult experience in doing the 'Teaching, Learning and Assessment' (TLA) assignment, caused mainly by her late start, which meant that all the reference books had already been borrowed by other students. She went through dramatic emotional ups and downs during the course of doing that assignment, and finally got the work done with the help of a two-week extension (see 7.3.1 above). M1 faced a situation similar to E1's when he started working on the essay for the LM module three days before the deadline—he could not find a single book in the library on the chosen topic. However, unlike E1, M1 still managed to submit the essay on time. One obvious reason could be the difference in the reading and writing requirements for the two assignments (see 7.2.2 and 8.2.1.2 above for details). I would still argue that the personal attitude towards learning in general and in academic reading

also played a decisive role in making the striking differences between the experiences of the two of them. E1 started late because it was her habit to put things off till the last minute, and she had not experienced any failure in the past by starting late. Her image of herself as an intelligent and good student gave her the confidence to finish work in a short period time. At the time when E1 started working on her assignment, she knew virtually nothing about the topic she was going to write on because she had never read any of the pre-readings assigned by the tutor during term time, she seldom paid attention to the lectures, and she did not find the handouts made much sense in helping her understand the topic. At the same time, she was so shocked and frustrated by the failing result of an earlier assignment, on which she also spent very little time, that she totally lost the confidence and could not work properly on the TLA assignment for some time (see 7.3.1 above). In M1's case, however, he did not start late because of bad time management. Instead, it was because he was occupied by a group project of an elective course which was very time-consuming (transc4:1). In fact, he was very well-organized, so much so that he managed to read most of the pre-readings for various courses before attending the lectures (see 5.3.3.2 above). He had always been a diligent student who tried to fulfil the reading requirements since his undergraduate years (see 4.4.3 above). Therefore, when he started working on the assignment for the LM module, he was not totally ignorant of his chosen topic because he had done some reading on it during term time. Besides the main textbook, he also read another book recommended by the tutor during the term (transc3:5). Although the time constraint had an obvious effect on the quality of his work (see 8.2.1 above), he nevertheless completed it on time and got 50 (the minimum pass mark) and had a far smoother experience in terms of emotional changes than E1 did.

M1 and E1's cases seem to suggest that personal history of literacy practices and

learning experiences and the personal attitudes towards learning that have developed over the years of their education had a clear influence on their current reading practices and learning experiences. Some of these students' usual past practices still made sense in the new contexts and helped them to read and learn in relevant ways. For example, M1's ability to manage time well and his habit of trying to do the required reading as much as possible enabled him to work under pressure better than E1 when both of them were facing similar situation. E2's habit of following tutors' reading requirements, regardless of her personal interest and the difficulty of the readings, largely prevented her from falling into the situation that E1 had to face while doing the TLA assignment; her trust in tutors' advice rather than in her own judgement led to her active communication with tutors for whatever questions she had about her assignments, which saved her much trouble and time for figuring out those problems on her own (see 6.3.1 and 7.2 above). However, not all past practices were useful in the new contexts, as was evident in the case of E1's TLA assignment. For students such as E1, thus, it may be advisable for the tutors to remind the students constantly of not taking things for granted without considering the changing contexts in which they were now pursuing their studies; and meanwhile, tutors might also be more aware that some of the students were from a different education background and might not be familiar with the academic literacy practices in the UK universities.

### ***8.3.1.2 Emotional Aspect of Reading for Writing***

During the course of doing their two assignments, both M1 and M2 had the feeling that time was always very pressing and that they had always to be on the go, rushing through one assignment to another (transc4:6, transd2:3, 7). M2 reported that she had to read and write at a much faster pace than she used to do in China, as she said "in China, I could only write a couple of hundred words a day. It was not possible to work at that

speed here. I wrote about five/six hundred words this afternoon and was aiming to write another five/six hundred at night” (transd2:5). It seemed that the time pressure made M2 more efficient in her reading and writing, which was not a negative effect. However, such time pressure did sometimes make the students feel frustrated, anxious and worried, especially when the other group members could not finish their work by a proposed time or did not turn up at meetings. For instance, one of M2's group members was especially slow in her work and her part was all raw data copied from one source or another. Because she was due to leave for home in the near future, other members of the group were therefore worried about her part of the work being finished unsatisfactorily or containing anything that might be considered as plagiarism (transd7:1-2). Although the other members would not be penalized for plagiarism, M2 thought the overall mark would nevertheless be negatively affected by anything of this kind (transd7:2). Another group member who was in charge of the revision of the whole report also left for her home country before the work was submitted. And the revised version was not sent back to M2 until five o'clock in the morning on the day the work was due. M2 had to add an introduction at the last minute and handed it in hastily (transd7:1). Similar anxiety and worry was also experienced by M1 and his group members when the member who was responsible for writing the analysis chapters of the assignment could not show them the final work before submission, which made it impossible for them to check whether the chapters were written according to the group discussion (transc5:2). Therefore, besides the time pressure M1 and M2 felt while reading and writing their individual work and their part of the group report, they also had to handle the anxiety and frustration brought about in various ways by other group members.

M2 had another great concern that made her restless throughout the process of doing the assignments—the fear of being charged with plagiarism (transd2:4-6). M2



mentioned that they had got several emails reminding them of the problem of plagiarism and consequences of being caught as plagiarizing, so that she was constantly worried about this problem (transd2:6). According to her,

不过国内不一样，都东拼西凑的那种，在这边就不行了，你真的得自己理解，自己去解释，自己去 paraphrase。你 paraphrase 还要做到避免 plagiarism...我们那个老师说我们只要 paraphrase 的任何东西全都要标明出处，但是很多时候，我们有时候自己也会有那种想法，但是看起来象是 paraphrase 它的，然后那个老师还说你要是想到什么观点呢，你最好到网上搜一下，可能一搜，那个是谁已经得出的理论了，这你也要标出来...反正我就觉得蛮郁闷的。

In China, one simply copied from one source or another and put them together, which would not be acceptable here. You have to really understand and try to interpret and paraphrase by yourself. When you paraphrase, you have to avoid plagiarism. One of our tutors said we needed to give a reference for everything we paraphrased. But very often, during the course of reading, we do form our own ideas which may look like something that is paraphrased from someone else. The tutor said whenever you have any idea, you'd better search in the Internet, because very likely it has already been said by someone else, and you have to make a reference for that too. ... Anyway, I feel very frustrated (transd2:4).

In M2's previous experience, plagiarism was not something that the tutors would seriously warn the students to avoid, so that M2 could feel free to copy others' ideas without proper referencing them. The tutors' totally different attitude toward plagiarism in UK higher education made M2 feel at a loss and extremely worried because she was not quite sure what counted as plagiarism, which constituted a great source of concern and anxiety for her. Fear of committing plagiarism appeared to be M2's strongest emotion during the process of reading and writing the two assignments discussed here.

The discussion in this part indicates that the process of doing assignments not only put the students' academic and intellectual capacity under test, but also their emotional strength. What tutors could do to help students is, as one of the tutors said "to try to diminish the anxiety, because anxiety doesn't help" (transst4:6). There will be further discussion on ways in which the members of staff might help the students in Chapter 9.

### 8.3.2 'Subject' vs. 'Community'

The relationship between the 'subject' and 'community' consists of the relationship between the students, and that between the students and the members of staff. I will discuss both positive aspects of the relationship which helped to make the 'subject's'

experience of reading for writing smoother and easier, and negative aspects that may contribute to the difficulties and problems that the 'subject' experienced during the process of reading for writing.

### **8.3.2.1 Supportive Relationship—the Network of Support**

During the course of doing the two assignments, both M1 and M2 discussed with some course mates about the problems they faced; M1 was able to borrow a textbook for the LM module from his course mate to make his own copy when he could not get it from the library; M2 managed to get a course mate to check her writing before handing it in (transd6:2). For the group project reports, group members usually helped each other in searching for relevant literature and exchanged the readings they found that might be useful to other members (transc3:1, transd2:1).

Support from the tutors included detailed written guidelines for the assignment that the LM convener prepared as part of the course booklet, where the students can find the essay questions, marking criteria, essay tips, and important notes (see appendix 17). However, it seemed that the students may have either neglected the guidelines or had difficulty fully understanding them, since they still made mistakes despite the tutors' notes and reminders. For example, students such as M2 and M3<sup>7</sup> made quite a few referencing mistakes although the tutor provided samples of correct referencing.

The EM module convener/lecturer mentioned that he was always available and encouraged the students to contact him by email, by knocking at the door, or at the end of a lecture (transst5:3). According to him,

Towards the time when they are completing their assignments...you get quite a lot of contacts. Quite a lot of people knocking on the door, saying we are thinking about doing this, are we on the right line; we don't quite understand this concept, can you explain it again....Some groups came around to see me two or three times; other groups didn't come to see me at all. They are told I'm available, and if they want to talk to me, I'll talk to them. Some emailed

---

<sup>7</sup> A student in the MSc. in Management programme that I interviewed but whose case was not reported in this thesis.

quite frequently. And they asked things like where can I find out about this, and then I will give them some tips. But you know, when you are at master's level, you have to be able to research, and part of the purpose of the project is to get them to do that (trans5:4, 6).

Although the lecturer, whose data is quoted above, did not offer very detailed written guidelines compared to the LM module tutor (see appendix 21), he had discussed the requirements in class, and he had encouraged students to contact him if they had any queries. M2's group asked one of the lecturers for further references, but the problem was they could not get hold of some of the materials she recommended and the ones they did get were not very relevant to their topic (trans2:1). M3's group for the EM module, who chose the same topic as M1's group did, consulted the lecturer quite actively because they were very confused about what the lecturer would expect them to do, and got a lot of advice from the lecturer, and this appeared to have been important for M3's group getting a much better result (68) than M1's group (56) (trans5/2:2). M1 did not ask for tutor advice for the two assignments I have discussed here. One of his course mates asked the tutor about the LM assignment, but the answer from the tutor did not seem to help, according to M1 (trans4:1), which may have made M1 think it was not worthwhile consulting the tutor again. For the EM group project report, M1's group did not seem to worry about the understanding of the task, which may partly explain why they did not contact the tutor. Another possible reason may be most group members were busily engaged with another group project which required much more time, so that they might not have time to think over the EM group report. Whatever the reason might be, E2 and M3's cases seem to indicate that active communication with the tutors often saved the students time and trouble in working out things that they may have difficulty with.

### ***8.3.2.2 Conflicts and Contradictions between 'Subject' and 'Community'***

#### ***8.3.2.2.1 Competition and Conflicts between the Students***

The MSc. in Management programme had a student population of over one hundred.

According to the students' reports, there was great competition among the students for the limited library resources available. Although they bought course books for most courses, they still needed other references for most assignments. M1 and M2 both reported that they had difficulty getting hold of books at some points. If they started their assignments late, there would not be any book left in the library; if they borrowed books much earlier than they actually started working on the assignment, by the time they needed to start reading, the books were very likely to be recalled (transc6:1). M1 mentioned the experience of doing the last assignment before the dissertation, where he was very successful in getting the books he needed. What he did was during the 20-minute break of the session when the tutor announced the assignment requirements, he rushed to the library immediately in order to get the books before they were all gone. And to his surprise, there were already quite a few course mates there, who must have thought the same way as he did (transc7:7), which seemed to indicate that many students had already realized the great competition among their course mates for the limited resources and were trying to seek solutions to that.

The conflicts between the students that I am focusing on in the following mainly arose during the course of doing various group projects. First of all, group members might have a sense of responsibility that varied to a great extent from each other. As a result, some students often failed to turn up in meetings or to finish their share of work in time. For instance, one of M1's group mates often cancelled the meetings even though it was himself who suggested the meeting time (transc6:5, 10); another group mate of his often pretended that he was not informed of the meeting schedule because his phone was not working, or his computer system was down (transc6:10); some students simply ignored email messages from other group members. All of this made meetings and discussions difficult and delayed the progress of the work. Sometimes,

students neglected his/her group duties because of personal reasons. For instance, one of M2's group mates needed to go to her home country for visa renewal, and therefore did not take any responsibility except writing her part of the report, which was done hastily after other group members urged her to hurry up (transd7:1-2). Another group mate, whose English was the best in M2's group, was responsible for combining their writings into one piece and checking the language. However, she also needed to fly home before the deadline arrived. Before she left, she gave M2 the whole report and told her the structure looked a bit broken, by which time it was too late to make changes (transd7:2). Time management was another big problem that both M1 and M2 encountered during group work. In many cases, it was not that they could not finish their share of work, but that other group mates failed to finish theirs in time (see 8.2.2.1 above). Another aspect reported by M1 was the doubt that some western students held for Chinese students' language ability. As a result, they insisted upon taking the responsibility of combining different pieces into a whole, or of writing some important parts (transc5:1). One of M1's group mate even insisted upon changing the sentences in a way that changed the meaning of them despite others' objection (transc5:3). There were also occasions when a group member refused to comply with group decision and stuck to his/her own understanding, which, according to the tutor's feedback, turned out to be wrong (transc5:1-3).

Such conflicts might not necessarily affect each individual group member very much in reading and writing his/her part of the group work, but they nevertheless made a great difference in the group members' experience of doing group work and, it seems reasonable to assume, may have made a difference in the final results of the group work.

### ***8.3.2.2 Conflicts and Contradictions between Students and Tutors***

Conflicts and contradictions between the students and tutors sometimes resulted

from their different understandings of the purpose of teaching and learning the courses and the doing of assignments; in some cases, the contradictions were even rooted in the design of the whole MSc. programme.

Take the LM module as an example. Both M1 and M2 complained that the course was uninteresting and did not make much sense because they could not think of the connections between this course and their real life (transc2:9-10, 14, transd2:5, also see 5.3.3.2 above). It was not that the sentences in the textbook or the tutor's lectures were difficult to understand, but that they could not see the overall points that the texts and lectures were trying to make, i.e. what they meant to them in their future lives and careers. As M2 said "I understood what she said in class, but when the lecture finished, I had no idea what it was about. ... Maybe it was too theoretical and not practical enough which made you feel unmotivated to study it" (transd2:5). M1 also said that "attending the lectures made no difference (in my understanding of the contents of this course). ... I read the chapters very carefully, sentence by sentence, and I understood each sentence. But still, at the end I felt as if I had not read anything" (transc2:9, my interpolation). As a result, M2 seldom read the textbook before attending the lectures (transd1:12); M1 did read before each lecture and did find reading helped him understand the lectures, but still he felt the course difficult (transc2:9). Both of them seemed to spend more time on more practical courses, such as 'Finance', 'Project Management', and 'Operations Management'. The module LM convener/lecturer was also aware of the students' complaint about the difficulty of this course and suggested that the students study the texts more and ask her in class or ask the seminar leaders in seminars anything that they could not understand (transc2:9). The lecturer commented on this in one of the interviews as follows:

I find the students kept on saying this is too difficult. They say it's difficult because they try to read it once. ... Yes, it's too difficult because you never study this. Like I said, I went to China and was asked to do something I didn't know. It would be very difficult. That doesn't mean I

couldn't try hard, listen to people, and try to read whatever it is that I need to read three thousand times if you need it. ... Every time I said, look you have only read it once, and probably at first glance you would understand this bit. Then you read another time, you understand this bit, and you read another time, you understand this bit. ... I told them to talk to others, discuss it with your colleagues. Discuss it together. Take the lecture on the one hand, all the notes you have from the lectures; take the chapter on the other hand. Compare, bring them together. That's what learning is about. (transst4/2:5-6).

There were also seminars for the LM module, where, according to one of the seminar leaders,

They were supposing an environment in which they had a particular task to carry out. What they would have done if they were in that particular situation, by being in a group to organize those activities in order to complete the work. ... The exercise was a way to stimulate discussion ... (and was) also very imbedded to the lecture, what the lecturer said during the lecture" (transst6:1-2, my interpolation).

It seemed that the seminars were designed to help students think about the topics discussed in the lectures in a more concrete and real life way by situating them in the case studies. The seminar leader also said that some students were interested in what they were doing and were participating actively (transst6:2). However, M2 did not think the seminars useful, as she did not think the exercises in the seminars had much to do with the lectures. For example, she could not put the teamwork theories taught in the lecture into practice when she was doing real teamwork (transd1:12). However, according to the lecturer, M2's problem was likely due to her lack of engagement with the theories and concepts they studied, which she also found in many students' writings (transst4/2:8). The lecturer called this:

'The syndrome of the man in the street', which basically means if for example I have this question of teamwork, I can ask a man walking down there, 'can you write me five pages on teamwork?'. And he will write five pages on teamwork because he's got plenty of experience of working in team; he probably read a few things in teamwork for example in terms of safety regulations; he might have listened to many things on TV or radio, read newspapers, where there's plenty of stuff on teamwork... and he wrote five pages. Now many students would not do the reading, and write in the same way that man would be writing—common sense. ... So what's the point of coming to a university if you don't engage with ideas and theories and issues and problems that we are trying to unpack. If you have to think the same way you thought before, then there's no point of coming here. But there's the laziness. There are people who do not want to engage, and that really bothered me. (transst4/2:8)

It seems that the students were complaining about the lack of connection between what was taught in the LM module and their real life situations; whereas the tutors were saying that it was because the students did not read enough and did not engage with the texts and ideas sufficiently. The students may have preferred other courses that they

found more practical than this one, so that they spent more time on those courses. In fact their timetable was so full that they simply ended up with no time or very little time for this module. Therefore, the tutors were probably right in that if the students spent more time on it, they would not find it as difficult and would learn something useful from it, but they could of course not do so, due to a general shortage of time occasioned by their study load. As M2 confessed later, when she was preparing for the LM module exam<sup>8</sup>, she found the textbook quite interesting and not as difficult as she used to think if she could really carefully and attentively engage with it (transd8:10). However, she did not enjoy the lectures<sup>9</sup> and did not have a good experience of doing the essay for this course, because at that time, she was more occupied with other courses and did not have the time to find out more about this course. This may largely be due to the design of the MSc. programme, which was a very intense and inclusive programme that touched upon almost every aspect of management. According to the LM module lecturer,

The message that has been given is you need to make things as simple as possible, because of the diversity of the students, because they are new to management. And that's why I have chosen only one textbook.' (transst4:2). ... I have been asked to teach that way. Fair enough, I can do that if that's what people want in this university. ... This is the chapter. Study for me a chapter each week. I can give you a lecture on that. I can try to explain these things the best way I can. I can give you all the examples. ... That's not learning to me. (transst4/2:5).

Students, including M1, M2 and some of the course mates that they talked to, felt they did not learn much from the LM module. And it seemed there was something beyond the power of both the tutor and the students that caused the conflicts between them in the current situation. Or in other words, there was conflict between the tutors and students on the one hand, and the MSc. programme AS as a whole on the other hand. To ease this conflict, this particular lecturer was thinking about change, as she said:

This is a big problem for me, ... in terms of my intellectual honesty as a teacher and as a learner. I find this complicated and contradictory, because there are so many different demands. I think one has to be true to one's own sense of ethical and political commitment, and true to the students. So the situation we are in is asking us to be in a way that I do not

---

<sup>8</sup> The LM module exam was scheduled in April, whereas the course was conducted in the first term.

<sup>9</sup> The lecture was scheduled from 5pm to 7pm, which according to M2 was the time of the day when she felt most tired and sleepy.



agree with and I find difficult to find a way that can be true to what I want, what the university wants, what the students want. I'm struggling with that. Introduce ways of changing the assessment ... perhaps that's a way ... of trying to deal and to negotiate this contradiction. ... I want to give good marks to students who show a level of commitment and a level of engagement, and personal elaboration of what we're trying to do. So I have to find a way of tapping into that (transst4/2:4).

M1 and M2 seemed to be not only unable to learn the module as the lecturer expected, but also unable to produce the essay in a way that properly met the tutors' expectations. Take M2 as an example. Her marker criticized her way of using the literature as 'patch work', which meant

putting together sentences from this author, sentences from another author, sentences from another author, and just putting them together. ... There's no flow. It doesn't work as an essay because it doesn't have a clear argumentation. And it doesn't have a rigorous set of arguments that are supported by the literature, rather than put the literature as some kind of authoritative spokesperson that tells us the truth (transst4/2:7).

The marker further commented on M2's essay,

This is putting together bits and pieces without really explaining anything. ... I'm not asking you to give your opinion. I'm asking you to argue for something. You have to support your opinion. She used this source, which is great source. But it's one of the other things. We haven't even talked about his work in the textbook. ... We have studied a chapter where we have references of so many different authors and so many different ideas. We talked about culture in so many different ways. ... Why is it that she didn't engage with that? (transst4/2:10).

It seemed that M2 did not use the literature in a way that the tutor expected – to form arguments. Moreover, she did not use the references the tutor expected the students to, i.e. the references that appeared in the textbook and that were discussed in the lectures.

The marker also criticized M2 for using Internet sources because in the tutor's opinion,

The fact that you use someone who wrote something and posted it on the Internet doesn't make it an authoritative reference to use, unless it's obviously recognized and relevant e-journal or university website or company website. ... Like 'my cousin said leadership is important'. Why should I believe in your cousin? Why should your cousin's opinion be important to our understanding of leadership? (transst4/2:7).

M1's marker was also not very satisfied with his way of using the literature in the essay, by commenting that

He was just getting some information from the course and then sticking them all here, without actually thinking through and carefully understanding what the differences are between these arguments that are reported... It is obviously fine because the student seems to know what he is talking about. But to have something better, to go higher, then maybe we need to find something else. ... What I'm saying is articulation of topics have to be proved. The articulation means linking them logically, and sometimes articulating or explaining why one statement can have a limit and why it is that you move to another one which in your view can be better to explore the thing that you want to say. In here, it's a 'copy and paste' exercise. (transst6:4).

The marker's criticism of M1's essay was similar to M2's, in that both were seen to

be a collection of statements or opinions from others without proper explanation and interpretation of the reasons for using them in their essays. The aspects that M1 and M2 did not do well in their essays had already been pointed out to them by the tutors in different ways. For instance, in the course booklet (appendix 17), the students can find 'essay tips' which emphasized the importance of providing 'convincing, clear and rigorous arguments' in the essays. The central role of the main textbook was repeated over so often by the lecturer (transst4:2, transc3:3, transd2:7) and was also written down in the module outline (appendix 16). M2 was found to make referencing mistakes in her essay, whereas there was a clear guide for correct referencing in the assessment details (appendix 17). It seemed that the students made mistakes even if they were reminded to avoid them, which might be because they were too short of time to notice or they did not realize the importance of such information, and hence ignored it.

Similar things happened while M1 and M2 were doing the assignment for the EM module. According to one of the lecturers, "if I was to reflect back on this group of projects and the projects we've looked at year on year, they tend to be very well researched. Where the students are found to fall down is to not put enough economics into it" (transst5/2:1). M1's group was criticized particularly for this problem that the lecturer found common among the students over the years. The lecturer expected M1's group to talk about the type of industry under focus, i.e. were there only a few competitors or lots of competitors, and then to predict what kind of conduct the firms would undertake, i.e. were they competing or were they colluding; then to work out what the performance was in terms of economics—what prices the consumers got charged; how much choice they had in terms of the type of products available on the market; how much profit the firm made; whether the firm used the profit to innovate and create new products or simply used it to pay off shareholders (transst5/2:2-3). The

report that M1's group produced was "very descriptive", "missed out the discussion of performance", and "missed out discussion of certain issues", according to the tutor (transst5/2:2-3). He further remarked that,

If they are studying twenty hours of economics lectures, then we'd expect to see more. ... It's (the description) interesting; it's fine; it's good. But it's not going to get you a lot of marks. I could have asked a student doing business studies to write the report. The point is they are doing an economics course. They needed more economics in it. I don't think they engaged with it properly. (transst5/2:3, my interpolation).

M2's marker also criticized M2's group for not offering "exactly the kind of analysis" (transst7:5) that she expected. According to her,

(The report) didn't offer much of empirical studies ... in terms of ... some sort of table to show what happened to the level of investment within the volume of trade between the western and the less developed economies; so show some sort of data; show some idea what is happening in terms of volume of trade, in terms of volume of investment. If you talk about the tariff, the reduction of tariff, how that has been affected in terms of manufacturing...' (transst7:4, my interpolation).

M2's marker further pointed out that the reason why she wanted to see the students using empirical data was because it also showed that they can do the kind of "analytical type of analysis" with the data (transst7:3). Judging by the marker's comment quoted above, M2's group failed to present the type of analysis that the marker expected.

In fact, what the tutors expected from the group reports was stated quite clearly in the assignment requirements and topics (see appendix 21). And one of the lecturers also talked about the assignment in class (transst5/2:1). But M1 and M2's groups nevertheless seemed to miss some main points in the requirements, such as the essential requirement of providing economic analysis for the economics assignment. They may not have examined the requirements carefully enough before doing the assignment due to the time pressure, or due to their lack of experience in producing this kind of writing and using readings in this way; or it might also be due to the complexity of group work that was discussed in 8.3.2.2.1 above.

The analysis above indicates that time constraints might be one reason for the students' lack of attention to various features of the execution of the assignments as already mentioned, and it was quite understandable that when the students were

working day and night trying to meet all sorts of deadlines, they neglected one thing or another unconsciously or they simply did not have time to attend to them (see 8.2.1, 8.2.2 above for details), or they even left the most fundamental basics out, such as not putting economic analysis into the assignment for the economics course.

To sum up, the discussion in this section as a whole shows that the conflicts between the students and tutors lay firstly in the fact that the students and tutors had different understanding on the purpose of learning some courses and the purpose of doing reading and writing tasks, as was evident according to the LM module lecturer (trans4/2:6). Secondly, the conflicts lay in that the students sometimes did not use the right sources for their literature as the tutors expected, or in other words, the students' understanding of the legitimate reference sources seemed to be different from that of the tutors', as tutors for both the LM and EM modules criticized the use by the students of Internet sources (trans4/2:7, trans5/2:4). Thirdly, conflicts lay in the students' and tutors' different understanding of the way in which the literature should be used in the writing and their different understandings of other writing requirements in general, as was discussed earlier in this section. The discussion here also shows that students' academic reading practices for writing assignments were related to various aspects of students' studies (e.g. students' purposes of learning the courses; their attitudes towards the lectures, seminars, and reading tasks, and so on), and therefore could not be so fully understood if studied from a narrower perspective. The pedagogical implications of the discussion in this section will appear in the final chapter (see 9.4.3 below).

In the next section, I will discuss the relationship between the 'subject' and 'rule', as the discussion above seems to indicate that some of the conflicts and contradictions between the 'subject' and 'community' have resulted from the contradictions between the 'subject' and 'rule', or the discontinuity between the 'rule' in the subject's past AS

and the current one.

### 8.3.3 'Subject' vs. 'Rule'

The relationship between the 'subject' and 'rule' that I will talk about here is only what is involved in the process of reading for writing assignments rather than what is involved in the course of their masters' programme as a whole.

Both M1 and M2, as English majors in Chinese universities, had a lot of experience of writing English essays during their undergraduate years. However, both of them were criticized for the way they constructed their essays, such as putting statements of different authors together without interpretation or links between them (see 8.3.2.2.2 above). M2 had noticed some difference in the essay writing in the UK after she took the university study skills summer course, as she once mentioned that "it was different in China—we simply copied from one source or another and put them together. It won't do here. One really needs to understand, to interpret, and to paraphrase" (transd2:4). But what M2 had already realized still could not help her write in a satisfactory way. M2 thought that she just needed to write down her understanding of what she read rather than make her own arguments (transd8:1). Her essay for the LM module was not the only one with this problem. M1's understanding of a literature review was also problematic. He had thought that, in a literature review, he should only list things said by others without stating his own views (transc6:12). He did not realize that his view of a literature review was problematic until the end of the second term. He did not have much doubt about his own understanding of it during the first two terms. M2's understanding of what empirical studies for an economics assignment involved was also different from her marker's. M2 thought she provided a lot of cases, at least in her part of the report (transd7:1), whereas the marker thought they did not offer much empirical data, neither did they analyze the empirical data in the expected way, such as

by looking at the volume of trade, volume of investment, etc. (transst7:4-5). In addition, the 'rule' about plagiarism and referencing also seemed very different from that in China, which caused great concern for some students including M2 (see 8.3.1.2 above).

The LM module convenor/lecturer pointed out that one of the basics of essay writing is to argue for and against, to have some kind of "analytical tension" (transst4/2:2); the lecturers of the EM module would like to see economic analysis in the students' reports. Obviously however, some students failed to understand the tutors' expectations. One of the tutors remarked that

It's very difficult for them to understand the genre in itself. That is problematic because these students are not used to writing academic essays. ... most of them, they are educated in a different way, in a different tradition. And then they come here for a year, and they are asked to respect canons and criteria that they don't really know about, they haven't been trained into. That's kind of crazy, as if I come to China and you would ask me to be there and respect all the way. You would invite me for a meal. I've got there and I would have made a mess of it because probably the way the formal meal in China works might have the rituals, canons, procedures, etc. that are very difficult to understand. You can lay them out like I do, explaining you should do this way, the other way, the other way. You try to explain to people how and what they are supposed to do. And you also write it down so that they can go home and look at it for themselves. But you are not going to learn how to behave properly at a formal dinner in China just because you tell me how to do that (sic). You have to tell me quite a lot of times. I think that's kind of metaphor to explain to you what I think about all the Chinese students, but not only Chinese, also from other countries, try to do an essay within the English academic system. (transst4/2:2)

This tutor's comment in the above part of the data seems to explain quite well the reason why Chinese students had difficulty understanding the 'rule' of the academic system in the UK, which may, in turn, explain why they had difficulty in understanding the tutors' expectations. And she seemed to suggest that it was the tutors' responsibility to explain the 'rule' to the students as often as possible, which is also related to the 'division of labour' I will discuss in the next section.

### 8.3.4 'Subject' vs. 'Division of Labour'

As postgraduate students, M1, M2 and their course mates, as well as E1, E2 and their course mates, were, from their tutors' point of view, supposed to already know how to handle central aspects of studying at university, such as reading, writing essays, searching for literature (transst4/2:2, 6, transst5/2:4, transst5:6). Moreover, the tutors

explained to the students, more than once and in various forms, the reading and writing requirements, their expectations, the aspects to pay special attention to, and so on. However, the students still seemed to fall short of the expectations in one aspect or another. One tutor's comment quoted in the end of the preceding section has shown the difficulty on the part of Chinese students in adjusting to the English academic system within a short time. The four cases discussed here all seemed to indicate that the results of their academic work did not necessarily improve as time went by. They faced different challenges at different points because the assignments they were asked to do were not of the same nature. Even though some tasks were similar, they may not necessarily learn much from the past experience (e.g. E1 and E2's experiences of writing a critical review), or they may make mistakes in different aspects (e.g. M2 was criticized for not offering arguments earlier on. When she did try to argue for something in a later assignment, she was criticized for not offering much of the academic theories and concepts. As a result, she did not get satisfactory marks for several assignments over the first two terms, transd8:1).

## 8.4 Conclusion

This chapter has presented a detailed picture of the two subjects' reading practices during the course of writing two assignments in the Lancaster University MSc. in Management programme. Although from another subject area and doing assignments with different requirements, M1 and M2's processes of reading for the purpose of writing academic assignments also consisted of similar stages as E1 and E2's cases (i.e. understanding the task and choosing the topic, identifying and searching readings, reading and integrating reading into writing). Also similarly, whether they could manage well the tasks in each stage was closely related to the interactions between the subjects' past education and literacy experiences, their usual attitudes towards learning

and reading, and the current contexts (including the reading and writing requirements for different modules and courses, the academic conventions and norms of the two masters' programmes, the relationships between the students and tutors, the availability of the tutors' support, and so on). Apart from the individual characteristics, the differences in M1 and M2's academic reading experiences, in comparison to E1 and E2, mainly seemed to result firstly from the time pressure due to the larger number of compulsory and elective courses and the combined means of assessment (i.e. most modules were assessed by a combination of individual course work, group project and exam). Secondly, the assessed group projects imposed on the students a more complex situation than just doing individual work for assessment. Besides doing his/her portion of the task, individuals could not easily control or even influence other group members' performance, and therefore had limited control over their experiences of doing the group projects and over the final results.

By using the NLS/AT framework established in Chapter 2, this chapter, once again, has demonstrated that the process during which the 'object' of the academic reading activities was constructed remained similar among all four subjects for all four assignments examined in this study. The activity theory (AT) analytical framework also helped to reveal the differences inherent in the two masters' programmes and between the four subjects, which all contributed to the different academic reading experiences of the four subjects. M1 and M2's experiences of doing the two assignments analysed in this chapter seemed to confirm many findings in Chapters 6 and 7 and also to reveal certain different features of students' reading practices due to the difference in subject areas, assessment requirements, programme structure, tutor-student and student-student relationships. The analysis in this chapter has thus once again demonstrated what is to be gained by viewing reading as not simply a matter of technical skills, but, instead, also



in terms of the situation in which it occurs and the life experiences and other personal characteristics of the reader.

The analyses in this and Chapters 4 – 7, as already indicated (*passim*), also obviously give rise to a number of potential implications for pedagogical practice. Among other matters, Chapter 9 will therefore concern itself with this aspect of the research, as well as the theoretical insights gained from this study.

Chapter Nine: Conclusions.....	313
9.1 Introduction .....	313
9.2 Summary.....	313
9.3 Theoretical Insights .....	317
9.4 Pedagogical Implications.....	320
9.4.1 Implications for ELT in China.....	320
9.4.2 Implications for EAP Programmes.....	321
9.4.3 Implications for Subject Area Teaching in UK Higher Education .....	324
9.4.3.1 The Need for more Harmonious Tutor-Student Relationships.....	324
9.4.3.1.1 Understanding the Differences between the Two Education Systems .....	325
9.4.3.1.2 Understanding the Language Barrier.....	327
9.4.3.2 An Appropriate Level of Support.....	329
9.4.3.3 Programme Design .....	331
9.4.3.3.1 At the Intra-programme Level .....	332
9.4.3.3.2 At the Inter-programme Level .....	334
9.5 Limitations of the Study and Directions for Further Research .....	336
9.6 Final Remarks.....	337

## Chapter Nine: Conclusions

### 9.1 Introduction

In this final chapter, I will first summarize the ground covered by the thesis as a whole; I will then attempt to identify the overall potential implications of the study for ELT in non-English speaking countries, for EAP and for subject area teaching in UK higher education, and for the application of the NLS and AT frameworks in studies of academic reading (especially involving the L2); finally I will discuss the limitations of the study and suggest possible directions for future investigations in the area of L2 academic reading.

### 9.2 Summary

Chapter 1 introduced the background to undertaking the study, and briefly explained its purposes, the reasons for the choice of topic (i.e. academic reading) and the overall nature of the research approach (i.e. one which looks at academic reading from a contextualized literacy practices perspective rather than in terms of technical skills). Chapter 2 discussed the basic tenets of NLS and AT as methods of viewing academic literacy in such terms, and the appropriateness and advantages of combining them together in the study, thus establishing its theoretical underpinning and analytical

framework. The methodology chapter that followed discussed the ontology and epistemology of the study, the specific procedures for its design, execution, and analysis of the data yielded. It also presented the research questions and the methods of data collection in relation to each research question.

Chapters 4 to 8 were concerned with attempting to answer each of the main research questions via the presentation and analysis of various aspects of the data resulting from the research design. Chapter 4 focused on RQ 1 (i.e. *What were the main reading practices of the subjects—E1, E2, M1 and M2—before they came to the UK?*) and RQ 2 (i.e. *What aspects in the context (in terms of the activity system model) have played what role in the shaping of the subjects' reading practices prior to their arrival in the UK?*). In order to answer RQ 1, the four subjects' educational and literacy experiences prior to their arrival at the UK were explored and presented in the form of narratives. On the basis of the subjects' experiences, the AS of the Chinese education system was constructed to investigate the factors contributing to their reading experiences in China, as well as to serve as a reference point for the analysis of the subjects' reading practices in the UK higher education in Chapters 6-8. The analysis of the subjects' experiences of learning and reading in Chinese and English in Chapter 4 showed that, in general, the students' initial interest in reading in the mother tongue was most likely developed at a young age under the influence of their caretakers (i.e. parents, grandparents, relatives, etc.), whereas the influence of peer groups and the desire to be included in and recognized by peer groups also encouraged reading and was even of potential help to them in developing a lasting interest in reading (e.g. in M1's case). Reading in English was mostly driven by instrumental motivation (Gardner & MacIntyre, 1991; Spolsky, 1969, , 2000; Walsleben, 1988) and was done for the purpose of improving their level of English. Reading in Chinese and English that was related to school work seemed largely

to serve the purpose of preparing for various exams. Reading done that was irrelevant to school work varied from subject to subject depending on their personal interest in reading, though, generally speaking, none of them had much time for reading for pleasure during their years at secondary school due to the pressure of the nation-wide College Entrance Exams. The analysis in Chapter 4 also showed that each subject established his/her unique attitudes toward reading and learning over the years of their primary and secondary education, which, in turn, had a strong influence on their educational and literacy experiences at university in China.

Chapter 5 explored the context of the subjects' lives and academic studies at Lancaster University and their literacy practices in general after their arrival in the UK, with a view to answering RQ 3 (*What are the main kinds of academic reading practices which the students experience in a UK university setting?*) and RQ 4 (*What are the features of the activity system of a master's programme in a UK university in comparison with and in contrast to the activity system that the subjects used to belong to in China?*). In doing so, this chapter was structured in a similar way to Chapter 4, i.e. it comprised narratives of the subjects' literacy experiences, but this time in their UK context, followed by an analysis of the two masters' programmes—the MA in Education and the MSc. in Management—from an AT perspective. The analysis indicated that the majority of the reading done by the subjects at Lancaster University focused on academic readings in English, which differed from the reading they did at universities in China either in terms of the subject area of the reading materials and/or in terms of the language used in the reading materials. It also seemed evident from the data that the subjects' attitudes towards reading and learning and their individual self-perceptions as students and persons remained unchanged and played crucial roles in shaping their academic literacy practices at Lancaster University. For example, E1

seldom invested her efforts in subjects that did not interest her and she did not like reading in English very much. As a result, she hardly did any pre-reading tasks before attending the lectures in which she was not interested during her master's studies. On the other hand, M1, who always tried to fulfil tutors' reading requirements no matter whether he had interest in a subject or not, continued to do so in Lancaster University. In addition, the data also showed that the subjects' recent educational experiences at universities in China and their working experiences influenced their purposes in undertaking their masters' studies, and, in turn, also affected their literacy practices. For instance, E2 and M2 both preferred to learn some practical knowledge, thus were more willing to spent time reading for more practically-oriented modules. The analysis of the AS of the masters' programmes at Lancaster University also revealed contradictions and discontinuity between the AS of the Chinese education system and the AS of the Lancaster University masters' programmes (e.g. the differences between the two systems concerning the 'mediating artefacts', the 'division of labour' between students and tutors, the composition of 'community', etc.), thus preparing the ground for the discussion of the shaping of the subjects' reading experiences while writing academic assignments, which was the focus of the data reviewed in Chapters 6-8.

Chapters 6, 7 and 8 focused on the two most central RQs of this research—RQ 5 (*What literacy experiences did the subjects actually have while reading for writing assignments within the context of their current activity systems?*) and RQ 6 (*What factors appear to have led to the subjects having such experiences?*). Chapter 6 dealt with E1 and E2's experiences of writing the assignment for the IER module; Chapter 7 was concerning E1 and E2's experiences of doing the assignment for the TLA module; Chapter 8 focused on M1 and M2's experiences of doing the assignments for the LM and the EM modules. In overall terms, the analyses in the three chapters indicated that

there were certain stages that all subjects went through during the process of reading for the purpose of writing both academic assignments. However, their experiences varied in many ways. Such different experiences not only resulted from the differences between the two masters' programmes and different reading and writing requirements, but also from the subjects' different attitudes towards reading and learning, from their different purposes of pursuing their masters' degrees, and from their interactions with the other components in the AS of their masters' programmes. The analyses also indicated that the interactions and contradictions between the 'subject' component and the 'community' component played active and crucial roles in shaping the four subjects' experiences of reading for the purpose of writing assignments. These contradictions seemed to result partly from the contradictions between the 'subject' and the 'rule' and the 'division of labour', which, in turn, mostly resulted from the discontinuity between the AS of the Lancaster University masters' programmes and the AS of the Chinese education system.

Having summarised the foregoing parts of the thesis, I turn next to the main theoretical and pedagogical implications which I believe the study yields.

### **9.3 Theoretical Insights**

In Chapter 2, after reviewing the main arguments of both groups of theories, a combined NLS and AT framework was established for the investigation. The application of this framework in the ensuing study seems to have shown that its strength lay mainly in the way it made it possible to investigate the whole process surrounding the activities (i.e. in this study, a series of literacy events relevant to academic reading activities for the purpose of writing academic assignments) within its context (i.e. the 'mediating artefacts', 'rule', 'division of labour' and 'community' elements) and explore the interacting factors that shape the process of activities and their outcome. In

other words, this framework appears to enable the researcher i) to unfold the dynamics during the course of the subjects' engagement in literacy activities, and ii) to reveal the interactions between the subjects in question and the context of their literacy practices that shape or influence the process of their engagement with literacy and their experiences of such engagement.

This study has also shown the possibility and the appropriateness of integrating the NLS and AT frameworks for literacy studies. As was discussed in 2.4.1 above, both NLS and AT are partly rooted in the Vygotskian school of cultural-historical psychology, which means that they have a number of common theoretical elements, creating a *prime facie* case for their possible integration. From the discussion of the framework in Chapter 2 and the data analyses in Chapters 6 to 8, it seemed quite evident that the central concepts of NLS approach are compatible with the components of the AS model. First of all, the starting point of many investigations in NLS - the literacy event - constituted the core unit of analysis of the academic reading activity under focus in this study. In other words, the exploration of the process of the construction of the 'object' for the academic reading activity for the purpose of writing assignments was carried out by examining a series of academic literacy events with which the subjects were engaged in order to read for writing their assignments. In this way, once a researcher has decided on what the focal literacy activity to be studied is, then the scope of the literacy events that the researcher needs to look at for the particular study also becomes clear accordingly.

Secondly, as the study has also shown, two important concepts in the NLS tradition - personal literacy history and emotional aspect (e.g. ruling passions) - can be integrated into the 'subject' component in the AS. Thus, in the discussion of the 'subject', the personal literacy history and the emotional aspect ('ruling passions') for literacy of the

person(s) in question were explored as well as his/her/their past educational and working experiences, in order to show how these factors functioned to shape their literacy practices.

Thirdly, the context element in the NLS framework has been specified via the AS model to include the ‘mediating artefacts’, ‘community’, ‘rule’ and ‘division of labour’. In this way, the combined NLS and AT framework enables the researcher to investigate the essential roles which context plays in people’s literacy events and practices in a more systematic way.

Fourthly, and related to the previous point, the AS model helps the researcher capture the interactions and contradictions between the ‘subject’ and the context (i.e. the four components in the AS mentioned in the preceding paragraph) at different stages of the whole process of the activity under investigation. In other words, the combined NLS and AT framework is helpful for revealing the dynamics of literacy activities, which is crucial to an explanation of the shaping of the subjects’ literacy experiences.

Fifthly, it is also possible to list the features of the current AS and any past one (or any two parallel ones) in the same diagram (see figure 5.1 in Chapter 5), thus making comparisons and contrasts between two systems easier and more convenient. Therefore, by combining NLS and AT, literacy studies across time and across contexts become more manageable.

Last but not least, the analysis of the process of constructing the ‘object’ of the academic reading activity as one of the two major parts of the data analysis (the other part being the exploration of the interactions and contradictions between the pairs of the components and between the past and current activity systems) has indicated that although the assignment requirements were the same for all students in the same master’s programme, each individual subject was undertaking different academic



reading activities as each of them was working at a different ‘object’ at different stages in the process of their activity. Consequently, their experiences of reading and their final results for the assignments also differed from each other to various extents. In other words, even if the students were seemingly working at the same tasks, they were working towards different ‘objects’ due to the interacting factors that this thesis has attempted to reveal, and hence they were engaged with different activities and thus their experiences of undertaking the activities varied. How to make the subjects’ consequent experiences of academic reading more rewarding and smoother than the data have shown was the case will be one of the focuses of the following section.

## **9.4 Pedagogical Implications**

In this section, I will discuss the overall pedagogical implications that I believe may be drawn from the study for i) ELT in China, ii) EAP programmes, and iii) subject area teaching and the design of the masters’ programmes in UK higher education.

### **9.4.1 Implications for ELT in China**

The analysis of the four subjects’ learning of English in the AS of the Chinese education system seems to show that their English language education was so exam-oriented, at the secondary level in particular, that the students tended to equate learning English primarily with doing exam preparation exercises (see e.g. 4.3.3.2, 4.5.2 above). Even at the tertiary level, E2 and M2 still seemed to associate learning English with preparing for exams. It seemed that the exam-oriented English language education over the years in secondary schools had influenced the students’ conception of language learning to be of this kind. It thus seems quite understandable that many Chinese students tend to see passing exams as their main ‘object’ of learning English. Even though such an ‘object’ may not be consciously perceived by the students

themselves, as the subjects in this study rarely mentioned that explicitly, their accounts of how they learned English seemed to have revealed this as the primary “hidden” ‘object’. The comparison and contrast between the AS of the Chinese education system and the AS of the Lancaster masters’ programmes during the analysis of the four subjects’ reading for writing assignments (see e.g. 6.2.2, 6.3.2, 6.4.2.2, 7.3.2.3.2, 7.3.2.4, 8.3.2.2.2, 8.3.3) seemed to indicate that the exam-oriented English language education they had had in China often put them in an disadvantageous position when they were faced with the academic reading and writing requirements for assessment purposes (and the listening and speaking requirements while attending lectures and seminars), as all these areas required a much more communicative, real-life use of English.

Therefore, in addition to helping students with the exams they need to pass, it would seem desirable for English language education in China to also take into account the actual uses of the language in students’ later life and prepare them for those real-life occasions where English is needed (e.g. study abroad, work in multinational companies). In other words, rather than seeing a satisfactory result in one of the main state English language examinations as both a necessary and sufficient qualification for use of English in overseas study settings such as the UK, greater consideration might be given to the development of additional or alternative programmes of study, better suited to preparing students for a less examination-oriented approach to the subject and a more real-life communication-oriented one instead. In addition, ethnographic research aiming to reveal the picture of the uses of the English language in the students’ future life and work, such as the current study, might be conducted before such curricula are developed.

#### **9.4.2 Implications for EAP Programmes**

In addition to their English proficiency in general, another factor closely related to

the subjects' academic reading experiences in Lancaster University was their competence in English for Academic Purposes (EAP), as the analysis has shown that many of the conflicts between the 'subject' (the Chinese students in question) and 'community' (members of staff) arose out of the conflicts between the 'subject' and 'rule' (academic conventions in particular) (see e.g. 6.2.2, 6.3.2, 7.3.2.3, 7.3.2.4, 8.3.2.2.2, 8.3.3). Even though three out of the four subjects attended the Lancaster University four-week summer 'Study Skills' programme before they started their masters' studies, and both masters' programmes offered academic 'study skills' course to overseas students in the first term (and a couple of sessions in the second term in the MSc. in Management programme), the subjects still experienced various important problems concerning their academic reading and writing tasks. For example, they made mistakes in referencing (see 6.3.2, 8.3.2.2.2, 8.3.3); they did not organize the essays properly (see 7.3.2.3.2, 8.2.1.3.1, 8.3.3); they did not know how to write critical reviews (see 7.3.2.3.1); they sometimes had difficulty interpreting the requirements of their writing tasks (see 6.3.1.2, 7.2.2, 8.2.1.1, 8.2.2.1).

The problems experienced by the subjects may have been caused by their inability to make links between the 'study skills' programmes and their reading and writing tasks. The reason could also be that the requirements made by the actual study tasks differed from each other and from those used in the study skills programmes so much so that the subjects could not manage to apply the general principles introduced in these programmes; it could also be that the academic conventions and norms applicable in their masters' programmes were so new and unfamiliar to the subjects that a few sessions of lectures and workshops were not sufficient for the subjects to learn; it could also be that because the 'study skills' programmes were not run at the same time as the subject area courses were, when the students came to do their readings and writing for

assessment purposes, they might have already forgotten what they learned from the 'study skills' programmes.

To overcome the problems mentioned above, it seems that an ideal and effective way of helping the subjects with the academic 'study skills' may be to integrate an academic support element together with each subject area module, so that the students are offered help specifically related to the readings and writings of the subject area course in question. Given the resources of academic staff, it may be difficult to provide such academic support courses for each single subject area module. However, it would appear advisable to try to provide such help at the very beginning of the masters' programmes (e.g. during the first term). The subjects' experiences in this study seemed to suggest that it may be less helpful to provide abstract and de-contextualized academic support programmes because newly arriving overseas students are unlikely to be able to properly gauge in what circumstances in their formal studies programmes the academic conventions and norms should be applied (see 7.3.2.3.1, 7.3.2.5, 8.3.3). Therefore, it is probably more desirable to offer concrete, specific and contextualized academic support programmes embedded within (preferably) each subject area module. There have already been such attempts in certain undergraduate programmes in Lancaster University - modules that integrate EAP elements and subject content appear to have already been conducted successfully in some undergraduate programmes at Lancaster University (e.g. in the BSc. Business Studies, BSc. Accounting and Finance, and BA. Media and Cultural Studies degree programmes). These EAP programmes have been embedded into the degree courses rather than run as extra and separate academic support programmes, thus providing students with the type of concrete and timely academic support that is closely tied to the particular subject content module into which the EAP elements were integrated. Feedback from the students taking these modules

seemed very positive and called for more such modules to be provided to a wider range of audience and in a wider range of degree programmes (Luxon & Peelo, 2006; Robinson, 2006; Taylor & Beekes, 2006).

### **9.4.3 Implications for Subject Area Teaching in UK Higher Education**

The analyses in Chapters 6-8 demonstrated that the primary factor shaping the subjects' experiences of academic reading for writing assignments was the interactions and conflicts between the subjects and the members of staff. One important cause for such conflicts may be the fact that Chinese students have rapidly grown in numbers in recent years in UK higher education, and thus, with such an influx, the nature of the audience being taught in many UK masters' programmes has changed quite significantly. As with any such change, it can be argued that it calls for a review of teaching-learning practices, in order to make sure they are still appropriate to the needs of the new audience. Likewise, Chinese students themselves have an important responsibility on their side to do their best to understand and adapt to what may be novel for them among the methods of teaching and learning which prevail in the study situation they are in. Both of these considerations should thus be seen as framing the suggestions that follow concerning the implications of this study for subject area teaching in UK higher education. These mainly involve the ways in which the relationships between students such as the four subjects and members of staff might be better handled, and how the design of masters' programmes might be adjusted to better accommodate and benefit such (and other overseas) students.

#### **9.4.3.1 *The Need for more Harmonious Tutor-Student Relationships***

The analyses in Chapters 6 to 8 indicated that the conflicts between the Chinese students and members of staff often arose from a mismatch in the expectations on the

part of the Chinese students and the members of staff, and a mismatch in the division of responsibilities on both parts (see e.g. the discussion in Chapter 7 on the understanding of critical review tasks in the MA in Education programme). Therefore, it seems important that both the students such as the subjects (and overseas students in general), on the one hand, and the members of staff on the other, become in some respects more aware of and more assiduous in taking up their respective responsibilities in the kind of masters' programmes which have been focused on. The data have indicated that this might occur with respect to aspects of this kind such as the following:

#### ***9.4.3.1.1 Understanding the Differences between the Two Education Systems***

Firstly, much of the mismatch between the Chinese students and the members of staff concerning their expectations of each other was due to the lack of mutual understanding of each others' education system (see e.g. 7.3.1.2, 7.3.2.3, 8.3.3). Therefore, it seems reasonable to propose in this respect that both students such as the subjects and members of staff in universities such as Lancaster should show greater awareness of the difference between the Chinese and UK higher education systems, and consequently attempt not to take anything for granted in terms of the related academic conventions and norms. Specifically speaking, in order to avoid making mistakes because of the lack of knowledge about the differences between the two education systems, Chinese students need to communicate with the members of staff more actively whenever they feel uncertain about reading and writing requirements, parts of lectures and lecture handouts, specific places in reading materials, feedback on written assignments, and so on. As was evident in the data analyses in Chapters 6 to 8, Chinese students may not always manage to actively communicate with their tutors due to factors such as an assumption, based on their past experience, that, as a rule, students should not ask for tutors' advice; or the assumption that they could keep their usual way

of handling their studies as they did in China if they did not get special reminders from their current tutors at Lancaster University; or because students sometimes did not get a prompt reply from their current tutors concerning their queries; or because their tutors' answers did not always seem helpful. Indeed, one of the factors that seemed to strongly influence students' desire to communicate with tutors was the tutors' response to their enquiries (mostly via email), which leads to the next point, *viz*: tutors' due responsibilities in realizing the differences between the two education systems.

Thus, in order for Chinese (and other overseas) students to benefit most from their masters' studies at Lancaster University, it would seem advisable for tutors not to assume that Chinese students understand what they are supposed to do in terms of doing readings, writing assignments, attending lectures and seminars, etc. if they don't ask questions, because the students, for various reasons, may keep silent even if they do have questions, as was discussed in the foregoing paragraph. Moreover, as has been shown in several parts of the research data, students' timetables were quite tight over the one year of their masters' programmes, with the consequent time pressures making it very likely that they will neglect to properly take into account some of the crucial differences between the two education systems. Therefore, for this reason also, it can be argued that tutors might do well to remind students as often and as emphatically as possible about the common mistakes that past students have tended to make. Equally, of course, it must also be accepted that tutors have heavy teaching, research and sometimes administrative work loads, and thus have little time to spare on reminding students repeatedly about study procedures. Students therefore also have a major responsibility to pay due attention to the tutors' advice and reminders. However, as the research data have shown, more might have been done not only by students but also by staff, in order to remedy the kinds of problems identified, and so it seems reasonable to

put forward a “modest proposal” of the kind outlined above.

#### ***9.4.3.1.2 Understanding the Language Barrier***

Language, as one of the most essential ‘mediating artefacts’ in the AS of the Lancaster University masters’ programmes that was different from the language used in the students’ past AS in China, is another aspect worth mentioning here. It is advisable to raise the tutors’ and Chinese students’ awareness of the language barrier between them, as there were indications in the data (e.g. transb5:2-3, transb8:3-4) that the Chinese students’ English language competence caused problems in tutor-student communications. For instance, E2’s email greatly offended one of her tutors because of the inappropriate language she used in it. Although E2 did not mean to offend her tutor, her inadequate knowledge of this aspect of English caused part of the problem. Another example was M2’s misuse of the word ‘survey’ (meaning ‘the literature review she did’ in her assignment for the LM module), which made it difficult for her marker to follow her arguments. Such problems of communications were also exacerbated because the tutors did not appear to realize that the Chinese students’ misuse of language may distort the messages they actually intended to convey. On the other hand, the data also show that there were tutors who realized the language problems that the Chinese students might experience: for instance, one of the tutors for the LM module in the MSc. in Management programme mentioned that English language competence affected some Chinese students’ expression of ideas in their essays<sup>1</sup>; one of the tutors for the TLA module in the MA in Education programme acknowledged the Chinese students’ difficulty of reading academic texts in English. However, other members of staff did not appear to have noticed the language barrier or realized how significantly it might affect

---

<sup>1</sup> This tutor said in the interview that “The use of English was a basic issue ... and (it) unfortunately influenced lots of essays in that sense. ... I had problem (sic) trying to understand what the student was saying by some statements, some phrases, because sometimes it was not proper use of language” (transst6:4).



the tutor-student communication, as the very same tutor who mentioned the reading difficulty for Chinese students was the one who was offended by E2's email. Therefore, it would seem advisable for members of staff to always bear in mind the possibility of miscommunication on the part of the Chinese students (and others with similar characteristics of this kind) due to their language competence, and to seek ways of helping Chinese students overcome such language barriers. How such help might be provided will be discussed in section 9.4.3.2 below.

On the other hand, the Chinese students may be equally unaware of the occasions when they are likely to express their ideas wrongly due to the lack of language knowledge. Thus, they may not be on their guard about the miscommunications due to their language competence and hence may not seek due help from various sources. Therefore, to improve the situation, the student should also be more alert and sensitive to the possibility of making language mistakes and should seek help with every possible opportunity in order to avoid such miscommunications.

To sum up, the discussion above has indicated the aspects about which both tutors and Chinese students need to be aware not to make unwarranted assumptions according to their past experiences and usual practice. Data from this study have also demonstrated the undesirable consequences of the lack of awareness of those aspects. Thus, to raise the awareness of both tutors and students, first and foremost, it can be argued that the staff with management responsibility at the university, faculty, department, and programme levels need to inform and remind other academic staff of the changes in the composition of student population and to draw their attention to the potentially necessary measures to be taken due to those changes. Considering the heavy work load on the part of the members of staff, regular communications between the staff (e.g. meetings, memos, emails etc.) should be used as often as possible to remind each

other of the differences between the UK and Chinese education systems. Only after the members of staff are adequately aware of those differences, could they possibly raise the Chinese students' awareness in this respect, by reminding them, repeatedly throughout the whole course of their masters' programmes and especially at certain strategic points such as when the students are about to start working on their assignments, when they are about to submit their assignments, of the possible different academic conventions in the UK university setting compared to those in the students' home universities. Given the pressure on the part of Chinese students of adjusting to the UK education system from a Chinese education background within a relatively short period of time and of attempting to cope with the relatively tight one-year masters' programmes satisfactorily, they may not manage to always bear in mind those differences. Therefore, frequent and repeated reminders from the members of staff seem especially important and necessary.

Awareness raising can be seen as the first crucial step towards a harmonious and constructive tutor-student relationship, which may in turn make the Chinese students' experiences of doing their masters' studies more beneficial and rewarding. However, in addition, providing the kind of support and help that is most needed and in the most appropriate form is also crucial to improving the experience of doing masters' studies of students such as the subjects of this study in universities such as Lancaster, and it is to this issue I turn next.

#### **9.4.3.2 An Appropriate Level of Support**

The reason for arguing that awareness-raising concerning the possible differences between the UK and Chinese education systems is unlikely, on its own, to guarantee to solve the problems which have been identified is evident in the following part of the data from an interview with the LM module lecturer:

If you think they are, most of them, they are educated in a different way, in a different tradition. And then they come here for a year, and they are asked to respect canons and criteria that they don't really know about, they haven't been trained into. That's kind of crazy, as if I come to China and you would ask me to be there and respect all the way. You would ask me to, invite me for a meal. I've got there and I would have made a mess of it because probably the way the formal meal in China works, might have the rituals, canons, procedures, etc. that are very difficult to understand. You can lay them out like I do, explaining you should do it this way, the other way, the other way. You try to explain to people how and what they are supposed to do. And you also write it down so that they can go home and look at it for themselves. But you are not going to learn how to behave properly at a formal dinner in China just because you tell me how to do that. You have to tell me quite a lot of times. I think that's kind of metaphor to explain to you what I think about all these Chinese students, but not only Chinese, also from other countries, (when they) try to do an essay within the English academic system (transst4/2:2, my interpolation).

There were many examples in the discussions of the 'subject'-'community', 'subject'-'rule', and 'subject'-'division of labour' relationships in the four subjects' experiences in doing their assignments to confirm the above point, as the relevant sections in Chapters 6-8 have indicated. For instance, assignment referencing conventions were introduced in the Lancaster University 'study skills' summer programme, in the 'Study Skills Core Module' in the MA in Education programme, and in the academic support course in the MSc. in Management programme; yet E1, E2, M2, and M3 all made referencing mistakes in their assignments. Another example was the critical review tasks in the MA in Education programme. As was discussed in Chapter 7, E1 and E2's first critical review task—the one they did before the assignment reviewed in detail in Chapter 7—yielded quite unsatisfactory results, and they believed that this was mostly because they were not instructed in how to write proper critical reviews. After all the students received their feedback, the convener of the module of the first critical review task spent an hour of one of his teaching sessions on the right way of writing critical reviews, illustrating with good and bad examples from the students' own work. However, neither E1 nor E2 was satisfied with the information given in that session, and found Task A in the TLA module assignment—which was also a critical review—still difficult to deal with, despite the fact that they had been given a lecture session on writing critical reviews. E1 and E2 thought that was because the instructions given by the convener mentioned above were abstract and general, and therefore,

difficult to follow while they were writing (see 7.3.2.3.1).

Therefore, judging by the examples mentioned above, it seems necessary not only to offer academic support to Chinese students as needed, but also to provide the type of support that can effectively serve their needs. Attempts have been made and are planned to be made in this respect as shown in the data of this study. For instance, the convener of the IER module in the MA in Education programme provided exactly the kind of support that helped the Chinese students substantially during the course of doing their first assignment for the IER module: such support included samples of past students' work for similar tasks, detailed extra assignment guidelines in answer to students' questions about the writing requirements, and prompt and constructive replies to individual students' questions via email. Another example was one of the lecturers for the EM module in the MSc. in Management programme, who was thinking actively of the proper ways of helping students when he found they were not using the right type of literature in their assignment, as can be illustrated by the following part of the data from an interview with this lecturer:

There's a lot of Internet (sources). I suppose in the future, what I might do is change the question slightly so there's more academic literature. I think one thing I could improve upon this is to point to them in the direction of more books and more articles and journals. ... I'll probably give the questions so that they do look at more economics articles rather than business articles (transst5/2:4, my interpolation).

The examples of the two lecturers discussed above are good illustrations of offering support and help at the appropriate level of specificity and concreteness to be able to serve the subjects' needs. However, such provision appears currently to take the form of individual initiative, rather than being the result of a more co-ordinated programme or department or institution wide commitment to addressing the problem. It would obviously be better if the latter were more often the case.

### **9.4.3.3 Programme Design**

Discussions in Chapters 6 to 8 indicated that the difficulties and problems that the

subjects experienced while reading for writing their assignments were not only due to the conflicts between the 'subject' and 'community' (members of staff in particular), but also partly rooted in the design of the masters' programmes, and hence may be difficult to avoid re-occurring while the current structures remain unchanged. The different design of the two masters' programmes seem to have made the students' experiences of the two programmes different, not always productively.

#### ***9.4.3.3.1 At the Intra-programme Level***

First of all, there seems to have been a problem in programme design at the intra-programme level, which affected the subjects' experiences in a negative way. As was discussed in 8.2.2.4 above, one difference between the two programmes studied was that the MSc. in Management appeared to be more intensive than the MA in Education. To take the first term as an example, in the MA in Education programme E1 and E2 had two compulsory courses and one support course with only one piece of work due during the first term, whereas in the first term of the MSc. in Management programme, M1 and M2 had four compulsory courses and one elective course, with more than one piece of course work for most courses plus various optional support courses. As a result, M1 and M2 had a great deal of coursework to do and they could not spend much time on each one of them. Consequently, they did not do well at some stages of the whole process of reading for writing, which inevitably affected the results of some of their assignments. E1 and E2 were able to manage their time while doing the assignment for the IER module because they only needed to turn in one piece of written work before the end of the first term and another piece at the beginning of the second term. However, in the second term, E1 experienced much difficulty in time management not only because of her personal characteristics, but also because there were more courses in the second term (four assessed modules) than the first term (two

assessed modules), with more coursework (three pieces of written work and one oral presentation) due over the second term. Among the coursework, two pieces were for the TLA module conducted in the first term. Although some students in the programme coped adequately concerning time management, there were those who, like E1, found these overall scheduling arrangements difficult to cope with (4 out of 16 students got extension, see transa4:16). It can therefore be argued that it would be better if deadlines were arranged so that the students were able to divide up their time more equally, rather than ask for two pieces of work over the first term and Christmas holidays and ten pieces over the second term and Easter holidays. As for the MSc. in Management students, all their tutors that I interviewed knew that the students were short of time. However, none of them seemed happy if the students spent less time on the module that s/he taught. This would therefore appear to call for greater discussion and deliberation by the programme team under the leadership of the programme coordinator in order to attempt to arrive at a consensus regarding a more equitable student workload.

In addition to the programme schedule arrangement, the subject contents that were taught in the programmes may also be presented slightly differently so that students such as the subjects may find the relevance more easily and be better motivated to read about them. For example, E1 complained about the TLA module for its lack of relevance to her teaching situation in China, thus she was uncommitted in doing pre-reading tasks, in listening to the lectures and in participating the discussions in class. The convener of the TLA module, however, thought that the contents taught in this module were relevant to all teaching situations and that the students needed to discover the relevance of those contents to their own situations (see section 5.5.2 above for details). Another example is the LM module which both M1 and M2 found difficult to learn partly because they could not imagine how to put the theory into practice in their

daily life and work in the future, especially for M2, who had no working experiences in the business world before she came to the UK. The convener of the LM module explained in an interview with me (transst4/2:11) how the topics covered in this module were related to the students' future work and the importance of understanding the issues discussed in the module for their future career. In the two cases mentioned above, the problem seems to be that the students, such as E1, E2, M1 and M2, did not see the conveners' intended objectives of the modules. Therefore, it can be argued that the academic staff need to be more explicit about the intended course objectives, and demonstrate more clearly to the students ways in which they may establish the connection between the course contents and their contexts of work in the future. In this way, the students may more easily realize the relevance of the courses to their own situations and be more motivated to reading for those courses.

#### ***9.4.3.3.2 At the Inter-programme Level***

Apart from the possibility of improvement in individual programme design as discussed above, it can be argued that, at the *inter-programme* level too, the data indicate that there is also a need for a more co-ordinated form of development. The data have shown that some of the regulations that applied to the two programmes differed somewhat unhelpfully. For instance, plagiarism seemed to be more seriously prohibited in the MSc. in Management programme, as the students got several emails to remind them of this issue, and a written warning can also be found in the LM module assignment details (appendix 17). Students were asked to submit electronic versions of all coursework so that any suspected cases of plagiarism could be checked by computer software. M2 also constantly mentioned her concern and fear of plagiarizing while she was doing various assignments. However, it does not seem to have been a concern for E1 and E2 as they seldom mentioned it during the interviews that were conducted with

them at different points throughout the first two terms of their programme. All of the students in the MA in Education programme that I interviewed mentioned that they put direct quotations into their writings in the form of indirect citations, i.e. used a form of referencing which could be regarded as plagiarism.

Another difference in the enforcement of regulations that was identified in the data was concerning the extension of deadlines. The students in the MA in Education programme seemed to be able to get generous extensions without necessarily justifiable reasons on more than one occasion (personal communication with E1, March 2005), whereas I seldom heard of any students in the MSc. in Management programme asking for extensions. Instead, they usually worked around the clock to meet different deadlines. Also, in the MSc. LM module assessment details, it was stated that 'No extension will be granted unless medical certification is provided and the rules from your programme handbook are followed' (emphasis in original, appendix 17). On the one hand, granting an extension eased the pressure on the students who could not manage to turn in their work on time (such as E1, due to her late start, lack of reference resources and emotional breakdown); but on the other hand, it seems to have been unfair to those who do submit on time (such as M1, who struggled very much and did manage to meet the deadline but only got a 50 for that assignment, and who given more time may very likely get a better result).

In short, at the intra-programme level, it can be argued that more effort needs to be made to make sure that the workload and the timetable is manageable, especially taking into consideration the overseas students' disadvantage in this respect; and that the subject content is made explicitly relevant to all students. Similarly, at the faculty and university level, more co-ordinated effort might be made, it can be argued, to make sure that clear and consistent inter-programme policies have been articulated and



implemented so as to achieve better clarity for the students concerning the expectations.

Having discussed the pedagogical implications that can be drawn from the study, I now turn to a consideration of its limitations and the possibilities for future research.

## **9.5 Limitations of the Study and Directions for Further Research**

This study has presented a picture of Chinese postgraduate students' academic reading practices by examining four cases in two masters' programmes in Lancaster University, and exploring the effects of their past literacy and education experiences and their current contexts on their academic reading experiences. The scope of the research has been limited by the time available on the one hand, and a desire to provide sufficient in-depth detail on the other. Thus, to add to the richness of the picture presented by the current study, the same kind of research could be done with respect to students studying on other subject areas, with respect to larger numbers of students, with students who may have some different background characteristics (e.g. different undergraduate specialisms), students in other UK higher education institutions, and students from countries other than China, in order to see the extent to which and the ways in which such students' educational backgrounds and literacy histories may have effect on their current literacy experiences. Another possible way to expand the current study would be to investigate Chinese students doing *undergraduate* studies in UK higher education institutions such as Lancaster University. On the one hand, a more comprehensive picture of the Chinese students' UK academic reading practices would be revealed. On the other, an insight could be gained into the difference made to postgraduate students' literacy practices by virtue of their having undergone English language education in particular and higher education in general in China beforehand. Still another way of expanding the research, as discussed in 3.3.3 above, is to investigate Chinese postgraduate students' academic reading practices in Chinese

universities in order to see how different and similar Chinese students' reading practices are under two different postgraduate education systems, thus finding out to what extent the students' academic reading practices are affected by the discontinuity between the undergraduate and postgraduate education systems.

Also, the combined NLS and AT framework established and effectively applied in this study can and should be applied further in literacy studies in various contexts within or without the area of education, and applied to a variety of groups of subjects with different mother tongues, educational backgrounds, because of the richer picture of the matter of both L1 and L2 (depending on the focus of the study) academic reading practices that might be yielded, as shown in this thesis. The tendency is still, especially within L2-based studies of literacy practices, to look at the matter from a narrower, more technical viewpoint. The theoretical framework used in this study, if taken up and used more widely, might provide a viable means of encouraging growth in alternative, broader and less reductionist perspective.

## **9.6 Final Remarks**

Through a study of Chinese postgraduate students' academic literacy practices in the UK higher education system, this thesis has attempted to explore the potential of a theoretical framework that views reading and writing not only in terms of individual cognitive processing, but also as social activities involving interacting aspects in one's past experiences and current contexts. In doing so, it has argued for the compatibility of the NLS and AT schools of thought, and thus the strengths of combining the NLS and AT conceptual frameworks in literacy studies research. The process of data analysis in this thesis has illustrated one possible way of applying a combined framework of this kind in a specific study.

This thesis has offered a close-up look at the details of Chinese postgraduate

students' academic literacy practices and the interacting factors that shaped such literacy practices, thus helping to further the understanding of Chinese students' literacy experiences during their studies in a UK higher education institution such as Lancaster University. Accordingly, suggestions regarding the design of masters' programmes and the subject area teaching have been put forward in order to make the Chinese students' experiences of doing masters' studies in the UK higher education context more rewarding and beneficial. Pedagogical implications for ELT and EAP programmes in both China and UK have also been pointed out with a view to helping Chinese students better and more quickly adjust to the new educational contexts, and thus benefit more from their studies overseas. Finally, directions for possible future studies have been suggested so as to yield a more comprehensive picture of the Chinese postgraduate students' academic literacy experiences in universities in English speaking countries, and to further add to the development of the theoretical framework used in this study. It is hoped that this thesis as a whole will therefore prove of value to the teachers and researchers to whom it is of potential relevance.

## Bibliography

- Afflerbach, P. P., & Johnston, P. H. (1986). What do Expert Readers Do When the Main Idea is not Explicit. In J. F. Baumann (Ed.), *Teaching Main Idea Comprehension*. Newark: International Reading Association.
- Ahmad, I. S., & Asraf, M. R. (2004). Making Sense of Text : Strategies Used by Good and Average Readers. *The Reading Matrix*, 4(1), 26-37.
- Alderson, J. C., & Urquhart, A. H. (1988). This Test is Unfair : I'm not an Economist. In P. L. Carrell, J. Devine & D. E. Eskey (Eds.), *Interactive Approaches to Second Language Reading*. Cambridge: Cambridge University Press.
- Alfassi, M. (2004). Reading to Learn: Effects of Combined Strategy Instruction on High School Students. *The Journal of Educational Research*, 97(4), 171-184.
- Altheide, D. L., & Johnson, J. M. (1998). Criteria for Assessing Interpretive Validity in Qualitative Research. In N. K. Denzin & Y. S. Lincoln. (Eds.), *Collecting and Interpreting Qualitative Materials*. Thousand Oaks, CA: Sage.
- Anderson, N. (1991). Individual Differences in Strategy Use in Second Language Reading and Testing. *Modern Language Journal*, 75, 460-472.
- Arksey, H., & Knight, P. (1999). *Interviewing for Social Scientists: an Introductory Resource with Examples*. Thousand Oaks, CA: Sage.
- Atkinson, P., Coffey, A., Delamont, S., Lofland, J., & Lofland, L. (Eds.). (2001). *Handbook of Ethnography*. London: Sage.
- Atkinson, R. (2001). The Life Story Interview. In J. F. Gubrium & J. A. Holstein (Eds.), *Handbook of Interview Research*. Thousand Oaks, CA: Sage.
- Baker, C., & Luke, A. (Eds.). (1991). *Towards a Critical Sociology of Reading Pedagogy : Papers of the XII World Congress on Reading*. Amsterdam: John Benjamins.
- Barton, D. (1994). *Literacy : An Introduction to the Ecology of Written Language*. Oxford: Blackwell Publishers.
- Barton, D., & Hamilton, M. (1998). *Local Literacies*. London: Routledge.
- Barton, D., & Padmore, S. (1991). Roles, Networks and Values in Everyday Writing. In D. Barton & R. E. Ivanič (Eds.), *Writing in the Community*. Newbury Park, CA.: Sage.
- Bateson, M. C. (1994). *Peripheral Visions: Learning along the Way*. New York: HarperCollins.
- Baynham, M. (1995). *Literacy Practices: Investigating Literacy in Social Context*. London: Longman.

- Baynham, M. (2001). Reading the Weather: Ruling Passions, Numeracy and Reading Practices in an Australian Farming Community. *Journal of Research in Reading*, 24(3), 307-312.
- Baynham, M., & Baker, D. (2002). 'Practice' in Literacy and Numeracy Research: Multiple Perspectives. *Ways of Knowing Journal*, 2(1), 1-9.
- BBC-News. (Feb 17, 2005). UK study applicants are up 8.9%. Retrieved Sept 9, 2005, from [newsvote.bbc.co.uk/mpapps/pagetools/print/news.bbc.co.uk/1/...](http://newsvote.bbc.co.uk/mpapps/pagetools/print/news.bbc.co.uk/1/...)
- Bell, J. (2002). Framing and Text Interpretation across Languages and Cultures: a Case Study. In J. Flowerdew (Ed.), *Academic Discourse*. London: Longman.
- Bell, J. (2005). Cultural Shifts: A Longitudinal Study of the Changing Reading Practices of Thai Postgraduate Students at an Australian University. *The Reading Matrix*, 5(1), 85-105.
- Bell, J. S. (1997). Shifting Stories: Shifting Frames. In C. P. Casanave & S. Schecter (Eds.), *On Becoming a Language Educator*. Hillsdale, NJ.: Erlbaum.
- Bell, J. S. (1997a). *Literacy, Culture, and Identity*. New York: Peter Lang.
- Bell, J. S. (2002). Narrative Inquiry: More than just Telling Stories. *TESOL Quarterly*, 36(2), 207-213.
- Berman, R., & Slobin, D. (1994). *Relating Events in Narrative: a Crosslinguistic Developmental Study*. Mahwah, NJ.: Erlbaum.
- Bernhardt, E. B. (1991). A Psycholinguistic Perspective on Second Language Literacy. In J. H. Hulstijn & J. F. Matter (Eds.), *Reading in Two Languages*. Amsterdam: IALA Review 8.
- Bernhardt, E. B. (1991a). *Reading Development in a Second Language*. Norwood, NJ: Ablex.
- Bernhardt, E. B. (2000). Second-Language Reading as a Case Study of Reading Scholarship in the 20th Century. In M. L. Kamil, P. D. Pearson, R. Barr & P. Mosenthal (Eds.), *Handbook of Reading Research Vol. 3*. Mahwah N.J.: Lawrence Erlbaum Associates.
- Besnier, N. (1993). Literacy and Feelings: the Encoding of Affect in Nukulaelae Letters. In B. V. Street (Ed.), *Cross-cultural Approaches to Literacy*. Cambridge: Cambridge University Press.
- Besnier, N. (1995). *Literacy, Emotion and Authority: Reading and Writing on a Polynesian Atoll*. Cambridge: Cambridge University Press.
- Bhaskar, R. (1978 ). *A Realist Theory of Science*. Hassocks, Sussex: Harvester Press.
- Bhaskar, R. (1998 ). *The Possibility of Naturalism : a Philosophical Critique of the Contemporary Human Sciences* ( 3rd ed.). London: Routledge.

- Biernacki, P., & Waldorf, D. (1981). Snowball sampling: problems and techniques of chain referral sampling. *Sociological Methods & Research*, 10, 141-163.
- Blackler, F., & Kennedy, A. (2004). The Design and Evaluation of a Leadership Programme for Experienced Chief Executives from the Public Sector. *Management Learning*, 35(2), 179-201.
- Blackler, F., Crump, N., & McDonald, S. (1999). Organizational Learning and Organizational Forgetting: Lessons from a High Technology Company. In M. Easterby-Smith, J. Burgoyne & L. Araujo (Eds.), *Organizational Learning and the Learning Organization*. London: Sage.
- Blackler, F., Crump, N., & McDonald, S. (1999a). Managing Experts and Competing through Innovation: an Activity Theoretical Analysis. *Organization*, 6(1), 5-31.
- Blackler, F., Crump, N., & McDonald, S. (2000). Organizing Processes in Complex Activity Networks. *Organization*, 7(2), 277-300.
- Block, E. (1986). The Comprehension Strategies of Second Language Readers. *TESOL Quarterly*, 20(3), 463-494.
- Bomer, R. (2003). Things that Make Kids Smart: a Vygotskian Perspective on Concrete Tool Use in Primary Literacy Classrooms. *Journal of Early Childhood Literacy*, 3(3), 223-247.
- Bourdieu, P. (1977). *Outline of a Theory of Practice*. Cambridge: Cambridge University Press.
- Brantmeier, C. (2005). Readings on L2 Reading : Publications in Other Venues 2004-2005. *Reading in a Foreign Language*, 17(2), 159-167.
- Brantmeier, C. (2005b). Effects of Reader's Knowledge, Text Type, and Test Type on L1 and L2 Reading Comprehension in Spanish. *The Modern Language Journal*, 89, 37-53.
- Brown, A., Armbruster, B., & Baker, L. (1983). The Role of Metacognition in Reading and Studying. In J. Orsany (Ed.), *Reading Comprehension : From Research to Practice*. Hillsdale, NJ.: Lawrence Erlbaum.
- Bruner, J. (1985). Narrative and Paradigmatic Modes of Thought. In E. Eisner (Ed.), *Learning and Teaching the Ways of Knowing*. Chicago: The National Society for the Study of Education.
- Carr, D. (1986). *Time, Narrative and History*. Bloomington: Indiana University Press.
- Carrell, P. L. (1984). Evidence of a Formal Schema in Second Language Comprehension. *Language Learning*, 34, 87-112.
- Carrell, P. L. (1987). Content and Formal Schemata in ESL Reading. *TESOL Quarterly*, 21(3), 461-481.
- Carrell, P. L. (1989). Metacognitive Awareness and Second Language Reading. *Modern*

*Language Journal*, 73, 121-134.

- Carrell, P. L., & Carson, J. G. (1997). Extensive and Intensive Reading in an EAP Setting. *English for Specific Purposes*, 16(1), 47-60.
- Carrell, P. L., Carson, J. G., & Zhe, D. (1993). First and Second Language Reading Strategies: Evidence from Cloze. *Reading in a Foreign Language*, 10(1), 953-965.
- Carter, K. (1993). The Place of Story in the Study of Teaching and Teacher Education. *Educational Researcher*, 22(1), 5-12, 18.
- Chambliss, M. J. (1995). Text Cues and Strategies Successful Readers Use to Construct the Gist of Lengthy Written Arguments. *Reading Research Quarterly*, 30(4), 778-807.
- Chen, Q., & Donin, J. (1997). Discourse Processing of First and Second Language Biology Texts : Effects of Language proficiency and Domain-specific Knowledge. *Modern Language Journal*, 81, 209-227.
- Chiappe, P., Chiappe, D., & Gottardo, A. (2004). Vocabulary, Context, and Speech Perception among Good and Poor Readers. *Educational Psychology*, 24(6), 825-843.
- Clandinin, D. J., & Connelly, F. M. (1995). *Teachers' Professional Knowledge Landscapes*. New York: Teachers College Press.
- Clandinin, D. J., & Connelly, F. M. (1996). Teachers' Professional Knowledge Landscapes: Teacher Stories-Stories of Teachers-School Stories-Stories of Schools. *Educational Researcher*, 25(3), 24-30.
- Clandinin, D. J., & Connelly, F. M. (1998). Personal Experience Methods. In N. K. Denzin & Y. S. Lincoln. (Eds.), *Collecting and Interpreting Qualitative Materials*. Thousand Oaks: Sage Publications.
- Clandinin, D. J., & Connelly, F. M. (2000). *Narrative Inquiry: Experience and Story in Qualitative Research*. San Francisco: Jossey-Bass.
- Connelly, F. M., & Clandinin, D. J. (1987). On Narrative Method, Biography and Narrative Unities in the Study of Teaching. *Journal of Educational Thought*, 21, 130-139.
- Connelly, F. M., & Clandinin, D. J. (1988). *Teachers as Curriculum Planners: Narratives of Experience*. New York: Teachers College Press.
- Contreras E, G. A. (2000). Self-storying, Self-understanding: toward a Narrative Approach to EFL Teacher Education. *TESOL Journal*, autumn 2000, 24-27.
- Cornu, R. L., & Collins, J. (2004). Re-Emphasizing the Role of Affect in Learning and Teaching. *Pastoral Care in Education*, 22(4), 27-.
- Cortazzi, M., & Jin, L. (1996). Cultures of Learning: Language Classrooms in China. In

- H. Coleman (Ed.), *Society and the Language Classroom*. Cambridge: Cambridge University Press.
- Czarniawska, B. (2001). Narrative, Interviews, and Organizations. In J. F. Gubrium & J. A. Holstein (Eds.), *Handbook of Interview Research*. Thousand Oaks, CA: Sage.
- Davey, B. (1987). Relations between Word Knowledge and Comprehension : Generalization across Tasks and Readers. *Journal of Educational Research*, 80(3), 179-183.
- Dymock, S. (2005). Teaching Expository Text Structure Awareness. *The Reading Teacher*, 59(2), 177-181.
- Elbaz, F. (1983). *Teacher Thinking: a Study of Practical Knowledge*. London: Croom Helm.
- Engeström, Y. (1987). *Learning by Expanding: an Activity-Theoretical Approach to Developmental Research*. Helsinki: Orienta-Konsultit Oy.
- Engeström, Y. (1990). *Learning, Working and Imagining: Twelve Studies in Activity Theory*. Helsinki: Orienta-Konsultit Oy.
- Engeström, Y. (1995). Objects, Contradictions and Collaboration in Medical Cognition: an Activity-theoretical Perspective. *Artificial Intelligence in Medicine*, 7(5), 395-412.
- Engeström, Y. (1999). Activity Theory and Individual and Social Transformation. In Y. Engeström, R. Miettinen & R. Punamäki (Eds.), *Perspectives on Activity Theory*. Cambridge: Cambridge University Press.
- Engeström, Y., Miettinen, R., & Punamäki, R. (Eds.). (1999). *Perspectives on Activity Theory*. Cambridge: Cambridge University Press.
- Fingeret, A. (1983). Social Networks: Independence and Adult Illiterates. *Adult Education Quarterly*, 33(3), 133-146.
- Fukkink, R. G., Hulstijn, J., & Simis, A. (2005). Does Training in Second-Language Word Recognition Skills Affect Reading Comprehension? An Experimental Study. *The Modern Language Journal*, 89, 54-75.
- Gardner, R. C., & MacIntyre, P. D. (1991). An Instrumental Motivation in Language Study: Who Says It Isn't Effective? *Studies in Second Language Acquisition*, 13(1), 57-72.
- Garner, R., & Krauss, K. (1982). Good and Poor Comprehender Differences in Knowing and Regulating Reading Behavior. *Educational Research Quarterly*, 6, 5-12.
- Gee, J. P. (1996). *Social Linguistics and Literacies : Ideology in discourses* (Second ed.). London: Taylor & Francis Ltd.



- Gee, J. P. (2000). The New Literacy Studies : From 'Socially Situated' to the Work of the Social. In D. Barton, M. Hamilton & R. E. Ivanič (Eds.), *Situated Literacies : Reading and Writing in Context*. London: Routledge.
- Gee, J. P. (2000a). Discourse and Sociocultural Studies in Reading. In M. L. Kamil, P. D. Pearson, R. Barr & P. Mosenthal (Eds.), *Handbook of Reading Research* (Vol. 3). Mahwah, NJ.: Lawrence Erlbaum Associates.
- Gee, J. P. (2004). New Times and New Literacies: Themes for a Changing World. In A. F. Ball & S. W. Freedman (Eds.), *Bakhtinian Perspectives on Language, Literacy, and Learning*. Cambridge: Cambridge University Press.
- Geertz, C. (1995). *After the Fact : Two Countries, Four Decades, One Anthropologist*. Cambridge, Mass.: Harvard University Press.
- Golombek, P. R. (1998). A Study of Language Teachers' Personal Practical Knowledge. *TESOL Quarterly*, 32(3), 447-464.
- Goodwin, C., & Duranti, A. (1992a). Rethinking Context: An Introduction. In A. Duranti & C. Goodwin (Eds.), *Rethinking Context: Language as an Interactive Phenomenon*. Cambridge: Cambridge University Press.
- Goodwin, D., Pope, C., Mort, M., & Smith, A. (2003). Ethics and Ethnography: An Experiential Account. *Qualitative Health Research*, 13(4), 567-577.
- Goody, J., & Watt, I. (1988). The Consequences of Literacy. In E. R. Kintgen, B. M. Kroll & M. Rose (Eds.), *Perspectives on Literacy*. Carbondale: Southern Illinois University Press.
- Gough, K. (1988). Implications of Literacy in Traditional China and India. In E. R. Kintgen, B. M. Kroll & M. Rose (Eds.), *Perspectives on Literacy*. Carbondale: Southern Illinois University Press.
- Gudmundsdottir, S. (1991). Story-maker, story-teller: narrative structures in curriculum. *Journal of Curriculum Studies*, 23(3), 207-218.
- Guikema, J. P. (2004). *Learners as Agents of Development: an Activity Theory and Folk Linguistic Analysis of Foreign Language Literacy*. Unpublished PhD thesis, Pennsylvania State University.
- Guillund, B. (1996). Allocation of Attention during Word Recognition by Good and Poor Readers. *Perceptual and Motor Skills*, 82(3), 899.
- Halliday, M. A. K., & Hasan, R. (1989). *Language, Context, and Text: Aspects of Language in a Social-semiotic perspective* (2nd ed.). Oxford: Oxford University Press.
- Hammadou, J. (2000). The Impact of Analogy and Content Knowledge on Reading Comprehension : What Helps, What Hurts. *Modern Language Journal*, 84, 38-50.
- Hammersley, M., & Atkinson, P. (1995). *Ethnography: Principles in Practice* (2nd ed.).

London: Routledge.

- Haynes, N. M., Ben-Avie, M., & Ensign, J. (Eds.). (2003). *How Social and Emotional Development Add up: Getting Results in Math and Science Education*. New York: Teachers College Press.
- Heath, S. B. (1983). *Ways with Words*. Cambridge: Cambridge University Press.
- Heyl, B. S. (2001). Ethnographic Interviewing. In P. Atkinson, A. Coffey, S. Delamont, J. Lofland & L. Lantolf (Eds.), *Handbook of Ethnography*. London: Sage.
- Horiba, U. (2000). Reader Control in Reading: Effects of Language Competence, Text Type and Task. *Discourse Processes*, 29(3), 223-267.
- Horsman, J. (1994). The Problem of Illiteracy and the Promise of Literacy. In M. Hamilton, D. Barton & R. E. Ivanič (Eds.), *Worlds of Literacy*. Clevedon, Avon: Multilingual Matters.
- Horsman, J. (2000). *Too Scared to Learn: Women, Violence and Education*. Mahwah: N.J.: L Erlbaum.
- Hosenfeld, C. (1977). A Preliminary Investigation of the Reading Strategies of Successful and Non-successful Second Language Learners. *System*, 5, 110-123.
- Hudson, T. (1988). The Effects of Induced Schemata on the "Short Circuit" in L2 Reading : Non-decoding Factors in L2 Reading Performance. In P. L. Carrell, J. Devine & D. E. Eskey (Eds.), *Interactive Approaches to Second Language Reading*. Cambridge: Cambridge University Press.
- Ivanič, R. E. (1997). *Writing and Identity : the Discoursal Construction of Identity in Academic Writing*. Amsterdam: John Benjamins.
- Johnson, D. (2003). Activity Theory, Mediated Action and Literacy: Assessing How Children Make Meaning in Multiple Modes. *Assessment in Education*, 10(1), 103-129.
- Johnson, J. M. (2001). In-depth Interviewing. In J. F. Gubrium & J. A. Holstein (Eds.), *Handbook of Interview Research*. Thousand Oaks, CA.: Sage.
- Johnstone, B. (1996). *The Linguistic Individual: Self-expression in Language and Linguistics*. New York: Oxford University Press.
- Jones, A., & Issroff, K. (2005). Learning Technologies: Affective and Social Issues in Computer-supported Collaborative Learning. *Computers and Education*, 44(4), 395-408.
- Jones, C., Turner, J., & Street, B. (Eds.). (1999). *Students Writing in the University : Cultural and Epistemological Issues*. Amsterdam: John Benjamins.
- Kamil, M. L., Pearson, P. D., Barr, R., & Mosenthal, P. (Eds.). (2000). *Handbook of Reading Research Vol. 3*. Mahwah N.J.: Lawrence Erlbaum Associates.

- Kanno, Y. (2000). Bilingualism and Identity: the Stories of Japanese Returnees. *International Journal of Bilingual Education and Bilingualism*, 3, 1-18.
- Keating, M. C. (2001). *Routes Through Literacy : the Lived Experiences with Literacy of Portuguese Women in London*. Unpublished PhD thesis, Lancaster University, Lancaster.
- Knight, S., Padron, Y., & Waxman, H. C. (1985). The Cognitive Reading Strategies of ESL Students. *TESOL Quarterly*, 19, 789-792.
- Kubota, R. (1999). Japanese Culture Constructed by Discourses: Implications for Applied Linguistics Research and ELT. *TESOL Quarterly*, 33(1), 9-35.
- Lau, K., & Chan, D. W. (2003). Reading Strategy Use and Motivation among Chinese Good and Poor Readers in Hong Kong. *Journal of Research in Reading*, 26(2), 177-190.
- Lea, M. R., & Stierer, B. (Eds.). (2000). *Student Writing in Higher Education*. Buckingham: SRHE and Open University Press.
- Lea, M. R., & Street, B. V. (1998). Student Writing in Higher Education: an academic literacy approach. *Studies in Higher Education*, 23(2), 157-172.
- Leki, I. (2003). Living through College Literacy. *Written Communication*, 20(1), 81-98.
- Leont'ev, A. N. (1978). *Activity, Consciousness, and Personality* (M. J. Hall, Trans.). Englewood Cliffs, N.J.: Prentice-Hall Inc.
- Lieblich, A., Tuval-Mashiach, R., & Zilber, T. (1998). *Narrative Research: Reading Analysis and Interpretation*. Newbury Park, CA.: Sage.
- Lillis, T. M. (2001). *Student Writing : Access, Regulation, Desire*. London: Routledge.
- Liu, D. (2005). Plagiarism in ESOL Students: is Cultural Conditioning Truly the Major Culprit? *ELT Journal*, 59(3), 234-241.
- Lubliner, S., & Smetana, L. (2005). The Effects of Comprehensive Vocabulary Instruction on Title I Students' Metacognitive Word-learning Skills and Reading Comprehension. *Journal of Literacy Research*, 37(2), 163-200.
- Luke, A., & Baker, C. (1991). Towards a Critical Sociology of Reading Pedagogy : an Introduction. In C. Baker & A. Luke (Eds.), *Towards a Critical Sociology of Reading Pedagogy : Papers of the XII World Congress on Reading*. Amsterdam: John Benjamins
- Luxon, T., & Peelo, M. (2006). *The Role of Curriculum Design in Reconceptualising Academic Support for International Students*. Paper presented at the Internationalising the Curriculum: Working with Students in an International Environment Forum. May 2006. Lancaster University. Lancaster, UK.
- Malinowski, B. (1923). The Problem of Meaning in Primitive Languages. In C. K. Ogden & I. A. Richards (Eds.), *The Meaning of Meaning*.

- Mann, S. J. (2000). The Student's Experience of Reading. *Higher Education*, 39, 297-317.
- Martinez, A. C. L. (2002). Empirical Examination of EFL Readers' Use of Rhetorical Information. *English for Specific Purposes*, 21, 81-98.
- Marx, K. (1974). *The German ideology*. London: Lawrence & Wishart.
- Marx, K. (1975). *Grundrisse*. Harmondsworth: Penguin.
- Marx, K., & Engels, F. (1975). *Works* (R. D. e. al., Trans.). London: Lawrence & Wishart.
- Mason, J. (2002). *Qualitative Researching* (2nd ed.). London: Sage.
- Mishler, E. G. (1986). *Research Interviewing : Context and Narrative*. Cambridge, Mass.: Harvard University Press.
- Mutawa, N. A. A., & Islam, N. (1994). Evaluation of an EAP Reading Course at the Faculty of Education, Kuwait University. *Reading in a Foreign Language*, 10(2), 21-32.
- Nassaji, H. (2004). The Relationship between Depth of Vocabulary Knowledge and L2 Learners' lexical Inferencing Strategy Use and Success. *Canadian Modern Language Review*, 61(1), 107-134.
- Olson, D. R. (1988). From Utterance to Text : the Bias of Language in Speech and Writing. In E. R. Kintgen, B. M. Kroll & M. Rose (Eds.), *Perspectives on Literacy*. Carbondale: Southern Illinois University Press.
- O'Neil, H. F., & Spielberger, C. D. (Eds.). (1979). *Cognitive and Affective Learning Strategies*. New York: Academic Press.
- Ong, W. J. (1988). Some Psychodynamics of Orality. In E. R. Kintgen, B. M. Kroll & M. Rose (Eds.), *Perspectives on Literacy*. Carbondale: Southern Illinois University Press.
- Oppenheim, A. N. (1992). *Questionnaire Design, Interviewing, and Attitude Measurement* (New ed.). London: Pinter Publishers.
- Parry, K., & Su, w. X. (Eds.). (1998). *Culture, Literacy, and Learning English: Voices from Chinese Classroom*. Portsmouth, NH: Boynton/Cook.
- Pavlenko, A. (2002). Narrative Study: Whose Story Is It, Anyway? *TESOL Quarterly*, 36(2), 213-218.
- Pavlenko, A., & Lantolf, J. (2000). Second Language Learning as Participation and the (Re)construction of Selves. In J. Lantolf (Ed.), *Sociocultural Theory and Second Language Learning*. New Haven, CT: Yale University Press.
- Peelo, M. T. (1994). *Helping Students with Study Problems*. Buckingham: SRHE and Open University Press.

- Penney, T. B., Leung, K. M., Chan, P. C., Meng, X., & McBride-Chang, C. (2005). Poor Readers of Chinese Respond Slower than Good Readers in Phonological, Rapid Naming, and Interval Timing Tasks. *Annals of Dyslexia*, 55(1), 9-27.
- Polkinghorne, D. E. (1988). *Narrative Knowing and the Human Sciences*. Albany: State University of New York Press.
- Pulido, D. (2004). The Relationship between Text Comprehension and Second Language Incidental Vocabulary Acquisition : A Matter of Topic Familiarity. *Language Learning*, 54(3), 469-523.
- Punch, M. (1994). Politics and Ethics in Qualitative Research. In N. K. Denzin & Y. S. Lincoln (Eds.), *Handbook of Qualitative Research*. Thousand Oaks: Sage.
- Rathbun, G. A. (1999). *Portraying the Work of Instructional Designing : an Activity-oriented Analysis*. Unpublished PhD thesis, Indiana University.
- Ridgway, T. (1997). Thresholds of the Background Knowledge Effect in Foreign Language Reading. *Reading in a Foreign Language*, 11(1), 151-168.
- Riessman, C. K. (1993). *Narrative Analysis*. Newbury Park, CA.: Sage.
- Robinson, S. (2006). *Embedding Language and Learning Support for International Students*. Paper presented at the Internationalising the Curriculum: Working with Students in an International Environment Forum. May 2006. Lancaster University. Lancaster, UK.
- Rockhill, K. (1993). Gender, Language and the Politics of Literacy. In B. V. Street (Ed.), *Cross-cultural Approaches to Literacy*. Cambridge: Cambridge University Press.
- Rowling, L. (1999). Being In, Being Out, Being With: Affect and the Role of the Qualitative Researcher in Loss and Grief Research. *Mortality*, 4(2), 167-181.
- Rubin, B., Katznelson, H., & Perpignan, H. (2005). Learning for Life: the Potential of Academic Writing Courses for Individual EFL Learners. *System*, 33(1), 17-27.
- Säljö, R. (1984). Learning from Reading. In F. Marton, D. Hounsell & N. Entwistle (Eds.), *The Experience of Learning*. Edinburgh: Scottish Academic Press.
- Sarbin, T. R. (1986). The Narrative as a Root Metaphor for Psychology. In T. R. Sarbin (Ed.), *Narrative Psychology: the Storied Nature of Human Conduct*. New York: Praeger Publishers.
- Scribner, S. (1985). Vygotsky's Uses of History. In J. Wertsch (Ed.), *Culture, Communication, and Cognition: Vygotskian Perspectives*. Cambridge: Cambridge University Press.
- Scribner, S., & Cole, M. (1981). *The Psychology of Literacy*. Cambridge: Harvard University Press.
- Scribner, S., & Cole, M. (1988). Unpacking Literacy. In E. R. Kintgen, B. M. Kroll & M.

- Rose (Eds.), *Perspectives on Literacy*. Carbondale: Southern Illinois University Press.
- Sherman, J. (1992). Your Own Thoughts in Your Own Words. *ELT Journal*, 46(2), 190-198.
- Silverman, D. (2005). *Doing Qualitative Research : a Practical Handbook* (2nd ed.). London: SAGE.
- Singhal, M. (2001). Reading Proficiency, Reading Strategies, Metacognitive Awareness and L2 Readers. *The Reading Matrix*, 1(1), 1-23.
- Singleton, R. A., & Straits, B. C. (2001). Survey Interviewing. In J. F. Gubrium & J. A. Holstein (Eds.), *Handbook of Interview Research*. Thousand Oaks, CA.: Sage.
- Sowden, C. (2005). Plagiarism and the Culture of Multilingual Students in Higher Education Abroad. *ELT Journal*, 59(3), 226-233.
- Spolsky, B. (1969). Attitudinal Aspects of Second Language Learning. *Language Learning*, 19, 271-285.
- Spolsky, B. (2000). Language Motivation Revisited. *Applied Linguistics*, 21(2), 157-169.
- Spradley, J. P. (1979). *The Ethnographic Interview*. Orlando, FL.: Harcourt Brace Jovanovich.
- Stoller, F. L. (1994). Developing a Focused Reading Lab for L2 Students. *Reading in a Foreign Language*, 10(2), 33-53.
- Street, B. V. (1984). *Literacy in Theory and Practice*. Cambridge: Cambridge University Press.
- Street, B. V. (Ed.). (1993). *Cross-Cultural Approaches to Literacy*. New York, N.Y.: Cambridge University Press.
- Street, B. V. (1993a). Introduction: the New Literacy Studies. In B. V. Street (Ed.), *Cross-Cultural Approaches to Literacy*. New York, N.Y.: Cambridge University Press.
- Street, B. V. (1993b). The New Literacy Studies, guest editorial. *Journal of Research in Reading*, 16(2), 81-97.
- Street, B. V. (1995). *Social Literacies: Critical Approaches to Literacy in Development, Ethnography and Education*. London: Longman.
- Taillefer, G. (2005). Reading for Academic Purposes: the Literacy Practices of British, French and Spanish Law and Economics Students as Background for Study Abroad. *Journal of Research in Reading*, 28(4), 435-451.
- Taylor, P., & Beekes, W. (2006). *Accounting and Finance: Integrating Skills' Development into the Curriculum*. Paper presented at the Internationalising the Curriculum: Working with Students in an International Environment Forum.

May 2006. Lancaster University. Lancaster, UK.

- Toledo, P. (2005). Genre Analysis and Reading of English as a Foreign Language: Genre Schemata Beyond Text Typologies. *Journal of Pragmatics*, 37(7), 1059-1079.
- Universities-UK. (2005). Treasury Committee: Impact of China on the World and UK Economy - Memorandum from Universities UK. Retrieved Sept 9, 2005, from [www.universitiesuk.ac.uk/parliament/showEvidence.asp?id=26](http://www.universitiesuk.ac.uk/parliament/showEvidence.asp?id=26)
- Vygotsky, L. S. (1978). *Mind in Society*. Cambridge: Harvard University Press.
- Walmsley, J. (2004). Inclusive Learning Disability Research: the (Nondisabled) Researcher's Role. *British Journal of Learning Disabilities*, 32, 65-71.
- Walsleben, M. C. (1988). *The Effect of Integrative/instrumental Motivation on the Expository Writing Proficiency of Unskilled English as a Second Language Writers*. Unpublished PhD thesis. UCLA.
- Wasson, B. B., Beare, P. L., & Wasson, J. B. (1990). Classroom Behavior of Good and Poor Readers. *The Journal of Educational Research*, 83(3), 162-165.
- Watkins, D. A., & Biggs, J. B. (Eds.). (1996). *The Chinese Learner: Cultural, Psychological and Contextual Influences*. Hong Kong: CERC and ACER.
- Weiss, R. S. (1995). *Learning from Strangers: the Art and Method of Qualitative Interview Studies*. New York, NY.: Free Press.
- Wenger, M. J. (1993). Reduced Text Structure at 2 Text Level--Impact on the Performance of Technical Readers. *Journal of Technical Writing and Communication*, 23(4), 333-352.
- Wertsch, J. (Ed.). (1985). *Culture, Communication, and Cognition: Vygotskian Perspectives*. Cambridge: Cambridge University Press.
- White, H. (1981). The Value of Narrativity in the Representation of Reality. In W. J. T. Mitchell (Ed.), *On Narrative*. Chicago: The University of Chicago Press.
- Wood, K. D., & Endres, C. (2004). Motivating Student Interest with the Imagine, Elaborate, Predict, and Confirm Strategy. *The Reading Teacher*, 58(4), 346-357.
- Wu, Z. (2002). *Teachers' 'Knowledge' and Curriculum Change: a Critical Study of Teachers' Exploratory Discourse in a Chinese University*. Unpublished PhD. Thesis, Lancaster University.

## Appendix 1: Questions for the first interviews with students

- I. Family background
- Where are you from?
  - What do your parents do?
  - Are there any other members in your family?
  - Where did you grow up?
  - Where did you go to school?
  - From which university did you graduate?
- II. Reading before schooling
- Do you remember when you start reading?
  - What, why and how did you read at that time?
  - What help did you get when you read?
  - If you didn't read anything before you went to school, what do you think was the reason?
- III. Learning to read and write in L1 at school and L1 reading outside school
- When did you start schooling?
  - What did you usually do in Chinese class at school?
  - How did you learn the texts in class?
  - Did you experience any difficulty in reading textbooks?
  - Did you read anything except Chinese textbooks after class?
  - If yes, what, why, and how did you read?
  - Did you have any difficulties in doing so?
  - Do you think there is any connection between reading in class and outside school? Why do you think there was such connection or there was not such connection?
  - Did you experience any change in your reading practice compared with before going to school? Why did you or why didn't you change?
  - When did you start learning to write?
  - What was the writing class like?
  - What did you usually write about?
- IV. Learning to read and write in L2 at school and L2 reading outside school
- When did you start learning English?
  - What was the English class like at school?
  - Did you read anything in English except textbooks?
  - If yes, what, why and how did you read?
  - What difficulties did you have in reading English if there was any?
  - Do you think there was any connection between reading in class and outside school?
  - Why do you think there was or was not such connection?
  - When did you start learning to write in English?
  - What was the writing class like?
  - What did you usually write about?



- V. Academic and non-academic reading in both L1 and L2 at university
- What were English classes like at university?
  - Did you read anything in English at that time?
  - What, why and how did you read?
  - Did you have any difficulties in reading in English?
  - Did you read anything academic in Chinese except textbooks?
  - If yes, what, why and how did you read?
  - Did you read anything non-academic in Chinese?
  - If yes, what, why and how did you read?
  - Did you see any influence of your reading habits in Chinese on your reading in English?
  - If yes, what was it? If no, why do you think there was no influence?
  - Did you have English writing class?
  - If yes, what was it like?
  - What did you usually write in English?
- (Questions in sections I-V were intended to answer RQ1-- *What were the main reading practices of the subjects before they came to the UK?* and RQ2-- *What aspects in the context (in terms of the activity system model) have played what role in the shaping of the subjects' reading practices prior to their arrival in the UK?*)
- VI. Reading in L1 and L2 in the UK
- What do you usually read (academic and non-academic) every day (e.g. in the past 24 hours)?
  - Why, where, and how do you read them?
  - What do you usually do after reading something (e.g. whether there may be any following actions: both thinking and doing)?
  - Do you think there is any change in what you read every day in the UK compared to that in China?
  - If yes, what is the change and why?
- VII. General information about the courses
- What courses are you taking in the first term?
  - Which are compulsory and which are elective?
  - How are they conducted?
  - How are you going to be assessed?
  - What are the reading requirements for the courses you are taking in the first term?
- VIII. Questions about the details of one piece of reading
- Could you show me something you have read recently for a particular course?
  - How typical is this piece of reading in relation to what you have to read?
  - Why did you choose to read this particular one?
  - Where and how did you get hold of it (e.g. library, websites, handouts, etc.)?

- Where did you read it?
- How did you read it (e.g. whether read on your own or with others as a group, how to take notes, how to mark the text, what language to use for taking notes or marking, how to use the notes, etc.)?
- How long did it take for you to finish?
- What did you do with it after reading it?
- What is difficult in it and why is it difficult, if there is anything difficult?
- What is easy in it, and why is it easy?
- What do you remember/learn from the text?

(Questions in sections VI-VIII were intended to answer RQ3-- *What are the main kinds of academic reading practices which the students experience in a UK university setting?* and RQ4-- *What are the features of the activity system of a master's programme in a UK university in comparison with and in contrast to the activity system that the subjects used to belong to in China?*)

Is there anything else you would like to add to what have been said? Is there any question you would like to ask me?

## Appendix 2: Questions for the second interviews with students

- I. General questions about the assignment and reading
- What is the topic of your assignment?
  - How and why do you choose your topic?
  - What do you need to read for this assignment?
  - How do you decide what you should read?
  - Where can you find what you need to read?
  - How much have you finished reading so far?
  - Where do you usually read for your assignment?
  - How do you usually read for the purpose of writing assignment?
- II. Questions about the details of one piece of reading
- Could you show me one piece of reading you have done recently for writing this assignment?
  - How typical is this piece of reading in what you have to read?
  - Why did you choose to read this particular one?
  - Where and how did you get hold of it (e.g. library, websites, handouts, etc.)?
  - Where did you read it?
  - How did you read it (e.g. whether read on your own or with others as a group, how to take notes, how to mark the text, what language to use for taking notes or marking, how to use the notes, etc.)?
  - How long did it take for you to finish?
  - What did you do with it after reading it?
  - How are you going to use it in your assignment?
  - What is difficult in it and why is it difficult, if there is anything difficult?
  - What is easy in it, and why is it easy?
  - What do you remember/learn from the text?

(These questions were intended to answer RQ5-- *What literacy experiences did the subjects actually have while reading for writing assignments within the context of their current activity systems?* and RQ6-- *What factors appear to have led to the subjects having such experiences?*).

### **Appendix 3: Questions for the third interviews with students**

- Have you read the marking criteria carefully before you started writing?
- What do you think is the strength of your essay before you got the tutor's feedback?
- What do you think is the weakness of your essay before you got the tutor's feedback?
- How did you estimate your mark (if you ever did so)?
- Are you satisfied with your mark, and why?

Go through the tutor's comments with the interviewee:

- What do you agree with concerning the tutor's overall comments, why?
- What do you disagree with concerning the tutor's overall comments, why?
- What do you agree with concerning the tutor's textual/more detailed comments, why?
- What do you disagree with concerning the tutor's textual comments, why?
- In what ways are the tutor's comments useful for your future essays?
- What are you going to do while writing your next essay, especially in relation to reading?

(These questions were also intended to answer RQ5 and RQ6).

## **Appendix 4: Questions for the first interviews with subject tutors**

- What course(s) do you teach?
- How do you teach the course?
- What are the reading requirements for the course (e.g. reading list/course book/handouts) and in what language?
- How could the students get hold of the reading materials?
- Do you usually check whether the students read as you require; and if so, how do you do that?
- Do you think your students need any support in their academic reading; what support do they need and why?
- What support can you offer to your students?
- How do you assess your students?
- Why do you choose such a form of assessment?
- Do you specify what kind of reading the students need to do for the assessment? (If yes, in what way? How do you judge whether the students meet your requirement?)
- If you teach both undergraduate and postgraduate, what is the difference between them concerning the reading requirements?

(These questions were also intended to answer RQ3, RQ4, RQ5 and RQ6).

## **Appendix 5: Questions for the second interviews with subject tutors**

**(After marking the students' writings)**

- What is the topic(s) that you teach in this course?
- Are the students' works related to your topic?
- How many pieces of writing have you marked?
- What is good about those writings?
- What needs to be improved in those writings?
- How well have the students done the reading for their writing?
- What do you think about the ways in which students used references in general?
- Repeating the above four questions for the particular student in question.
- Did the reading that the students have done match your expectation?
- What needs to be improved in their reading and/or the ways in which they use the readings in the future?

(These questions were also intended to answer RQ5 and RQ6).

## **Appendix 6: Questions for the interviews with tutors of academic support course**

- What is the idea of running this course?
- Who is attending it?
- Who is teaching it?
- How long does this course last?
- What is covered in it?
- Why do you decide to cover those topics?
- How is it delivered?
- How well do you think this course helps students?
- Have students ever given feedback on this course?
- What kind of feedback have you got?
- What topics are you going to cover in the future (if the course will still be run)?
- Anything else that you think you should have done but did not do, and will do in the future?

(These questions were also intended to answer RQ3, RQ4, RQ5 and RQ6).

## Appendix 7: IER module outline

### Appendix 7: IER module outline

# MA MODULE 801: INTRODUCTION TO EDUCATIONAL RESEARCH AND EVALUATION

## OVERVIEW

This is a core course within the MA programmes offered by the Department of Educational Research. It is also open to other social science and humanities students. Although it will be useful for intending and practising teachers, it is not a professional training course.

The module is designed to satisfy in part the requirements of the ESRC Postgraduate Training Guidelines for Educational Research. In particular this module seeks to provide students with the opportunity to engage with the practice and the principles of educational research, while introducing methodological debates within social research more generally.

## AIM

This module is the department's introduction to educational research and evaluation. The course is designed to combine engagement with social science methodologies, especially those drawn from sociology and psychology, with an insight into the nature of contemporary educational and learning issues.

This module has the dual aim of familiarising students with (a) the available methods of research design, data collection and analysis, and (b) the philosophical underpinnings of research in education.

It aims to provide

- post graduate training within a research culture that reflects the strengths of the department with a research record of international standing.
- An opportunity for students to experience a high quality education in the theory and method of educational research and evaluation.

## OUTCOMES

On successful completion of this module, students will have the necessary knowledge, understanding and skills to



1. position educational research and evaluation in a theoretical and organisational context
2. understand the relationship between professional problem solving and the critical analysis of research and evaluation processes.
3. identify and critically assess a range of social research design, method and analysis
4. identify a research problem and design an appropriate research methodology
5. consider and discuss the philosophical assumptions underlying different methods of empirical enquiry
6. recognize and respond appropriately to ethical issues raised by a research context
7. critically assess the validity, reliability and generalizability of a given research study
8. demonstrate practical competence in generating and/or manipulating research data

The following table links these outcomes to the assignments required.

Task	O1	O2	O3	O4	O5	O6	O7	O8
<b>ALL STUDENTS:</b>								
Coursework 1: Research proposal	√	√	√	√	√	√	√	
Coursework 2: Practical Data Collection or Analysis Exercise				√		√	√	√
<b>ESRC FUNDED STUDENTS ONLY:</b>								
Coursework 3: Comparative Review	√	√	√		√	√	√	

## OUTLINE SYLLABUS

The module will be taught over ten, two hour sessions. The overall course convenor is Mary Hamilton who will start the course off by teaching the first two sessions. Subsequent sessions are taught by other members of the course team as listed on the front of this handbook. All sessions include a break for tea/coffee in the middle.

Sessions 1 & 2 introduce the course and offer a critical assessment of ways of eliciting data and evidence in research and evaluation activities. General themes and key questions will be introduced which contrast the authority of different types of data by exploring concepts of validity, reliability, representation, generalisability and ethics. Sessions 3-8 and 10 deal with particular research methods that you may encounter in the educational research literature and wish to use in your own work. Session 9 is a practical session in which you will be asked to compare two research papers.

The themes introduced at the beginning of the course will be picked up throughout in relation to each specific method and issues to do with analysis of the different kinds of data generated by these methods will also be discussed. The module also includes guidance on the assignments. In sessions 8 & 10 you will be introduced to statistics and quantitative data analysis. A separate course is available for those wishing to gain further experience of quantitative analysis using SPSS. This can either be pursued as a self-study option, or through the Centre for Applied Statistics at Lancaster. Details are available from the module convenor.

## **TEACHING STYLES AND LEARNER ACTIVITIES**

The teaching style will depend on the topic; however, the module will employ the following range of teacher actions

- Providing introductory, synthesising accounts of key issues in lecturing format
- The provision of case histories, examples and approaches
- The orchestration of debates and discussions around stimulus material
- The formation of learner groups to address tasks or the critical assessment of cases and examples
- The facilitation of feedback or plenary activity to synthesise general learning points

Learner activities will include

- Note taking from short introductory lectures
- Notes on papers and stimulus material ready for sessions
- Individual and group preparation of presentations
- Whole and small group discussions
- Individual research and reading
- Small-scale practical data collection and analysis activities

## Appendix 8: IER module assessment details

### Appendix 8: IER module assessment details

#### **ASSESSMENT**

Assessment will involve two pieces of course work:

- (1) a research proposal which makes explicit reference to the rationale for the method chosen (2,000 words) and
- (2) a practical exercise using a particular chosen methodology which differs from those which the student will undertake elsewhere in the programme (2,000 words).

A further assignment is required from ESRC-funded students only:

- (3) a comparative review of two research reports or journal articles which makes explicit reference to methodological and theoretical issues (2,000 words).

Sample assignments from previous years will be available for you to look at in the beginning sessions of the course.

**Assignment 1:** (*All students*) A short research proposal containing the following elements [2000 words]

A statement of a clearly focused research question  
 Theoretical framework  
 Indicative literature  
 Method of data collection and rationale for choice of method  
 A statement of uses of the research

**Assignment 2:** (*All students*) A piece of small-scale data collection based on one of the methods you have been introduced to on this course [2000 words]. You will be able to select from the following:

Questionnaire  
 Observation  
 Interviewing

**SPSS**

You will be given further instructions on this assignment during the course.

**Assignment 3:** (*ESRC-funded students only*) A comparative examination of two research reports/journal articles to include the following elements [2000 words]

A brief description of the research aims and main findings  
 A description of the method of data collection  
 A comparative analysis of the strengths and weaknesses of the method in each report.

This assignment will be described in detail in Session 9 of the course.

The specifications for the coursework assignments and details of the criteria we use in marking them are given in the MA Handbook you received at the beginning of the course.

Your work must be in good English and we prefer plain, direct writing. You may write in the first person if this feels appropriate to you. If you hand in a piece of work in poor English we will concentrate on whether what you say is easily understood. If so, we will mark it but return it to you for revision.

Please respect the length limits for each assignment. If a piece is too long it is likely to be returned and you will be required to shorten it to the right length before it is marked.

You should use common academic conventions for references as explained in detail in the MA Handbook. You may wish to visit

[http://www.bournemouth.ac.uk/library2/html/harvard\\_system.html](http://www.bournemouth.ac.uk/library2/html/harvard_system.html)

to refresh your memory about the correct use of the Harvard referencing system. If you hand in a piece of work with incomplete references, we will mark it but return it to you for revision. You will not receive the mark or the comment sheet until you have revised the references.

We ensure that our marking is consistent by having second markers review the first markers' work and adjusting marks, when appropriate, in the light of this second opinion. Details of the procedures for marking, and our marking criteria for assignments are given in the MA Handbook.

If you think that the comments on your essay suggest that we have misunderstood your essay, or need to be corrected, then get in touch to sort it out. We lay no claim to infallibility.

### **LATE SUBMISSION OF WORK.**

Departmental policy applies. See the MA Handbook.

### **What you should expect of tutors**

We will be punctual, prepared and knowledgeable about the topic in general. We will respond promptly to *email* enquiries and requests for meetings. If you run into difficulties, we will explore with you ways of stopping them from jeopardising your performance on this course. When work is submitted on time, it will be ready for you to collect from the MA Secretary within four weeks. Work that comes in early or late will be marked as soon as we have time available to do it. All assignments will be returned with comments that indicate ways of improving future pieces of work.

### **What we expect of you**

We expect you to take responsibility for working hard enough to achieve the grades you hope to get for this course. On that assumption, although we will monitor your attendance, preparation and performance, we will not normally harass or chivvy you. We expect you to take responsibility for the consequences of absence, poor workload planning, inadequate preparation or insufficient application. You must attend at least 80% of the sessions on the course and you should prepare for them appropriately, as indicated in advance by tutors. You should talk to the course convenor if you hit difficulties and ask for advice. We also value feedback from you about the course and suggestions for improving it.

### **Special circumstances.**

Some of you will, unhappily, run into problems that impede your work. If you need an extension for a course assignment you should contact the MA Secretary, Lauren Proctor, not the module tutor. However, if you wish the Board of Examiners to take account of your case, you must inform the MA tutor, Paul Ashwin and ensure that we have all necessary documentation before the Board meets.

## Module 801 Introduction to Educational Research and Evaluation

Nov. / 1st now

### Assignment 1: Due in on Monday November 21<sup>st</sup>.

You are asked to write a short research proposal (2,000 words) containing the following elements (explained in more detail below):

- use this headings to organize your proposal*
- A statement of a research problem (something that interests you)*
  - Theoretical aims — (way that you want to approach the question)*
  - Indicative literature — (identify kinds of reading.)*
  - Research questions*
  - Research design — what you plan to do / the way to conduct*
  - Method of data collection*
  - A statement of use and dissemination*

This assignment gives you the opportunity to draw on what you have learned from the module about research methodology and to put it to use in a practical way by designing a piece of research that you might carry out later. When you start thinking about doing a small-scale research study or planning your MA dissertation you will need to write a proposal that has the same format as this assignment. You are free to choose any topic for the assignment proposal. However, if you already have an idea of a topic you would like to pursue later in the MA course, then it is a good idea to use this assignment as an opportunity to think about how to translate it into a practical research study.

### Elements of a Research Proposal

#### 1. *A statement of the research problem*

This is an introduction that explains what the research going to be about and why it is worth doing it. It is often useful to phrase "the problem" as a question that you want to answer, or a puzzle that needs to be solved (perhaps arising from your professional practice in education). This bit is deceptively difficult: identifying a "researchable" question is half the battle in doing high quality educational research and evaluation, so don't get put off if you find yourself spending longer than you expected on getting it right.

#### 2. *Theoretical aims*

This will come from your reading in the topic area (e.g. why are boys under-performing in literacy?) and should *briefly* outline the framework you are using to understand the topic (e.g. psychological theories about motivation; sociological debates about cultural practices of literacy; feminist perspectives on education). You should, therefore, refer to one or two key readings that signal the framework you are starting from.

#### 3. *Indicative literature*

This element develops on from the previous one and is often combined with it. Here you will briefly review and evaluate any existing studies that touch on the topic of your research proposal. If you are aware of debates and controversies between different approaches to the topic, then you should mention them here. If there are

debates about which methodologies are appropriate for exploring this topic, then mention these too.

#### **4. Research questions**

This should be a list of up to 5 questions that elaborate on your main research problem. They should be questions that you will aim to answer from the evidence you gather in your research study. They should therefore link with your overall aim and with the data collection that you plan to carry out. Keep checking between sections in your proposal asking yourself: will the data I plan to collect actually give me the evidence I need to answer this question? (e.g. if one of your research questions is 'what kinds of texts do boys read?' then you need to choose a method of data collection that will enable you to find this out (observation, or perhaps self-report in interviews or questionnaires).

#### **5. Research design**

This is a short description of what you plan to do which gives details of the context and sample (e.g. two contrasting schools, two classes in each); timescale; how you will gain access to research participants; ethical issues and issues to do with validity, reliability and generalisability. The aim of this section is to enable the reader to visualise what you will actually do and how, and how you will deal with any obvious practical and ethical problems that might arise.

#### **6. Method of data collection**

This gives additional details about the actual method(s) you plan to use. Be as specific as you can (for example, include numbers of interviews or questionnaires that you plan to carry out). Include a short statement of why you think the data collection methods you have chosen are suitable and why you have rejected others.

#### **7. A statement of use and dissemination**

What will you do with your findings once you have them? Who will get to find out about your research and how will you communicate with them (through writing or oral presentation? Make a video?). What practical impact do you expect your research to have?

## Appendix 9: Feedback on E1's IER assignment

Appendix 9: Feedback on E1's IER assignment

**1<sup>st</sup> Marker**

### Department of Educational Research MA in Education Coursework Feedback Sheet

STUDENTS NAME		MODULE	801
1 <sup>st</sup> Marker		Submitted	
Agreed Mark	67%	Date marked	29/11/04
<input type="checkbox"/> this mark is subject to confirmation at the MA Board of Studies			
<input type="checkbox"/> retain your coursework until your mark is confirmed by the Postgraduate Registry			

#### Comments to help your work for the future.

Overall this is a an accomplished assignment. The proposal begins with a useful review of the literature on stress for both home and international students and argues that this area has not been the subject of a specifically focused inquiry before. The design and scope of the research is about right and I would classify the work as a scoping study in which the key variables might be refined and developed. It would also stand in its own right. I would like to know the extent to which the original instrument had been adapted by Liu for the purposes of this work.

#### Comments on this piece of work:

1. Need to include a contextualising discussion here before moving into specifics. E.g in what context does this hold?
2. This is a good discussion of the focus for the study
3. You may also need to be aware of the types of stress that seem to be experienced by different groups not just levels.
4. I am not sure this is quite as straight forward as you suggest i.e. stress is complex.
5. Subjectivity is more or less always present in research instruments if you mean 'bias'. In questionnaires it is present in the order of questions, the choice of questions, the weighting of variables etc.
- 5a Make it clear that the instrument is in the appendix and the extent to which it has been adapted.
6. I would classify this as a scoping study



## Appendix 10: Feedback on E2's IER assignment

Appendix 10: Feedback on E2's IER assignment

### Department of Educational Research MA in Education Coursework Feedback Sheet

STUDENTS NAME		MODULE	EDS 801
1 <sup>st</sup> Marker		Submitted	15/11/04
Agreed Mark	60%	Date marked	3/12/04
<input type="checkbox"/> This mark is subject to confirmation at the MA Board of Studies <input type="checkbox"/> Retain your coursework until your mark is confirmed by the Postgraduate Registry			

Comments to help your work for the future.

Your English is pretty good, and should improve further with practice.

While your referencing is generally good, there is the odd blooper, probably caused by lack of familiarity: e.g. there is no such author as 'Judith, B' (p. 11).

With your questionnaire, take care not to let individual questions run over more than one page.

I presume you are going to administer your questionnaire in Chinese. You should, therefore, give some consideration to issues connected with translation and cross-cultural understanding.

There is no such date as February 30<sup>th</sup>!

Comments on this piece of work:

A good piece of work. You've done a useful range of reading, and have hit on professional identity as an appropriate organising concept.

You've devised a sensible strategy for sampling, building on your existing range of contacts. I also liked the way you sought to draw your questions out of the literature. I wasn't so sure how closely some of them were linked to the issues you wanted to research, but they should provide useful data related to them.

I particularly liked your draft covering letters, which struck me as likely to persuade folk to answer what is a moderately long questionnaire. Enclosing an evaluation form as well might be going just a little too far though!

What evidence do you have for believing that questionnaires produce more truthful and reliable answers than interviews (p. 7)?

## Appendix 11: TLA module outline

### Appendix 11: TLA module outline

#### MA Programme

### Understanding Learning, Teaching and Assessment: Psychological Perspectives

#### Audience

This module is provided within the MA programmes offered by the Department of Educational Research. It is planned to be relevant to post-graduate students with a good interest in education as well as useful for educational practitioners (teachers, lecturers). It is open to all post-graduate students in the Department along with other social science and humanities students, especially those with an interest in psychological perspectives applied to education. Although it will be useful for intending and in-service teachers' professional development, it is not a professional training course.

#### Overview

The module is designed to combine engagement with social science theories, especially with those drawn from psychology, with an insight into teaching and learning in formal settings such as the classroom and school and also in informal settings such as the home and workplace.

#### Objectives

By the end of the module, you will have:

1. acquired a working knowledge of ideas and evidence relevant to a range of issues covered by the general and specific areas of the module
2. developed an analytical and critical understanding of a select number of primary source texts
3. demonstrated your capacity to express your knowledge and understanding in written projects, including both assessed and non-assessed coursework
4. begun to construct a research-based understanding of teaching and learning allied to common-sense and/or your professional expertise
5. acquired a working understanding of ways of applying your research-based understanding to formal and/or informal settings in education

The two pieces of coursework will engage you with most, but not necessarily all, of these objectives (your choice of assignments allows you to concentrate on some objectives). The teaching and learning arrangements will together address all of the objectives.

### **Our approach to teaching and learning**

Teaching and learning are organised around a mix of tutor presentations, seminar and group-problem working, discussion and associated activities, individual and shared readings. Work preparing for and then writing the assignment makes a substantial contribution to your overall learning. Tutors expect to give individual advice on this part of your work. As befits postgraduates, it is up to you to identify the tutor most able to help with a particular problem, make arrangements to discuss it and then keep contact going until you feel that you are able to handle the problem by yourself.

The taught sessions of this module aim to provide you with a framework to guide your learning. However, a large part of your learning will occur outside the class when you undertake your own reading and research. We have provided a list of readings relating to each topic covered on the module, but these lists cover only a fraction of the material available in these areas. Please do not feel constrained by these lists - it is recommended that you read as broadly as possible. Below are some of the databases that you should use to find other materials relevant to the course. More detailed information on all of these facilities is available in the library.

**ERIC** (Educational Resources Information Centre) - this database has a strong emphasis on American educational documents, providing article reference and abstracts.

**British Education Index** - the major database in this subject area, indexing a wide variety of British education journals.

**PsycINFO** - Comprehensive psychology database, good for child and educational psychology.

**ASSIA** (Applied Social Sciences Index and Abstracts) - large sociology database, useful for areas of relevance to education, including training, community education, careers, etc. Provides article references with abstract.

**International ERIC** - Database containing the British Education Index (see above) and the Australian Education Index.

**IBSS** (International Bibliography of the Social Sciences) - a large social sciences database, covering many areas potentially of relevance to educational researchers

**Social Science Citation Index** - indexes over 1700 social science journals; with good coverage of education topics.

For information about how to access these databases, visit the web site at <http://libweb.lancs.ac.uk/G65.htm>

## The Module At A Glance

Week	Date	Topic	Lead Tutor(s)
Please check the detailed weekly entries in the pages that follow for reading that you should do in advance of each session and any instructions that you should follow in your preparation. Readings will be available for collection from the MA office.			
1	7/10/04	Introduction to the module Understanding learning - theories and assumptions The socio-cultural context of teaching and learning	
2	14/10/04	Theories of effective instruction 1	
3	21/10/04	Theories of effective instruction 2	
4	28/10/04	Theory and practice - classroom interaction in detail	
5	4/11/04	The social context - learning in groups and friendship pairs	
6	11/11/04	Training talk - improving learning in groups and individuals - practice, policy and experimental study	
7	18/11/04	Assessing learning - theory and practice	
8	25/11/04	Academic motivation 1	
9	2/12/04	Academic motivation 2	
10	9/12/04	Academic motivation 3	

28 <sup>th</sup> February 2005	<p><b>Final coursework deadline</b></p> <p>Assessment is by means of two closely linked pieces of coursework. The first is a short critical commentary of 1000 words which acts as a stage towards the second, which is a longer essay of approximately 3000 words. You can hand both pieces in together by this final deadline or alternatively you can hand the first piece in earlier and get feedback on this piece before progressing to the second. The first assignment is a review of a target paper which we have chosen because it provides a good basis for the essay question that then comprises the second assessment. More details on page 12.</p> <p><b>Please note the word limits for these pieces!</b></p>
--------------------------------	---

## Appendix 12: TLA module assessment details

### Appendix 12: TLA module assessment details

#### Assessment details

This module is assessed by two pieces of coursework. Coursework [A] is a review task which has a word limit of 1,000 words and is worth 25% of the total mark for this module. Coursework [B] is related to coursework [A], but is longer (3,000 words) and is worth 75% of the total mark for this module.

You should select ONE of the two questions below and answer both part [A] and part [B] of that question. You are welcome to complete task [A] first and gain feedback on your work, followed by task [B]. Alternatively, you are welcome to submit both tasks [A] and [B] together by the module deadline (28th February 2004).

#### Question 1

##### Task [A] Review Task (25%)

Mercer, N. and Fisher, E. (1992) 'How do teachers help children to learn? An analysis of teachers' interventions in computer-based activities' An edited version of this article, which originally appeared in *Learning and Instruction*, vol. 2, 1992 can be found in D. Faulkner, K. Littleton, and M. Woodhead, (1998) (eds) *Learning Relationships in the Classroom*. London: Routledge.

Critically evaluate Mercer and Fisher's arguments for the advantages and limitations of a neo-Vygotskian approach to teaching and learning processes in the classroom. How far do you agree with their views? (Word length: 1,000)

##### Task [B] (75%)

"...to provide assistance in the ZPD, the assistor must be in close touch with the learner's relationship to the task. Sensitive and accurate assistance that challenges but does not dismay the learner cannot be achieved in the absence of information" (Tharp and Gallimore, 1991, p. 57)

Write an essay of 3,000 words focusing on the questions: What are the main barriers for the teacher in acquiring the information about their learners that Tharp and Gallimore identify as necessary for the provision of 'sensitive and accurate assistance' through the ZPD? Can these be overcome?

In answering this question you are encouraged to draw on the critical evaluation you undertook for assignment 1. In this second assignment you are now required to broaden your range of reading; exploring what others have said about Vygotsky's contribution to the theory and practice of 'effective instruction' and the concept of the ZPD, and issues in assessment.

Reference: Tharp, R. and Gallimore, R. (1991) 'A theory of teaching as assisted performance' in: P. Light, S. Sheldon and M. Woodhead (Eds) *Learning to Think*. London: Routledge.

## Question 2

### Task [A] Review Task (25%)

Hidi, S. and J. M. Harackiewicz (2000). "Motivating the academically unmotivated: A critical issue for the 21st century." *Review of Educational Research* 70(2): 151-179. Write a review (1,000 words) of Hidi and Harackiewicz's paper. The review should be a summary of the key points of the paper – what is the main argument and how convincing is it?

### Task [B] (75%)

Write a 3,000 word essay to answer the question: how can research on motivation be used by teachers to inform their classroom practice?

Use your review of the Hidi and Harackiewicz article as the starting point for responding to this question. However, you will need to broaden your range of reading in your response and you will need to consider the ways in which the theories may be translated into practice. There are too many theoretical approaches to motivation for it to be possible to sensibly cover them all here, so you will also need to select your theoretical point of focus, and to argue for your choice.

### **Assessment Marking criteria**

The *literature review/discussion* criteria, printed in the MA Handbook will be used unless you agree with the tutor advising you on a piece of work that others should be used. These default criteria are printed here for your convenience.

### **PASS**

An outline of the problem will be given, which will be associated with an account of the way in which this problem has been conceptualised, investigated and discussed by other people in the existing literature.

A pass essay should consider some of the positions which you reject and explain why these positions should be rejected. Similarly, positions which can be supported should be identified, or, in some cases, you may wish to suggest directions for future study. Frequently, practical as well as general implications will be discussed.

### FAIL

These essays will incline to description at the expense of evaluation and criticism. Sometimes this will be because a suitable title has not been agreed.

There will be some evaluation and criticism of the literature but it is likely to have characteristics of the sort described under the "book/article review" heading in the MA Handbook.

### DISTINCTION

This category of work is distinguished from pass standard work by the presence of features similar to those described under the "book/article review" heading.

**Late submission of work.**

Departmental policy applies. See the *MA Handbook*.

#### Special circumstances.

Some of you will, unhappily, run into problems that impede your work. Only you can decide whether to tell us (in general terms, please) about them. However, if you wish the Board of Examiners to have them in mind, you must inform the MA Director, Paul Ashwin, and ensure that we have all necessary documentation before the Board meets.

## Appendix 13: Feedback on E1's TLA assignments

---

### Appendix 13: Feedback on E1's TLA assignments

*Department of Educational Research  
MA in Education - Feedback*

*June 14, 2005*

**Course member:**

**Module:**

**First marker:**

**Second marker:**

You have produced a very clear and concise account of the main concerns of the target paper. Given the length and complexity of the target paper this is, in itself, a fairly considerable achievement and one for which you deserve full credit.

It is however only in the final, brief paragraph that you begin to analyse the nature of the possible contribution of this paper to our understanding of the nature of classroom motivation. Even here you do not really address the extent to which the authors have been able to say anything substantial and useful about the critical issue of improving the motivation of poorly motivated students.

In the future therefore you need to attend more to developing a critical analysis of the paper and to devote less of the space available to you to descriptive accounts of the paper (irrespective of how good these may be).

**Comments on this piece of work:**

1. it is not clear, to me at least, what you mean by "unilateral" in this context.
2. Try to be clear as to which aspect of their argument you are referring to here. If their argument is that more should be begun to draw together research into interest and motivational goals then the lack of such research cannot really be said to make their argument less convincing.

**Overall grade: 57**

57%



Department of Educational Research  
MA in Education - Feedback

June 14, 2005

**Course member:**

**Module:** Unit 2

**First marker:**

**Second marker:**

**1<sup>st</sup> Marker Comments**

This continues in very much the same vein as your first assignment. The choice of rewards systems as a focus for the essay is a good and appropriate one. The summaries that you have provided certainly succeed in drawing attention to some of the principal issues.

As with the first assignment however, and as indicated in my specific comments below, you have not given sufficient attention to the theoretical background to this work. As such it is difficult to see how the research on rewards systems is related to various conceptualizations of the nature of motivation itself. As such it does not fully address the concerns of the title.

More to the point, I would argue that it is through the development of theoretical explanations as to why rewards may "work" in some cases and not in others that teachers will be able to develop their own strategies in relation to the use of rewards in any given classroom situation. It is this aspect of the work that you need to give further attention to.

**Comments on this piece of work:**

1. I am not so sure that you have provided us with a theoretical framework. You have provided a useful account of the summary findings concerning the claims and counterclaims of the potential effects of different types of rewards upon motivation. However you have not provided very much by the way of attempted theoretical explanations for these different effects. It is possible to argue that the theory underlying the findings is potentially of greater benefit when it comes to consideration of classroom publications, than the findings themselves. You may of course have more to say on this yourself as the essay develops.

**Overall grade: 62**

## Appendix 14: Feedback on E2's TLA assignments

### Appendix 14: Feedback on E2's TLA assignments

发件人 :  |  |  |  收件箱  
 发送 :  
 收件人 :  
 主题 : my assignment

@ 附件 : Task(1).doc (0.04 MB), Neo.doc (0.07 MB)

comments of task 1:

this was very descriptive but also omitted a lot of important explanatory detail. you do get into some criticism at the end of the essay and you needed to draw this out more. i think you were right to focus on the sequences that Mercer and Fisher quote in support of their overall argument. one of the major issues seems to me to be the fact that they could not be sure about the outcomes of the sequences that they tell us about and this point seems to be worth pursuing. they also make some important points which you overlooked in your critique, for example the point at the bottom of p27 where they addressed issues of the difficulties large classes present for of the application of neo-vygotskian theory.

comments of task 2:

you have made a good effort to deal with some difficult material here but there are some problems in your writing which makes it hard for the reader to follow what you want to say. the major issue is that you need to structure your writing clearly and focus on how to organize your essay. using more headings might help you. it would be useful for instance if you were to start your essay with the quote that you are given to base your essay on. then you could have clarified for your reader what the basic issue is that you were going to be. if you do this then it helps your reader to understand your paper and also makes it easier for you to structure your essay. be very careful to indicate when you are quoting from another writer and also make sure that if you use quotations you comment on them rather than using them as a substitute for explanation of your own.

that's all. i am wondering if the marker agrees with your requirement.

## Appendix 15: Marking criteria (Faculty of Arts and Social Sciences)

### Appendix 15: Marking criteria (Faculty of Arts and Social Sciences)

#### FACULTY MARKING/GRADE CRITERIA FOR MASTERS LEVEL ASSIGNMENTS

These guidelines are intended to spell out the criteria that are used to assess written work. The criteria show the features we expect to see in work of a given mark or grade. To achieve a given grade, students do not have to have met all the criteria listed; however, they must have demonstrated a preponderance of those qualities in their work. Although modes of assessment vary (essays, dissertations, other forms of written output) the principles by which markers arrive at their judgements remain the same. Below is a list of aspects of students' work which may be taken into account during assessment, as appropriate.

- Relevance of material in the essay to the title of the assignment.
- Relevance to the content of the course.
- Understanding of issues or problems under discussion.
- Knowledge and understanding of relevant readings.
- Critical discussion of relevant readings.
- Use of suitable data.
- Clarity and depth in the analysis of theory, data and issues under discussion.
- Coherence of argument.
- Clarity and relevance of introduction and conclusion.
- Clarity and precision of expression.
- Use of appropriate and consistent conventions for referring to other people's work.
- Clarity of presentation (layout, including use of paragraphs and tables, for example).
- Clarity of writing including grammar, punctuation, spelling and sentence construction.
- Compliance with published regulations on the completion of assessed work by the coursework deadline

#### **Criteria for the award of marks 70 + (distinction)**

A piece of written work in the 70+ range is one of exceptional quality, requiring a high level of conceptual ability and an extremely thorough and conscientious approach to study. Work in this range will clearly demonstrate the capacity to proceed to a higher research degree. It is distinguished by:

#### **Argument**

- A clearly expressed and convincing argument which is used to develop a coherent and logical framework within which to answer the question or address the topic, and which is well grounded in existing theory and research, leading to a reasoned conclusion fully supported by the foregoing material.
- A capacity to relate consistently the theoretical and empirical material to the conceptual framework.
- Substantial evidence of independent research.
- The absence of irrelevant or extraneous material.

#### **Understanding**

- A thorough understanding of the topic and its implications.

- A clear and consistent focus on the issues raised by the question/topic.
- An insightful argument showing signs of originality.

#### Style

- Good grammar, punctuation, spelling and sentence construction.
- Thorough use of conventions of referring to other people's work

#### Marks within this classification may vary due to–

- An original capacity to develop arguments beyond those available in the literature.
- The depth and sophistication of the conceptual argument.
- The level of familiarity with the theoretical and research literature.

#### 60-69 (Good pass)

A piece of written work of a good to very good standard requiring clarity of thought and expression. It will display an ability to handle the relevant literature in an analytical manner. It will be more than a good description of the various theories and/or studies relevant to the question – it will demonstrate a marshalling of relevant information by means of analysis and interpretation. It will not necessarily have a water-tight argument, but it will be clearly structured and its conclusions will not take the reader by surprise. Such a piece of work will generally show less independence of thought and mastery of detail than is required for a mark of 70 or over. There may be some errors or misjudgements with regard to issues which are not central to the argument. Work in this range will normally demonstrate the capacity to proceed to a higher research degree.

It is distinguished by:

#### Argument

- A logical, coherent framework within which to answer the question or address the topic.
- An ability to organise the data in a way that provides a clear and logical answer to, or discussion of, the question/topic.
- A clearly expressed theme or argument developed from a critical consideration of relevant literature.

#### Understanding

- A good understanding of the topic and its implications.
- Familiarity with the relevant literature and empirical data.
- The avoidance of irrelevant or extraneous material.
- Evaluation of competing arguments.
- Conclusion supported by the body of the argument and evidence.
- Some evidence of independent research.
- Avoidance of unsubstantiated assertions.

#### Style

- Good grammar, punctuation, spelling and sentence construction.
- Good use of conventions of referring to other people's work

#### Marks within this category may vary due to–

- The clarity and cogency of the overall argument.
- The level of familiarity with the relevant literature and data.

**50-59 (Pass)**

A piece of written work of a moderate to good standard. It will be descriptively strong. It is distinguished from the 60-69 piece by the level of analysis displayed and by the coherence with which the material is organised. There may be some significant errors, misjudgements or omissions of important details. A mark in this range would not normally demonstrate the capacity to proceed to a higher research degree. It is characterised by:

**Argument**

- o An attempt to answer the question or address the topic,
- o A conclusion not entirely supported by or relevant to the body of the essay.
- o A failure to adequately organise an answer into a coherent whole.

**Understanding**

- o A reasonable understanding of the topic and its implications.
- o A level of empirical knowledge and relevant reading which demonstrates a conscientious attempt to tackle the question/topic.
- o The intrusion of some extraneous material.
- o A failure to grasp at least some relevant points or address some relevant literature.

**Style**

- o Adequate grammar, punctuation, spelling and sentence construction.
- o Referencing that is incomplete or fails to observe some conventions for referring to other people's work.

**Marks within this category may vary due to-**

- o The level of empirical and theoretical knowledge displayed.
- o The seriousness with which an attempt has been made to answer the question or address the topic.
- o The number of major points that have been covered.
- o The coherence of the essay.
- o The degree of unsubstantiated assertion.
- o Written style (grammar, spelling, punctuation and sentence construction).
- o

**40- 49 (Fail - with the possibility of condonation in accordance with the Faculty regulations.)**

A piece of written work in this category shows signs of engagement with the question or topic, but has inadequacies at Master's level. It signals a failure to give sufficient thought to the work in hand, displaying inconsistent argument, unsubstantiated assertions, and a patchy acquaintance with the relevant literature. It may lack a convincing conclusion and it is likely to include significant errors, omissions and misunderstandings. It is characterised by:

**Argument**

- o A failure to order this material so as to provide an adequate answer to the question.
- o An ability to pick out some of the points required for a satisfactory answer.
- o Inadequate conclusion.

**Understanding**

- o Some knowledge of appropriate empirical material.
- o The intrusion of irrelevant material.
- o An inadequate familiarity with relevant literature.

**Marks within this category may vary due to--**

- o The level of empirical knowledge displayed.
- o The extent to which an effort has been made to answer the question or address the topic.
- o Evidence of conscientious effort.
- o The degree of unsubstantiated assertion.
- o Written style (grammar, punctuation, spelling and sentence construction).

**Style**

- o Sub-standard grammar, punctuation, spelling and sentence construction.
- o Inadequate use of conventions of referring to other people's work

**Marks below 40 (Fail - without possibility of condonation.)**

Marks in the 30 - 39 range indicate that the piece of written work is inadequate in every respect with pronounced errors and misunderstandings. It is characterised by:

Some empirical knowledge.

- o Some evidence of study in the area concerned.
- o An inability to develop any but the flimsiest answer to the question.
- o Problematic conclusion.

**Using the full range of marks**

Departments are encouraged to make use of the full range of marks available, including using marks of below 30% and of above 80% where this is appropriate.

# Appendix 16: LM module outline

## Appendix 16: LM module outline

### “Learning to Manage” Booklet 2004

#### Teaching Team

Course Leader: Alessia Contu, Department of Management Learning  
[a.contu@lancaster.ac.uk](mailto:a.contu@lancaster.ac.uk)

Seminar Leaders: Wayne St Amour, Department of Management Learning,  
[stamour@exchange.lancs.ac.uk](mailto:stamour@exchange.lancs.ac.uk)

Simone Novello, Department of Marketing, [s.novello@lancaster.ac.uk](mailto:s.novello@lancaster.ac.uk)

#### Administration

MSc in Management Programme Secretary, Ms Gillian Elsworth at:  
[elsworth@exchange.lancs.ac.uk](mailto:elsworth@exchange.lancs.ac.uk)

#### Outline

This course is designed for an audience approaching the discipline for the first time, but has already mastered analytical skills and studying skills more generally.

Management is a complex and contested arena of praxis so the teaching strategy of the course is to outline for you the main management theories and to sensitise you on issues relevant for making sense of management in today's organisations. Analysis of managerial cases from existing contemporary organisations are used to give a sense of the practical significance of theory in practice. These cases exhibit the diversity in place and feature big multinational corporations as well as small companies across industries.

#### Syllabus

Management learning & Organising: a foundation  
Teams and teamwork  
Decision Making in organisations  
Managing Culture and Corporate Culture  
Managing Motivation  
Managing Strategically  
Ethics and Management  
Leading and Managing  
Influence in organisation: power and politics

## Gender & Diversity

### Desired learning outcomes

At the end of the module you will be able to:

- Understand the complexity and ambiguity of management
- Articulate and explain theories and concepts relevant for making sense of different areas of management: leadership, learning, decision making etc.
- Understand the main issues involved in today's managerial life and possess theoretical tools to make sense and deal with them.

### Teaching Strategy

Our teaching strategy aims to facilitate learning via a mix of tools and methods. We aim to elicit personal enquiry and active exchange amongst you, other students and the teaching team. Participation in a series of activities based on update material is designed to involve you in the discussion of current topics and to a certain extent experience of issues of managerial and organisational life.

#### Lectures:

Lectures identify the main areas of interest and provide conceptual and theoretical tools for understanding management; examples from empirical studies and everyday practice will be provided to illustrate theories and models. Each lecture will provide a list of useful references. Your input during lectures is often required and is appreciated.

#### Seminars:

Teamwork is employed during seminars where learning tools, such as exercises, small projects and case studies of big multinationals to small businesses, are utilised to facilitate your analysis of practical managerial and organisational issues. These seminars often require previous preparation, such as reading the relevant chapter from the textbook and the case studies to be analysed or project preparation in teams. These seminars intend to enable you to articulate your understanding of management theory in practice as well as experience working in teams, henceforth having the opportunity to develop communication, negotiation and leadership skills.



**IMPORTANT:** You will be able to find the material relevant for each seminar in the base room at the beginning of each week.

**Studying tool:**

A textbook comprehensive of theories and interesting cases, which also discusses the ambiguity of managerial life, is utilised as the main source of reference. This is to be considered your main studying tool. However, if you wish to deepen your understanding you are welcomed to engage in further reading, and the lecturer and your seminar leaders will be happy to guide you in your choices if you would wish to do so. Internet sources should be avoided or utilised with extreme care.

The textbook is:

Fulop, L. and Linstead, S. eds (1999) *Management: a critical text*,  
Macmillan: Basingstoke

## Appendix 17: LM module assessment details

---

### Appendix 17: LM module assessment details Assessment

#### MSc in Management

Course work: 60%

2500 words essay to be submitted in paper and electronic format, to be submitted at the MSc in Management base room (A99b) by the 6<sup>th</sup> of December 2004. For enquiries contact Ms Gillian Elsworth at: [elsworth@exchange.lancs.ac.uk](mailto:elsworth@exchange.lancs.ac.uk)

NOTE: No extension will be granted unless medical certification is provided and the rules from your programme handbook are followed.

Exam: 40%

The exam is taking place on the 14<sup>th</sup> of April 2005. You will be presented with a list of questions. You have to choose and answer one question. You are not allowed to bring with you books or notes.

#### Essay questions:

Please choose one from the following essay titles below:

1. What is organisational culture? Is managing culture ever possible?
2. According to Flores and Grey (2000) in 2000, 80% of all Fortune 2000 companies had over half their employees working in teams. Indicate what 'working in teams' means, the complexities of teamwork and why team based work is such a widespread phenomenon.
3. Companies often have ethical guidelines and engage in ethically aware practices. Why should managers be concerned with ethics?
4. How do managers learn about management? Drawing upon the theories discussed during the course, elaborate on the issues involved in managing knowledge.

**IMPORTANT:** For any concern, question or issue related to the course you can contact your lecturer or any of the seminar leaders. We shall be happy to help you and to make sure you can make the best of this learning experience at Lancaster University.

## Essay Tips

a. Your essay should have a clear structure:

**Introduction:**

-What you are saying = general theme + main claims

-Why = motivate your choice

-How you are going to do it = list main arguments in order of presentation

**Main part:** this part approaches and develops the subject of the essay. Make sure you answer the question by creating convincing, clear and rigorous arguments.

**Conclusions:** in this part summarise your claims and main arguments and make explicit the 'added value' your work has created for you and the understanding of the subject

b. Make sure that it is clear and easy to understand and that all the different passages are well connected.... Guide the reader by hand!

c. Polish your essay from mistakes and ask someone else to read it and give you comments/feedback

d. References:

**In-text citations**

When citing references within the text of an assignment, use only the name of the author, followed by the year of publication. *In general, page numbers should be included in all in-text citations:*

The theory was first propounded in 1993 (Hamilton 1994:58) OR The theory was first propounded by Hamilton (1994:58).

When referring to two or more texts by different authors, separate them with a semicolon (;). for example. (Larsen 2000: 82; Malinowski 1999: 19)

Page numbers are compulsory for quotations:

Larsen (1971: 245-6) noted that "many of the facts in this case are incorrect".  
OR "Many of the facts in this case are incorrect" (Larsen 1971: 245-6).

**Bibliography: in alphabetical order**

**Book:**

Surname, name or initials. (year of publication) ed or eds (if edited book by more than one author), *Title (in italics or underlined)*, edition (in not first), publisher: (or comma) place of publication

---

Fulop, L. and Linstead, S. eds (1999) *Management: a critical text*, Macmillan: Basingstoke

Chapter in an edited book:

Surname, name or initials, (year of publication) 'Title'. In: names of editors of book (eds.), *Title of book*. Place: Publisher, Page references.

Snell, R. (1999) 'Managing Ethically'. In: Fulop, L. and Linstead, S. (eds) *Management: a critical text*. Macmillan: Basingstoke, pp. 335-413

Journal Article:

Surname, name or initials, (year of publication), "Title", *Title of the Journal* [in italics or underlined], Vol. Volume Number, no. issue number: (or comma)page numbers of article

Gersick, C. (1988) "Marking time: Predictable transition in task groups", *Academy of Management Journal*, Vol.31, no1:9-41

Internet Sources:

Surname, name or initials, (last update) *Title of website*, Available: URL Internet address (Accessed: Date you accessed the site).

Reul, S. and Deichmann, T. (2001) *The one measure of love is: you can insult the other*, Available :

<http://www.spiked-online.com/Articles/0000002d2C4.htm> (accessed:19 November 2001)

**IMPORTANT:** Remember that plagiarism is prohibited. You should always produce your own work and cite all the references you use in your essay. We do have softwares which enable us to check if what you submit is original.

# Appendix 18: Feedback on M1's LM assignment

Appendix 18: Feedback on M1's LM assignment

**MSc in MANAGEMENT 2004/05**

**MICHAELMAS TERM**

**CORE COURSE: Mngt 501 – LEARNING TO MANAGE**

Student's ID:	
Tutor's name:	
Comments:	<p>This essay presents a complete view on team and teamworking literature as developed in modern organizations. Definition of team, developments phases, roles, etc are fully provided. However, the essay appears as being a collection of points and themes only loosely connected, without offering in other words to the reader an organic view or demonstrating a clear and personal line of thinking deployed by the author throughout the paper. The work could have been improved by using the issues reported in the paper to elaborate a more personal, original and organic view on teamworing in organizations.</p>

**Mark/Grade 50**

## Appendix 19: Feedback on M2's LM assignment

Appendix 19: Feedback on M2's LM assignment

**MSc in MANAGEMENT 2004/05**

**MICHAELMAS TERM**

**CORE COURSE: Mngt 501 – LEARNING TO MANAGE**

Student's ID:	
Tutor's name:	
Comments:	<p>In his essay you refer to relevant literature and make some points that are useful for answering the question.</p> <p>You could have engaged more closely with the issues and the ideas discussed during the course and in your textbook in order to go in depth into the subject matter.</p> <p>The utilisation of internet sources does not help as these sources are unreliable.</p>

Mark/Grade

57

## Appendix 20: EM module outline

### Aims & objectives

The aim of the course is to make students aware of how the micro and macro economic environment can affect business behaviour. In the first part of the course we describe how the market mechanism operates, and evaluate how the nature of competition faced by a business can affect price, output and profit. Emphasis is placed on competition between the few (oligopoly) and so we also discuss strategic business behaviour in some detail. The second part of the course is concerned with the macroeconomic environment, and focuses on the short-run. We consider the determinants and consequences of fluctuations in the business cycle. A substantial part of the course is also devoted to international issues, such as why countries trade, the determination of exchange rates and the role of government in controlling the macro economy. Throughout the course we will focus on issues using case studies, data and empirical evidence.

You are strongly advised to read the recommended textbook and either the Financial Times or the Wall Street Journal.

### Recommended textbook:

Dermot McAleese *Economics for Business*, 3<sup>rd</sup> Edition, Financial Times / Prentice Hall, 2004

### Recommended supplementary texts:

J. Sloman and M. Sutcliffe *Economics for Business*, Financial Times / Prentice Hall, 2001.

C. Mulhearn, H. R. Vane and J. Eden *Economics for Business*, Pelgrave Foundations, 2001.

A. Griffiths and S. Wall *Applied Economics*, Financial Times / Prentice Hall, 2001.

**Web sites:**

You can liven up this course by referring to current policy issues. A lot of information is now available on the Internet and I would strongly recommend you to get acquainted with the sites listed below which produce some very interesting material for this course.

Do please try them.

**1. [www.oecd.org/eco/](http://www.oecd.org/eco/)**

Look for Working Papers and Economic Surveys. The OECD also has a good database for many countries as well as excellent commentary and analysis.

**2. [www.hm-treasury.gov.uk/](http://www.hm-treasury.gov.uk/)**

This is excellent for articles relating to current fiscal and monetary policy in UK. It also provides some excellent macroeconomic data not only for the UK but for all the world's major economies (but excluding China).

**3. [www.bankofengland.co.uk](http://www.bankofengland.co.uk)**

Particularly useful for obtaining up-to-the-minute articles by members of the Monetary Policy Committee (MPC) at the Bank of England and for looking through the MPC's monthly minutes. E.g. go to Publications > Speeches > Speeches by speaker > Dr Sushil Wahdwan (and so on).

**4. Federal Reserve Board (USA)**

This is the Federal Reserve Board's web site. It has a lot of useful articles and up-to-date information and commentary on current events.

<http://www.federalreserve.gov/pubs/feds/>

<http://ideas.uqam.ca/EDIRC/data/frbgvus.html>

**5. OECD <http://www.oecd.org/statistics/#ecostat>**

This site is very useful for historical data and for the latest available data for many countries (including transitional economies and emerging economies).



6. Data sources for a wide range of countries can be found at the following web site:

<http://www.geoinvestor.com/>

**Test yourself on the principles of economics.** To do this you can use the WinEcon programme which is accessible over the intra-net. Go to:

<http://www.lums.lancs.ac.uk/ECON/DEFAULT.HTM> for advice on how to gain access.

This site also provides a range of links to many other useful web sites, including on-line textbooks.

## Appendix 21: EM module assessment details

### MNGT504 Group Projects

You are required to write a group report on one of the topics listed below. The length of the project should be no greater than 5000 words, including appendices. Your project should be written in a report format with clearly identified chapter and section headings. The project should show evidence of:

- an understanding, and demonstration of, relevant economic theory;
- a review of the literature;
- data analysis or case analysis.

### Topics:

1. With the aid of an example of your choice, discuss the origins and causes of the spatial clustering of economic activity. Is spatial clustering good for local and national economic development? What policy implications follow from your analysis?
2. Using a country of your choice, describe the sources of, and trends in, environmental pollution. What policies could, and have, been implemented in that country in an attempt to reduce pollution levels? How successful have these policies been?
3. With reference to a particular sector (e.g. banking, retailing, etc.), describe the market structure, the conduct and performance of firms in that sector and the implications for competition policy.
4. Explain FDI in a country of your choice using Dunning's eclectic framework or other theories of international FDI (provide data on FDI and analyse it from a theoretical perspective).
5. "Free trade is beneficial only if your country is strong enough to be able to stand up to foreign competition" Discuss and evaluate this statement (make use of examples and/or case studies).
6. The Common Agricultural Policy (CAP) is a central policy of the EU. Explain why this is highlighting its role in world trade. Finally, draw your own conclusion as to whether the CAP is a force for good or bad.

## Appendix 22: Feedback on M1's EM assignment

### Appendix 22: Feedback on M1's EM assignment

#### Comments:

An interesting description of recent trends in British supermarket retailing and a good account of each company's position and strategy. My main criticism is that there was not a great deal of economics in the project. You mention several issues, for instance, which deserved to be expanded e.g. barriers to entry (what are they, how do they affect competition?), the regional / spatial element of competition in the sector and how it affects consumer choice at a local level and also the effect of competition on consumer welfare. More on these issues could have been gleaned from the Competition Commission Reports so that your report had more economics. Finally, there was no discussion of the relationship between Supermarkets and farmers, which does raise the issue of monopsonistic power.

Mark/Grade

56

## Appendix 23: Feedback on M2's EM assignment

Appendix 23: Feedback on M2's EM assignment

MSc in MANAGEMENT 2004/05

MICHAELMAS TERM

CORE MODULE: Mngt 504 Economics for Managers

Group Report

Group number:	
Tutor's name:	
Comments:	<p>The essay does not offer much on empirical studies on free trad. references like lots of web sites. It mentions researcher such as Krugman, Stiglitz why not look at some of their work!!! In term of structure table of contents, appendices to show analyses of data</p>

Mark/Grade

62

## Appendix 24: Marking criteria (Management School)

### Appendix 24: Marking criteria (Management School)

MARKING CRITERIA		
<i>These guidelines are used in marking both coursework and examination answers:</i>		
FIRST CLASS	(a) Accurate and complete demonstrating understanding in depth and draws upon extensive reading of the source of the lecture material. Well ordered, using good English, appropriate examples and plenty of illustrative data.	70-79%
	(b) In addition, evidence of extensive reading of sources given by lecturer but extending the breadth of the lecture material.	80-89%
	(c) In addition, original perspectives or insights, argued logically.	90-100%
UPPER SECOND CLASS	(d) Comprehensive, although not complete. Showing understanding based on an ability to marshal information and to support arguments with appropriate examples. Good English. Some pieces of information or examples go beyond the lecture material in either depth or breadth.	65-69%
	(e) As (d) but either occasionally lacking accuracy or with few examples.	60-64%
LOWER SECOND CLASS	(f) Concise but accurate. Based largely on lecture material. Information presented clearly but lacking any originality	55-59%
	(g) As (f) but with occasional lapses of accuracy or logic	50-54%
THIRD CLASS	(h) Answer incomplete, with lapses in accuracy and logic. Examples few or not very relevant. Some evidence of knowledge and understanding of the subject.	45-49%
	(i) As (h) but with serious omissions. Some sound knowledge. Presentation poor. Examples inadequate.	40-44%
PASS	(j) Serious omissions or major errors, though some material relevant to the question. Evidence that the question has been understood in part at least.	35-39%
FAIL	(k) Inadequate with no substance or scientific understanding but with vague general knowledge relevant to the question. Some key words or phrases.	30-34%
	(l) Rudimentary knowledge of the subject area. Even at this level, errors serious and fundamental.	20-29%
	(m) Little hint of any knowledge. May be an answer to the "wrong" question.	10-19%
	(n) No knowledge relevant to the question but the candidate has made some effort.	1-9%
	(o) Nothing written.	0%

## **Appendix 25: Questions for the first interviews with students (pilot study)**

The general purpose of conducting interviews is to investigate difficulties that Chinese students think they have in reading English in both educational and non-educational settings, and why they think they would experience such difficulties. As I would consider reading or literacy practices in a broader sense, as social practice, I would like to see how it is influenced by people around and by the social contexts.

Therefore, I would like to find out their family background, their pre-school reading, their reading at school/university and in non-educational settings, and their reading in L2. I would sequence the questions according to time order in general.

### **A loose structure of the interview:**

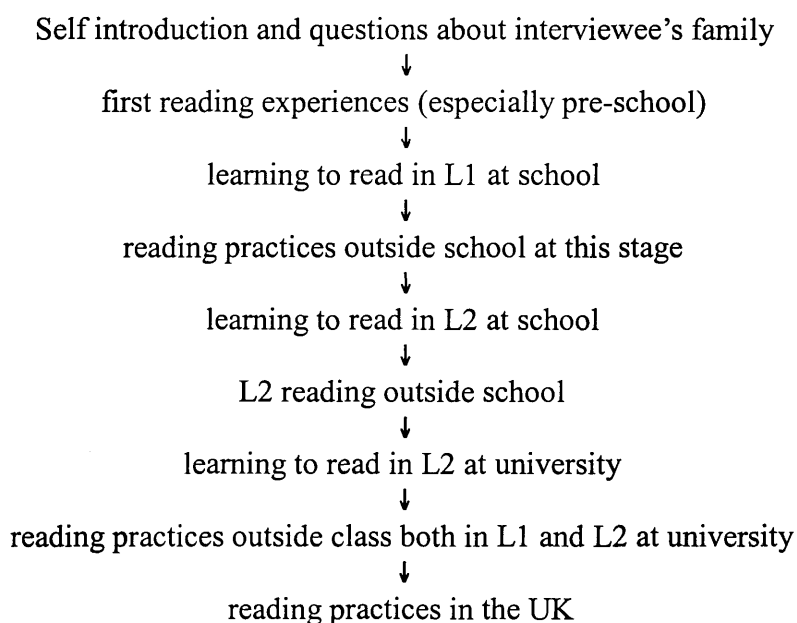

### **More specific questions:**

--Where are you from? What do your parents do? Are there any other members in your family? Where did you grow up? Where did you go to school? From which university did you graduate?

--Do you remember when you start reading? What, why and how did you read at that time? What help did you get when you read? If you didn't read anything before you went to school, what do you think was the reason?

--What did you usually do in Chinese class at school? How did you learn the texts in class? Did you read anything except Chinese textbooks? If yes, what, why, and how did you read? Did you have any difficulties in doing so? Do you think there is any connection between reading in class and outside school? Why do think there's such connection or there is not such connection? Did you experience any change in your reading practice compared with before going to school? Why or why didn't you change?

--How did you learn English at school? Did you read anything in English except textbooks? If yes, what, why and how did you read? What difficulties did you have in reading English? Do you think there is any connection between reading in class and outside school? Why do think there's such connection or there is not such connection? Did your reading practices both in L1 and L2 change during your middle school years (from the age of 12 to 18)? Why or why didn't you change?

--What were English classes like at university? Did you read anything in English at that time? What, why and how did you read? Did you have any difficulties? Did you read anything in Chinese except textbooks? What, why and how did you read? Did you see any influence of your reading habits in Chinese on your reading in English? If yes, what is it? If no, why do you think there is no influence? Did your reading practices both in L1 and L2 change during your university years (from the age of 18 to 22)? Why or why didn't you change?

--What change in your reading practices did you experience after you arrived here? What caused that change? Are you able to cope with the change? What difficulties do you have in reading in English during your stay here? Are they similar to the difficulties you had before? If no, what is the difference and what do you think causes the difference?

--Finally, as this is the pilot study, I need to find out what the interviewee thinks of the questions they were asked. What questions are difficult to answer or embarrassing? How can the interview be conducted better?

## Appendix 26: Questions for the second interviews with students (pilot study)

Interviews at the second stage of the pilot study aim to elicit more specific details of the interviewees' reading practices in order to see possible differences in their reading practices in different sociocultural settings, and how their existing experience facilitates or hinders their coping with reading in current situations.

Questions:

Part one: details about what has been read in the past 24 hours.

- \* What have you read in the past 24 hours, including everything in English and Chinese (e.g. newspapers, magazines, websites, email, address book, notes, cooking instructions, books, journals, etc.)?
- \* Why, where, and how did you read them?
- \* What do you usually do after reading something (if there may be any following actions)?

Part two: everyday reading practices in China.

- \* Could you try to recall things you usually read on a working day/weekday in China?
- \* Why, where, and how did you read them?
- \* What do you usually do after reading something (if there may be any following actions)?
- \* Could you try to recall things you usually read on a weekend or holiday in China?
- \* Why, where, and how did you read them?
- \* What do you usually do after reading something (if there may be any following actions)?
- \* Do you sense any change in your reading practices here compared to those in China?
- \* Why is there such change, or why isn't there any change?  
(Alternatively, I can point out their changes and ask why)

Part three: academic reading practices here.

- \* Could you show me something you have read recently?



- \* Where and how did you get hold of it (e.g. library, websites, handouts. Why did you choose this particular one to read)?
- \* How long did it take for you to finish?
- \* Where did you read it?
- \* How did you read it (e.g. whether read on their own or with others as a group, how to take notes, how to mark the text, what language to use for taking notes or marking, how to use the notes, etc.)?
- \* Why did you read it?
- \* What did you do with it after reading it?
- \* What is difficult in it, and why is it difficult?
- \* What is easy in it, and why is it easy?
- \* What do you remember/learn from the text?
- \* Do you read in different ways for different academic purposes? How and why?

Part four: academic reading practices in China.

- \* What sort of things did you read for academic purposes in China?
- \* Could you recall one particular case of academic reading in China?
- \* What was the reading for?
- \* Where and how did you get hold of it (e.g. library, websites, handouts)? Why did you choose this particular one to read?
- \* How long did it take for you to finish?
- \* Where did you read it?
- \* How did you read it (e.g. whether read on your own or with others as a group, how to take notes, how to mark the text, how to use the notes, etc.)?
- \* What did you do with it after reading it?
- \* What was difficult in it, and why was it difficult?
- \* What was easy in it, and why was it easy?
- \* What did you remember/learn from the text?
- \* Did you read in different ways for different academic purposes? How and why?
- \* Do you sense any change in your academic reading practices here compared to those in China?
- \* Why is there such change, or why isn't there any change?